



Capacity
4.9t x 2.1m

Max Lifting
Height 16.5m

Working Radius 14.67m

Weight
9450-9630kg

CC985



CC985

The latest version CC985 crawler crane has many improved features, such as a new engine, new wider cab and an improved moment limiter. With a 16.5m working height, new 7" multi function monitor and a massive 2000kg pick and carry capacity, this crane offers improved features coupled with great lifting duties.

The optional 2-section Fly Jib increases maximum lifting height to 20.2m.

This model also includes an EU stage IIIB compliant engine to make it more environmentally friendly.

- 4.9 Ton Max Capacity
- 16.5m Max Working Height
20.2m with Optional Fly Jib Attachment
- 2000kg Pick & Carry Duty
- 7 inch Multi Monitor
- Powerful Two Speed Winch with Hydraulic Disc Brake
- 4 Fall / 2 Fall Hook Block
- Tilt Sensor/Alarm
- Rear View Camera
- Automatic Pentagonal 5-Section Boom
- Data Logger
- 2 Year Warranty

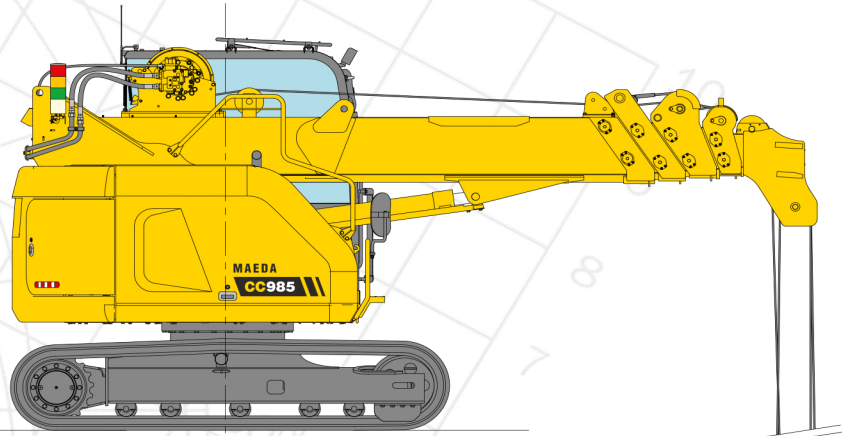

Working Range Chart (4falls)

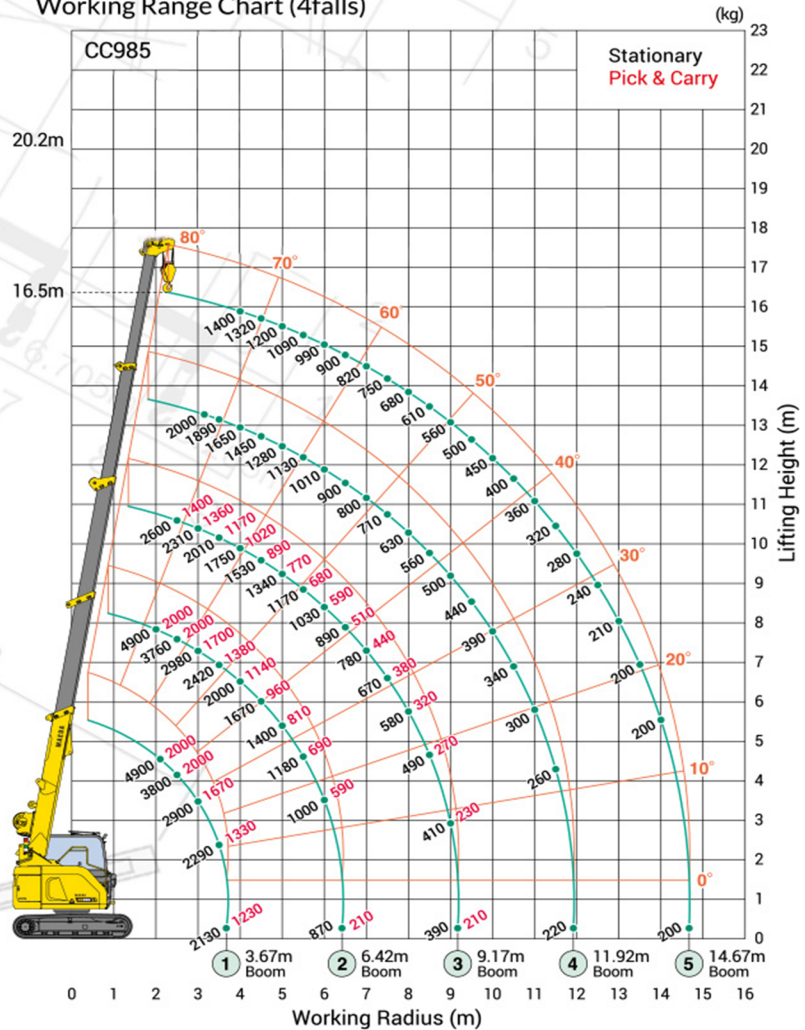

This working range chart shows total rated load including boom and jib deflection.



... consider the possibilities



Total rated load (4 falls)											
Working radius (m)	Total rated load (kg)										
	4.78m Boom		7.53m Boom		10.28m Boom		13.03m Boom		15.78m Boom		
	Stationary	Pick & Carry	Stationary	Pick & Carry	Stationary	Pick & Carry	Stationary	Pick & Carry	Stationary	Pick & Carry	
2.0	4900	2000	4900	2000	2600	1400	2000				
2.1	4900	2000	4630	2000	2600	1400	2000				
2.5	3800	2000	3760	2000	2600	1400	2000				
2.7	3310	1950	3410	1940	2520	1400	2000				
3.0	2900	1670	2980	1700	2310	1360	2000				
3.15	2640	1550	2800	1590	2220	1300	2000				
3.5	2290	1330	2420	1380	2010	1170	1890				
3.67	2130	1230	2270	1290	1920	1120	1800				
4.0			2000	1140	1750	1020	1650				
4.5			1670	960	1530	890	1450				
5.0			1400	810	1340	770	1280				
5.5			1180	690	1170	680	1130				
6.0			1000	590	1030	590	1010				
6.42			870	510	910	520	910				
6.5					890	510	900				
7.0					780	440	800				
7.5					670	380	710				
8.0					580	320	630				
8.5					490	270	560				
9.0					410	230	500				
9.17					390	210	480				
9.5							440				
10.0							390				
10.5							340				
11.0							300				
11.5							260				
11.92							220				
12.0											
12.5											
13.0											
13.5											
14.0											
14.67											



Dimensions

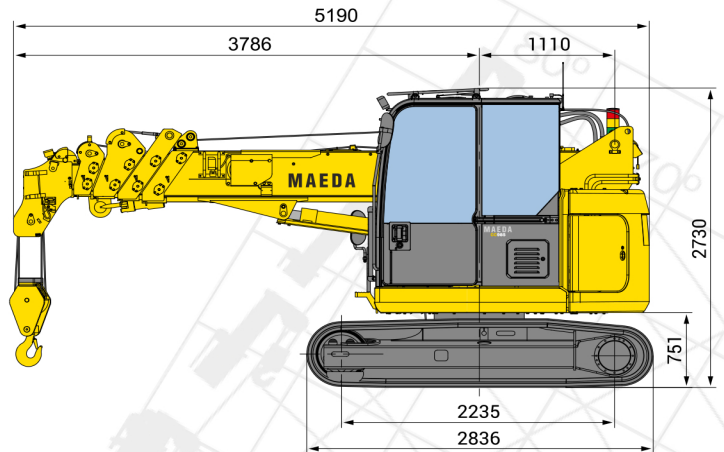
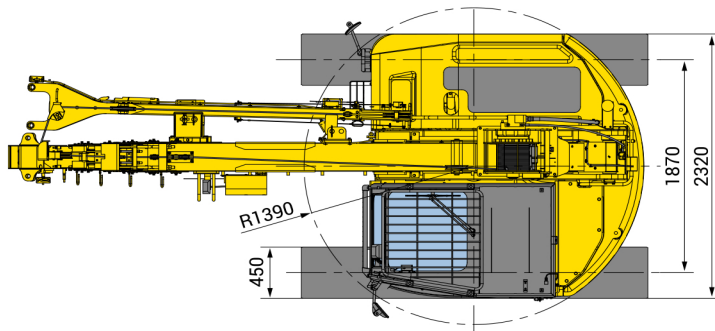



CC985

Specifications

Capacity Pick and carry	Maximum	4.9t x 2.1m 2000kg
Working radius	Maximum	14.67 m x 200kg
Lifting height	Maximum	16.5m x 1400kg (20.2m x 430kg with Fly Jib)
Dimensions	CC985	5190mm x 2320mm x 2730mm
Weight	CC985 Hook block weight	9450kg (9630kg with Fly Jib) 90kg
Hook speed	Maximum	44m/min (4 layers, 4 falls)
Single line speed	Low speed High speed	120 m/min 176 m/min
Hoist rope	Type	IWRC 6 x Fi (29) Ø 10 mm x 115m
Telescopic system	Boom length Telescoping speed Boom type	4.78m – 15.78m 11m / 24sec. Fully automatic 5 section pentagonal telescopic boom
Boom hoist system	Hoist angle / speed	-2~80deg /13sec
Slew system	Slew angle / speed	360° continuous / 1.9 rpm
Drive	Type Traction speed Gradability Ground length x width Ground pressure	Independent steering controls, hydraulic piston motor with built-in automatic brake, planet reduction gears, sprocket and crawler Low 0-1.9 km/h High 0-3.2 km/h 20° 2235mm x 450mm 0.47 kgf / cm ² (0.48 kgf / cm ² with Fly Jib)
Engine	Model Type Rated output Fuel tank capacity	ISUZU 4LE2XDPC 4 cylinder diesel, water cooled, direct injection 40.3kW / 2000 rpm Diesel / 140 L
Standard equipment	Moment limiter, steel tracks, overwind protection, load indicator, hydraulic safety valves, wire rope latch, level, EMO switch, LED working status lamp, safety lock lever, working light, hour meter, tilt alarm, 4-fall / 2-fall hook block, rear view camera, data logger.	

