



Volvo Construction Equipment

EWRI50E

Volvo Excavators 15.4-17.9 t 105 kW



SHORT SWING PERFORMANCE

Swing into action, and take on the jobs that a conventional excavator can't, with improved lifting capacity, so you won't have to compromise on reach, lifting or digging performance. The market leading tail swing of the EWR150E, at 1 720 mm, and the short tail swing of the EWR170E, at 1 790 mm make for efficient and safe work in confined spaces.



*The short swing radius is clearly a major benefit, as it enables us to work in a tight residential environment without obstructing traffic.
On-site manager Thorsten Bargatsky, Gebr. Kickartz GmbH, Germany*



Volvo EWR150E in detail

Engine

Volvo Construction Equipment is ready to comply with the tough new EU Stage IV legislation for off-road vehicles with the introduction of a cascade of innovations in its new generation engines with Volvo Advanced combustion technology (V-ACT).
Volvo machines are equipped with in-line turbo charged diesel engine with high pressure unit injector system. The engine features an externally cooled exhaust gas re-circulation (E-EGR), a Diesel Particulate Filter (DPF) and a Selective Catalytic Reduction (SCR) with AdBlue.

Engine	Volvo	D4J
Max. power at	r/min	2 000
Net (ISO9249/SAEJ1349)	kW	102
	hp	139
Gross (ISO 14396/SAE J1995)	kW	105
	hp	143
Max. torque	Nm	605
at engine speed	r/min	1 500
No. of cylinders		4
Displacement	l	4.04
Bore	mm	101
Stroke	mm	126

Electrical system

High-capacity electrical system that is well protected. Waterproof double-lock harness plugs are used to secure corrosion-free connections. The main relays and solenoid valves are shielded to prevent damage. The master switch is standard.

Voltage	V	24
Batteries	V	2 x 12
Battery capacity	Ah	2 x 100
Alternator	V/Ah	24/120
Alternator rating	W	3 360

Undercarriage

Drive train: A variable axle piston motor in combination with a power shift gearbox supplies 3 speeds. The gearbox distributes the energy via propeller shafts to the axles.
2 different undercarriages : a) Welded radial blade only with EW140 drive train. b) Bolted undercarriage with parallel blade with EW160 drivetrain and the option to add outriggers.
Wheels: Alternative single and twin wheels available.
Front axle: Robust excavator axle with automatic or operator controlled front axle oscillation lock.

Oscillating	± °	9
with mudguards	± °	6
Twin wheels	type	10/11-20
Tractive force (net)	kN	88 / 111
Travel speed, on road	km/h	20 / 30 / 35
Travel speed, off road	km/h	5.0 / 8.5
Travel speed, creep	km/h	3
Min. turning radius	m	7.3

Swing system

The superstructure is slewed by the means of a radial piston motor without reduction gear.
Automatic slew holding brake and anti-rebound valve are standard.

Max. slew speed	r/min	9
-----------------	-------	---

Brake system

Service brakes: servo-hydraulically manoeuvred self-adjusting wet multidiscs with two separate brake circuits.
Parking brake: negative wet disc in gear housing, spring applied and pressure released.
Digging brake: service brake with mechanical lock system.
Security system: The 2-circuit travel brakes are supplied with two accumulators in the event of failure in the service brake system.

Sound Level

In cab, acc. to ISO 6396		
LpA	dB(A)	71
External, acc. to ISO 6395 and Directive 2000/14/EC		
LwA	dB(A)	100

Hydraulic system

Load sensing hydraulic system with pressure compensated valves. Load independence of movements. Flow sharing feature, combined with a high flow pump (power regulation). The system gives superior manoeuvrability and fast movements, for optimal working result and economy.
The following working modes are included in the system:
Parking mode (P): Parking position for optimal safety.
Travel mode (T): Engine speed is controlled by travel pedal stroke for low fuel consumption and noise.
Working mode (W): Full working flow with adjustable engine rpm for normal working and best speed utilisation.
Customer mode (C): Operator can set proper oil flow in accordance with job conditions.
Power Boost: All digging and lifting forces are increased.

Main pump (type low noise axial piston pump)

Max. flow	l/min	275
-----------	-------	-----

Brake + steering pump (type low noise gear pump)

Max. flow	l/min	50
-----------	-------	----

Attachment circuit

Max. flow	l/min	220
-----------	-------	-----

Relief valve setting pressure

Implement	MPa	32.5 / 36
Travel system	MPa	36
Pilot system	MPa	3.5

Total Machine Weights

Machine with 4.5 m monoblock boom, 2.45 m dipper arm, quickfit S6, 410 kg / 580 l bucket.		
With welded radial dozer blade front and outriggers rear	kg	16 500
With welded radial dozer blade rear only	kg	15 400
With bolted dozer blade front and outriggers rear	kg	17 400
With bolted dozer blade rear only	kg	16 300
Machine with 4.7m 2-piece boom, 2.45 m dipper arm, quickfit S6, 410 kg / 580 l bucket.		
With welded radial dozer blade front and outriggers rear	kg	17 000
With welded radial dozer blade rear only	kg	15 900
With bolted dozer blade front and outriggers rear	kg	17 900
With bolted dozer blade rear only	kg	16 800

Service Refill

Fuel tank	l	200
DEF/AdBlue® tank	l	25
Hydraulic system, total	l	230
Hydraulic tank	l	104
Engine oil	l	16
Engine coolant	l	32
Transmission	l	2.5

Axle differential:

Front axle	l	9.5
Rear axle	l	12.5
Final drive	l	4 x 2.5

Cab

New design Volvo Care Cab with operator protective structure, large and roomy interior. One way travel pedal with rocker switch control (F-N-R) on the right joystick. One-touch release for digging brake pedal.
Audio system with remote control and Bluetooth system for hands free phoning. Independently adjustable joystick consoles.
Excellent all-round visibility provided by maximized cab class, transparent roof hatch, 2-piece sliding door window and long stroke, easy to adjust and new narrow steering column. The liftable front windshield can easily be stored in the inside roof space and clipped in position. The removable lower front glass can be stored in the side door pocket. Interior lighting consists of one reading light and one light with timer.
The pressurized and filtered cab air is supplied by a 14-vent climate-control providing fast defrosting and high cooling and heating performance. Viscous/spring mounted suspension cushions protect the operator from vibrations.
Deluxe air-suspension seat with adjustable seat suspension, height, tilt, recline and forward-backward settings.(option)
Adjustable, easy to read 8.3" LCD color monitor provides real time information of machine functions and important diagnostic information and is switchable to rear view camera monitor(standard) / side view camera (option). A new multi function button on left hand joystick with programmable function to improve the operator comfort.
Refrigerant of the type R134a is used when this machine is equipped with air conditioning. Contains fluorinated greenhouse gas R134a, Global Warming Potential 1.430 t CO2-eq.

Specifications

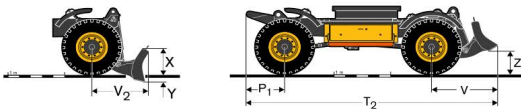
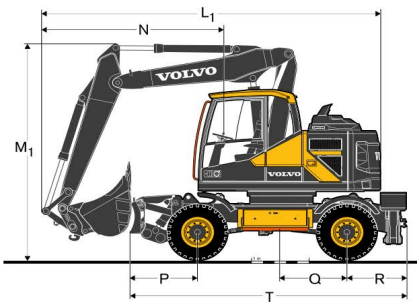
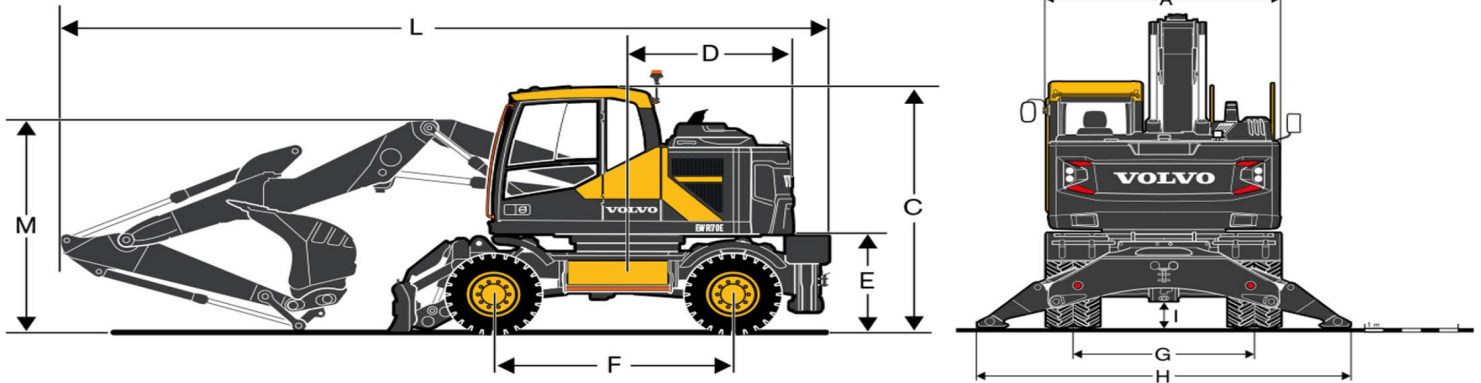

DIMENSIONS		EWR150E	
Description	Unit	2-piece boom	
	m	4.7	
A	Overall width of superstructure	mm	2 520
B	Overall width	mm	2 540
C	Overall height of cab	mm	3 150
D	Tail slew radius	mm	1 720
E	Counterweight clearance	mm	1 260
F	Wheel base	mm	2 600
G	Tread	mm	1 940
H	Outrigger width (front or rear)	mm	3 990
I	Min. ground clearance	mm	340
Description	Unit	2-piece boom	
	m	4.7	
Description	Unit	Arm	
	m	2.6	
L	Overall length	mm	7 790
M	Overall height of boom	mm	3 040
L1	Overall length	mm	6 610
M1	Overall height of boom	mm	3 970
N	Front overhang	mm	3 190

** without bucket

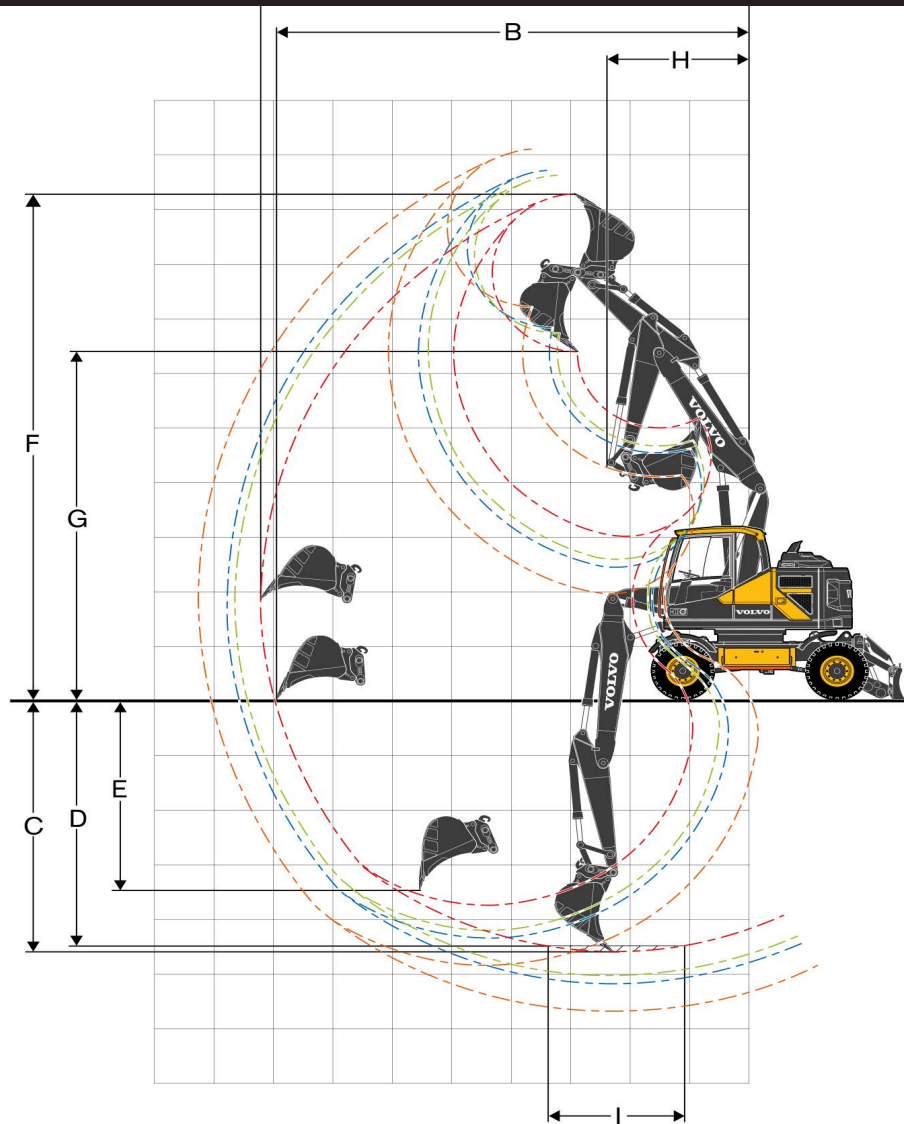

WORKING RANGES WITH DIRECT FIT BUCKET

		4.7 m 2-piece boom EWR150E	
		Unit	Arm
		m	2.6
A	Max. digging reach	mm	8 810
B	Max. digging reach on ground	mm	8 620
C	Max. digging depth	mm	5 240
D	Max. digging depth (l = 2 440 mm level)	mm	5 140
E	Max. vertical wall digging depth	mm	4 100
F	Max. cutting height	mm	9 670
G	Max. dumping height	mm	6 780
H	Min. front slew radius	mm	2 600

Note: 1. Bucket size based on SAE-J296, heaped material with a 1:1 angle of repose. | 2. "Max permitted sizes" are for reference only and are not necessarily available from the factory. | 3. "Max permitted sizes" are for heavy counterweight.



LIFTING CAPACITY EWR150E - Welded undercarriage

At the arm end, without bucket and quick fit. For lifting capacity including bucket/quick fit, simply subtract actual weight of those parts from the following values.
With heavy counterweight. Unit: 1 000kg

	Lifting point	Reach from machine centre (u = support up/d = support down)																				
		1.5 m				3.0 m				4.5 m				6.0 m				Max.				
		Across UC		Along UC		Across UC		Along UC		Across UC		Along UC		Across UC		Along UC		Across UC		Along UC		Max.
		u	d	u	d	u	d	u	d	u	d	u	d	u	d	u	d	u	d	u	d	m
4.7 m 2 piece boom 2.6 m dipper arm Front radial blade Rear outriggers	7.5	-	-	-	-	-	-	-	-	3.0*	3.0*	3.0*	3.0*	-	-	-	-	3.0*	3.0*	3.0*	3.0*	4.5
	6	-	-	-	-	-	-	-	-	3.5*	3.5*	3.5*	3.5*	-	-	-	-	2.4	2.5*	2.5*	2.5*	6.0
	4.5	-	-	-	-	-	-	-	-	3.8	3.9*	3.9*	3.9*	2.4	3.6*	3.6*	3.6*	1.9	2.4*	2.4*	2.4*	6.8
	3	-	-	-	-	6.5	7.2*	7.2*	7.2*	3.5	4.9*	4.9*	4.9*	2.3	4.0	3.8	4.0*	1.7	2.4*	2.4*	2.4*	7.3
	1.5	-	-	-	-	-	-	-	-	3.3	5.8*	5.6	5.8*	2.2	3.8	3.6	4.4*	1.6	2.5*	2.5*	2.5*	7.4
	0	-	-	-	-	5.4	5.4*	5.4*	5.4*	3.1	5.7	5.4	6.3*	2.1	3.7	3.5	4.6*	1.6	2.8*	2.7	2.8*	7.1
	-1.5	-	-	-	-	5.4	8.9*	8.9*	8.9*	3.0	5.6	5.3	6.2*	2.0	3.7	3.5	4.5*	1.8	3.3	3.1	3.4*	6.6
4.7 m 2 piece boom 2.6 m dipper arm Radial Blade Rear	7.5	-	-	-	-	-	-	-	-	3.1*	3.0*	3.1*	3.0*	-	-	-	-	3.1*	3.0*	3.1*	3.0*	4.5
	6	-	-	-	-	-	-	-	-	3.5*	3.5*	3.5*	3.5*	-	-	-	-	2.3	2.5*	2.6*	2.5*	6.0
	4.5	-	-	-	-	-	-	-	-	3.6	3.9*	3.9*	3.9*	2.3	2.6	3.6*	3.6*	1.8	2.1	2.4*	2.4*	6.8
	3	-	-	-	-	6.1	7.2*	7.1*	7.2*	3.3	3.9	4.8*	4.9*	2.2	2.5	3.6	4.0*	1.6	1.8	2.4*	2.4*	7.3
	1.5	-	-	-	-	-	-	-	-	3.0	3.6	5.4	5.8*	2.0	2.4	3.5	4.4*	1.5	1.7	2.5*	2.5*	7.4
	0	-	-	-	-	5.1	5.4*	5.5*	5.4*	2.9	3.4	5.2	6.3*	1.9	2.3	3.4	4.6*	1.5	1.8	2.6	2.8*	7.1
	-1.5	-	-	-	-	5.1	6.1	9.0*	8.9*	2.8	3.3	5.1	6.2*	1.9	2.2	3.3	4.5*	1.7	2.0	3.0	3.4*	6.6

Notes: 1. Working pressure with Power Boost = 37.5 MPa. 2. The above values are in compliance with ISO standard 10 567. They do not exceed 87 % of hydraulic lifting capacity or 75 % of tipping load, with the machine on firm, level ground. 3. Load capacities marked with an asterisk (*) are limited by machine's hydraulic lifting capacity rather than tipping load.



Equipment

STANDARD EQUIPMENT

EWR150E

Engine

Turbocharged, 4 stroke Volvo diesel engine with water cooling, direct injection and charged air cooler that meets EU Stage IV emission requirements	•
Intake air pre-heater	•
ECO- Modus	•
Fuel filter and water separator	•
Fuel filler pump: 50 l/min with automatic shut-off	•
Aluminium core radiator	•

Electric / Electronic control system

Contronics-computerized monitoring and diagnostic system	•
Adjustable automatic idling system	•
One-touch power boost	•
Adjustable monitor	•
Safety stop/start function and master electrical disconnect switch	•
2 Frame mounted halogen lamps	•
Alternator, 120 A	•
Batteries, 2 x 12 V/140 Ah	•
Start motor, 24 V/5.5 kW	•
CareTrack via GSM or satellite	•
Rear view camera	•
Side view camera left hand side	•

Superstructure

LED Rear lights	•
Service walkway with anti-slip grating	•
Centralised lubricating point for slew bearing and boom	•

Undercarriage

3 speeds: creep / offroad / road speed up to 35 km/h	•
Oscillating front axle $\pm 9^\circ$ with out mudguards/ 6° with mudguards	•
2-circuit travel brakes	•
Maintenance-free propeller shafts	•

Hydraulic system

Load sensing hydraulic system	•
Pressure relief system (servo accumulator)	•
Proportional controlled visco-clutch cooling fan	•
Hose rupture valve for boom and arm	•
Hydraulic long life oil ISO VG 46	•

Cab and interior

Volvo Care Cab with fixed roof hatch /ROPS	•
Cup holder	•
Door locks	•
Safety glass, light tinted	•
Floor mat	•
Horn	•
Large storage area	•
Pull-up type front window	•
Removable lower windshield	•
Retractable seat belt	•
Windshield wiper with washer and intermittent feature	•
Heater & air-conditioner, automatic	•
Hydraulic dampening cab mounts	•
Adjustable operator seat and joystick control console	•
Adjustable steering column	•
Hydraulic safety lock lever	•
Control joysticks, Proportional or L8 proportional	•
Bluetooth radio with USB port	•
Sun shield, front, roof & rear	•
Master ignition key	•
Multi function switch on LH Joystick	•

Digging Equipment

Attachment points for extra hydraulics	•
Centralised lubrication point for arm and bucket	•