

KLUBB

KLUBB KAT 42 User Manual



KLUBB
12 avenue James de Rothschild
77164 FERRIERES-EN-BRIE-FR
Phone: +33 1 60 31 28 18
Email: contact@klubb.com

Taking choice, support and quality to new heights





TABLE OF CONTENTS

CHAPTER 1: INTRODUCTORY INFORMATION	2
SECTION 1.1: ABOUT THIS MANUAL	3
SECTION 1.2: SAMPLE CERTIFICATES	4
SECTION 1.3: IDENTIFYING THE MACHINE	5
CHAPTER 2: SAFETY INFORMATION	6
SECTION 2.1: GENERAL INFORMATION	8
SECTION 2.2: CONDITIONS FOR OPERATION	11
SECTION 2.3: RECOMMENDATIONS FOR USE	16
SECTION 2.4: OPERATING PERSONNEL	18
SECTION 2.5: SAFETY DEVICES	25
SECTION 2.6: SAFETY DECALS	21
CHAPTER 3: TECHNICAL INFORMATION	24
SECTION 3.1: MACHINE OVERVIEW	25
SECTION 3.2: MACHINE OVERVIEW: HYDRAULICS	27
SECTION 3.3: AIR SUSPENSION	29
CHAPTER 4: OPERATION	32
SECTION 4.1: PREPARING TO OPERATE THE MACHINE	33
SECTION 4.2: CAB CONTROLS	34
SECTION 4.3: MAIN CONTROL BOX	35
SECTION 4.4: DECK CONTROLS	36
SECTION 4.5: BASKET CONTROLS	37
SECTION 4.6: STABILISING THE PLATFORM	39
SECTION 4.7: RAISING THE PLATFORM	40
SECTION 4.8: CLOSING THE PLATFORM	41
SECTION 4.9: EMERGENCY PROCEDURES	42
CHAPTER 5: MAINTENANCE	44
SECTION 5.1: INTRODUCTION	45
SECTION 5.2: SAFETY NOTICES	46
SECTION 5.3: ROUTINE CHECKS	47
SECTION 5.4: REGULAR MAINTENANCE CHECKS	50





CHAPTER 1

INTRODUCTORY INFORMATION





1.1 ABOUT THIS MANUAL

Please ensure that you have read and understood the information outlined in this manual prior to operating the machine. All of the instructions in this manual are based on the use of the machine when it is working correctly, without any modifications to the original model. Any alterations are strictly forbidden without prior authorisation from KLUBB.

This manual MUST be kept in the vehicle cab at all times

- The instructions, drawings and documents in this manual, which contain confidential technical information, are the property of the manufacturer and may not be reproduced in any way, either entirely or partially.
- In terms of product development and use of devices and instruments, the manufacturer has always aimed to incorporate the most modern and advanced technology, while also meeting customer's needs and offering bespoke designs. This could result in differences between the instructions in the manual and the device itself.
- No legal action may be taken by the operator, user company, or service centres on the basis of any instructions, illustrations, or descriptions contained in this instruction manual.
- The manual must be kept for future reference until the machine is scrapped.
- If the machine is sold on or hired out, the seller or hirer must pass on the manual to the new owner or user.
- The information in the manual is arranged into topic-based chapters.
- The table of contents allows quick and easy reference to the various topics.
- The instruction manual must be made available to operators.
- This manual assumes that the machine will be used in compliance with applicable work safety regulations in the country of use.
- If the manual is lost or damaged, a copy may be obtained from the dealer by specifying the model data, serial number and year of construction.
- This manual shall not replace any kind of vocational training.
- Use of the manual for any purposes other than machine use and maintenance is prohibited.
- If any unauthorised modifications are made to the machine, the manufacturer is not responsible for altering the manual to suit these alterations.
- For repair, service and warranty assistance, please call Nacelle Assistance and Service +33 1 64 68 39 43
- To get the best out of your machine, always use spare parts that are recommended by the manufacturer. Again, please contact KLUBB Head Office for more information.

1.2 SAMPLE CERTIFICATES



Manuel utilisateur - KAT42

I. Déclaration de conformité

Ci-dessous, le spécimen de la déclaration de conformité CE :

Déclaration CE de Conformité relative aux machines	
Fabricant	
Société :	KLUBB
Adresse :	12, av. James de Rothschild 77164 Ferrières en Brie, France
Téléphone :	+33 (0)1 60 95 12 47
Fax :	+33 (0)1 60 05 68 38
Identification Produit	
Description :	Plates-Formes Elévatrices Mobiles de Personnel (PEMP) de type 1 B
Type :	KLUBB KAT42
No série PEMP :	
Véhicule :	NISSAN Navara
No série Véhicule :	
Dossier Technique	
Le dossier technique a été constitué sous la responsabilité de M. Rey, Directeur des Opérations. Il a été autorisé d'effectuer cette tâche par le fabricant.	
Adresse :	KLUBB - 12, av. James de Rothschild 77164 Ferrières en Brie, France
Conformité Ce produit a été conçu, fabriqué et validé conformément à la <i>directive machines</i> du 17 mai 2006 (2006/42/CE), la directive relative à la <i>compatibilité électromagnétique</i> du 15 décembre 2004 (2004/108/CE) et la directive relative à l' <i>émission du bruit dans l'environnement par des équipements pour une utilisation en plein air</i> du 8 mai 2000 (2000/14/CE).	
L'assemblage de la structure haute de la PEMP et l'installation sur le véhicule ont été effectués conformément aux méthodes définies par le fabricant, et aux spécifications et au cahier de charge définies par le constructeur du véhicule.	
Le résultat de tous les contrôles de fabrication, les essais et les preuves de qualification sont enregistrés conformément aux processus qualité du fabricant.	
Aucune modification des boîtiers de commande, des éléments de sécurité ou options ayant un rapport avec la sécurité de la nacelle n'est autorisée sans l'accord explicite de la société KLUBB.	
Examen CE de type	
Cette réception par type a été approuvée par l'organisme notifié suivant :	
Nom :	APAVE Parisienne SAS
No d'identification :	0060
Adresse :	17 rue Salneuve – 75854 Paris CEDEX
No Attestation CE Type :	0060/ 5536 / 760 / 11/15 / 0001
Normes Harmonisées La conception, la fabrication, l'installation, la protection et essais du PEMP ont été réalisés conformément aux normes européennes, internationales et nationales. Les plus importantes sont mentionnées dans la liste ci-dessous :	
EN 280	Plates-formes élévatrices mobiles de personnel – Calculs de conception – Critères de stabilité – Construction – Sécurité – Examens et essais
EN 349	Sécurité des machines – Ecartement minimaux pour prévenir les risques d'écrasement de parties du corps humain
EN 13849-1	Sécurité des machines - Parties des systèmes de commande relatives à la sécurité - Partie 1 : principes généraux de conception
EN 13849-2	Sécurité des machines - Parties des systèmes de commande relatives à la sécurité - Partie 2 : validation
EN 60204-1	Sécurité des machines – Equipement électrique des machines – Partie 1 : règles générales
ISO 20381	Plates-formes élévatrices mobiles de personnel – Symboles pour les commandes de l'opérateur et autres indicateurs
Lieu de déclaration :	Ferrières en Brie, France
Date :	09/11/2016



1.3 IDENTIFYING THE MACHINE

There are machine identification plates fixed onto your machine: The identification plates are stamped with the following details which must be quoted to the manufacturer or dealer in any dealings with them. It is strictly prohibited to alter the information on this plate.

KLUBB		PLAQUE CONSTRUCTEUR BUILDER'S PLATE		CE	
Modèle de la nacelle / Designation - Lift model KLUBB /		Charge utile max en nacelle (personnes comprises) Max payload inside the lift (people included)		Nb de personne Nb of person	
Numero de serie - Serial number		Hauteur max plancher - Maximum floor height		<input type="text"/> kg <input type="text"/> pers	
Date de construction (MM/AAAA) - Date of building (MM/YYYY)		Déplacement basculier - Maximum basket edge offset		<input type="text"/> m	
Puissance nominale - Nominal power		Inclinaison max du véhicule (Longitudinale / Transversale) Vehicle maximum tilting (Longitudinal / Transversal)		<input type="text"/> W <input type="text"/> % / %	
Masse du véhicule - Total weight of equipment		Force horizontale max - Maximum horizontal strength		<input type="text"/> kg <input type="text"/> N	
KLUBB 12, avenue Jacques de Rothschild 77164 Fontaines-en-Brie		Vitesse max du vent - Maximum wind speed		<input type="text"/> m/s	

CHAPTER 2 SAFETY INFORMATION





2.1 GENERAL INFORMATION

ILLUSTRATIONS

 For ease of understanding, some illustrations in this manual will show the machine with the guards, covers or panels removed. Never use the machine without covers or guards.

The drawings of the machine in this manual are provided for illustrative purposes only. These may not be accurate to your particular design.

TECHNICAL ASSISTANCE

The mobile elevated work platform is covered by warranty, as stated in the general conditions of sale. During and after the warranty period, the KLUBB Service Department is at your disposal to provide any services you may need.

Please note that any alterations made by the user, without the manufacturer's express written permission, will render the warranty null and void and release the manufacturer from any liability for damage caused by a defective product. This is particularly true when such changes concern a safety device, reducing its effectiveness. The same considerations apply if non-original spare parts are used or any parts other than those specified by the manufacturer. For these reasons, we recommend you always contact your dealer.

DISCLAIMER NOTICE

The manufacturer cannot be held responsible for the following:

- Improper use of the machine;
- Unauthorised alterations or work on the machine;
- Failure to follow the highway code and regulations concerning machine transportation from one work site to another;
- Total or partial failure to comply with instructions herein;
- Lack of maintenance;
- Use of non-original spare parts or parts not designed specifically for the model concerned;
- Exceptional environmental conditions.

MOVEMENT

Be aware of obstacles e.g. bridges

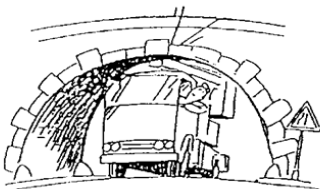

VEHICLE LEVELLING

Ensure the vehicle is on level ground prior to operation



STABILISATION

Check ground stability prior to using the machine



Do not exceed the maximum inclination

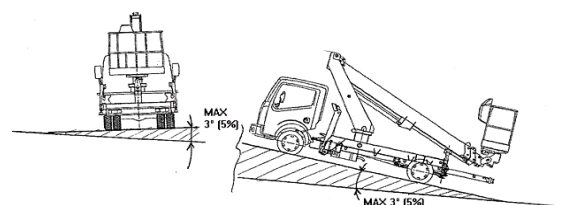

2.1 GENERAL INFORMATION

WORKING AREA

Place barriers around working area. When working on the road, cone off and sign post the area as per highway regulations. **Do not extend the boom structure into lanes open to traffic.**

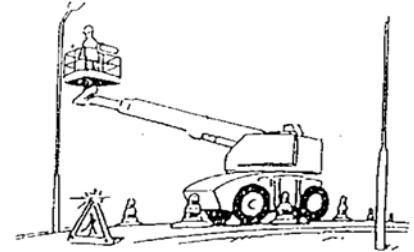

EMERGENCY STOP

If there is an emergency or any danger. Stop the machine. **Ensure that the dangerous situation is over prior to operating the machine again.**

OBSTACLES AND ELECTRIC LINES

Make sure that there are no electric lines within the safe distance guidelines.

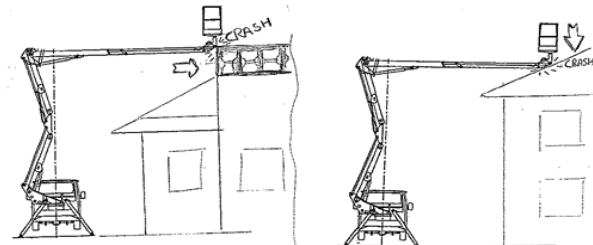

PUSHING OR LOWERING AGAINST OBSTACLES

Extending the boom against obstacles (opening/closing and/or lifting/lowering/rotating) may create structural damage to the machine and have a serious risk of tipping over the platform. Before and during any movements, always verify visually any obstructions are clear of the machine structure in all directions (with particular attention to the hidden parts, such as the lower part of the basket).

WIND

It is recommended to always use safety harnesses. Do not operate platform if wind is exceeding 12.5 m/s. Do not take equipment in the basket that has a large surface area as this will increase wind load. **Always take into account the wind conditions as this could cause the MEWP to lose stability and cause death or serious injury.**

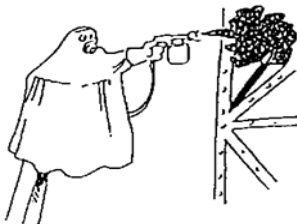
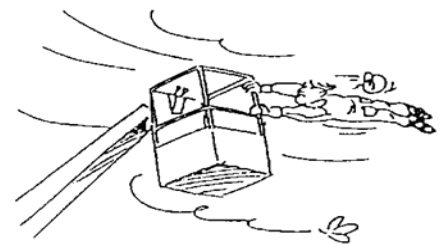

PROTECTION

When performing special work, always safeguard yourself with the appropriate PPE as well as safeguarding the machine.

2.1 GENERAL INFORMATION



IN THE BASKET

Never use ladders, boards or other objects to reach out of the basket.
It is forbidden to exit the basket when it is raised.

Never exceed the loading capacity allowed in the basket as this could tip the machine over or damage the MEWP. In turn this could cause death or serious injury.

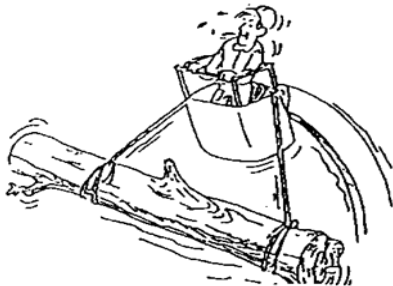

LIFTING

Never use the platform as a lifting device, not even for small weights as this could tip the machine over or damage the MEWP. In turn this could cause death or serious injury.

SAFETY HARNESS AND HELMETS

It is recommended to always use safety harnesses. Helmets should be worn if working near overhead obstacles. Do not fasten harnesses to structures outside the basket.

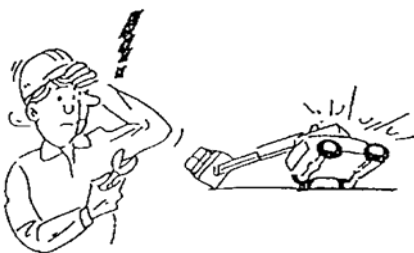

REPAIRS AND MODIFICATIONS

Do not carry out any repair or modifications unless it is through an authorised repair centre.

ATTENTION! LOADING AT HEIGHT

Do not load the basket while the boom is extended as this could tip the machine over. In turn this could cause death or serious injury.

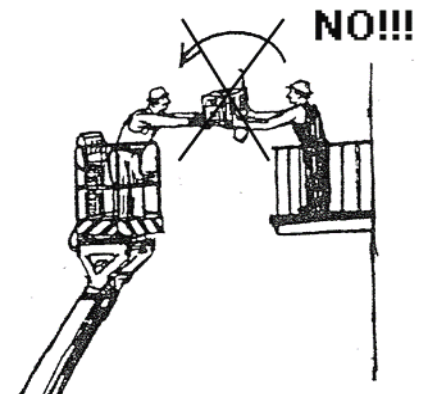

2.2 CONDITIONS FOR OPERATION

INTENDED USE

The machine is designed to move people to overhead positions in order to perform operations from inside the work platform.

Use of the machine is permitted if the instructions shown in this manual are complied with.

Any other use than that specified, or not included or inferable from this manual, should be considered mishandling and therefore **is not permitted**.

UNAUTHORISED USE



Use of the machine in any other installation conditions than the original configuration supplied by the manufacturer is prohibited, as is use of the machine in any way other than that stated herein.



Use is prohibited in the event of functional anomalies and non-compliances with the use and safety requirements stated in this manual. In the event, request and wait for the authorised personnel.

Any uses not outlined by regulation UNI EN 280 fall under the direct responsibility of the user, who is required to comply with the legal provisions in force regarding health and safety in the workplace.

NOTE!! The machine cannot be put back into use after undergoing structural alterations or additions of other components which do not come under routine and special maintenance unless a new declaration of conformity is issued.

TEMPERATURE

The machine operates properly in the following environmental conditions:

- Minimum temperature: - 10°C
- Maximum temperature: + 40°C
- Humidity: 80% at 40°C

If used in a cold climate, start the machine and allow the oil, equipment, and systems to warm up.

Upon first use, take special care during manoeuvres.

Constantly check that the batteries are charged.

Minimum starting temperature: - 20°C

For use in conditions other than those specified above, always contact the manufacturer.

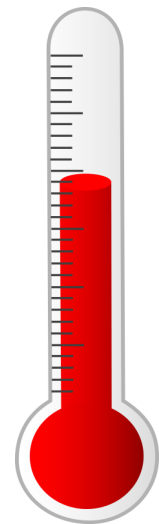

2.2 CONDITIONS FOR OPERATION

WIND SPEED

To gauge the wind speed, use an anemometer and refer to the chart below for guidance only.

Wind Force		Wind Speed		Effect of wind inland
Beaufort Number	Name	m/s	km/h	
0	calm	<0.3	1	Calm, smoke moves directly upwards
1	light air	0.3 - 1.5	1 - 5	Wind direction only indicated by the movement of smoke, not by a weather cock
2	light breeze	1.6 - 3.3	6 - 11	The wind can be felt against your face, leaves rustle, weathercocks move
3	gentle breeze	3.4 - 5.4	12 - 19	Leaves and branches move, the wind unfolds wind sleeves
4	moderate breeze	5.5 - 7.9	20 - 28	The wind picks up loose paper and cardboard, moves branches and thin poles
5	fresh breeze	8.0 - 10.7	29 - 38	Small hardwoods begin to wave, wave foam appears on lakes
⚠ 6	strong breeze	10.8 - 13.8	39 - 49	Poles move violently, telephone cables whistle, it is difficult to use an umbrella
⚠ 7	moderate gale (or near gale)	13.9 - 17.1	50 - 61	All the trees move, it is slightly difficult to move against the wind
⚠ 8	fresh gale (or gale)	17.2 - 20.7	62 - 74	Branches break off trees, it is considerably difficult to walk outside
⚠ 9	strong gale	20.8 - 24.4	75 - 88	Slight damage to houses (chimney tops and roof tiles are swept off)
⚠ 10	whole gale (or storm)	24.5 - 28.4	89 - 102	Trees are uprooted, considerable damage to houses

STABILITY

Use of the machine is only permitted when the vehicle is correctly stabilised and levelled.

There is a spirit level in the stabilisation controls area.

- Air bubble in the middle > the vehicle is horizontal
- Air bubble in between the two circles > vehicle tilted by between 0° and 5°

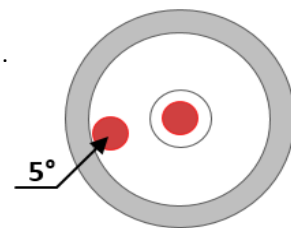

GROUND CONDITIONS

Ensuring ideal ground conditions when the MEWP is resting on the ground is crucial for the machine's stability. Steep slopes may yield under the weight of the outriggers or the wheels, in which case the machine may end up in an unstable position with a risk of overturning. Therefore before moving, using or positioning a MEWP, it is essential to assess the type of ground (its properties) and the gradient of the area where the machine will be standing. If you are even the slightest bit concerned that the ground could give way, check the level of the machine regularly and adjust the outriggers, support plates and ground shoring.

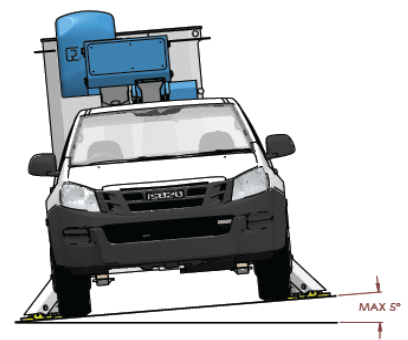
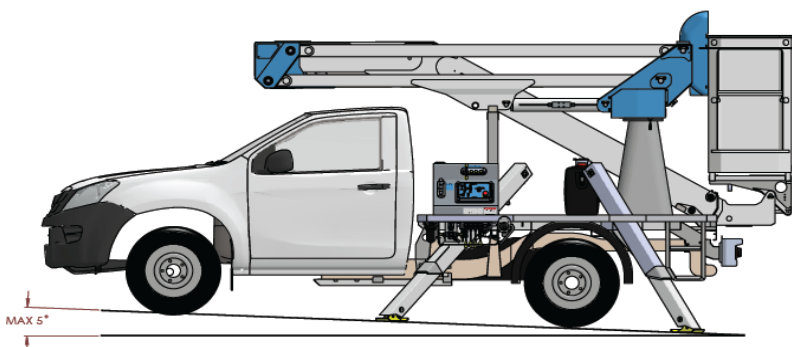

2.2 CONDITIONS FOR OPERATION

ASSESSMENT OF THE GROUND

Analysis of the ground can consist of a visual inspection of the surface or a detailed geotechnical survey.

Nevertheless, it is essential that the assessment be carried out by personnel with enough expertise and experience to be aware when advice must be sought from someone more skilled.

Assessing the load capacity of the underlying ground is the primary task of a civil engineer.

1) Loose ground

All forms of loose ground, including just laid surfacing (gravel, sand, mud, etc.) must be avoided.

2) Non-compacted filling material

Areas of ground may have been filled with soil or other materials without it being properly compacted. Cracks appearing around the perimeter of a dug area are signs that the area has not been properly compacted.

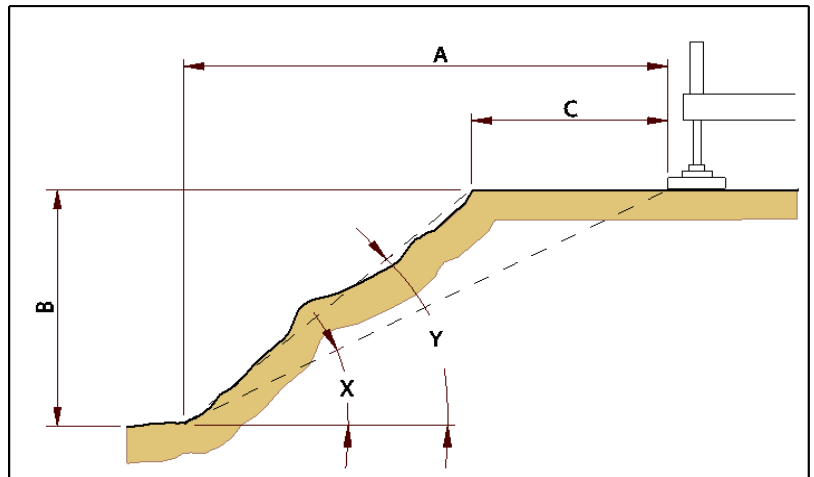

3) Proximity to dug areas

The machines must not be positioned near the edges of earthworks or other excavations as they are likely to subside without warning. If the machine has to be positioned near the edge of a slope or a dug area with the outriggers or wheels in a 'hazardous area', a technical assessment report should be sought from a skilled geotechnical engineer before setting up the MEWP and rendering it operational.

The safety distances and slope angles stated must be maintained (see drawing).

A - Safety distance

B - Hole/trench depth

C - Distance from the edge of the embankment

- If the truck/machine assembly has a GVW of up to 12t, the distance must be ≥ 1.00 m
- If the truck/machine assembly has a GVW of over 12t, the distance must be ≥ 2.00 m

Y - Load transfer angle

- If " $Y \leq 30^\circ$ " on ground which is loose or non-compacted " $A \approx 2 \times B$ "
- If " $Y \leq 45^\circ$ " on compacted ground " $A \approx 1 \times B$ "

X - Embankment angle

Unless the stability is proved mathematically, the following embankment angles must not be exceeded:

- a) for non-compacted or loosely compacted ground " $X = 45^\circ$ "
- b) for firm ground or semi-solid, compact ground, " $X = 60^\circ$ "
- c) for rock " $X = 80^\circ$ "

2.2 CONDITIONS FOR OPERATION

ASSESSMENT OF THE GROUND (continued...)

4) Paved areas, basements, and semi-basements

Many paved areas, basements, and semi-basements are unable to withstand the load of a platform and could collapse without warning. The suitability of the flooring and the location of the basements and semi-basements must be taken into account.

5) Areas paved with slabs

Paving slabs can appear strong while hiding a weak floor underneath. Caution must always be taken with pavements as they could have been made from poor quality materials or might hide work that has been carried out underneath the surface. If a road is subject to constant heavy goods traffic and does not show any signs of wear, then it may be less hazardous than a car park or a less-used country road.

6) Underground works

All underground cavities, such as sewerage, drainage canals, wells, manholes, pipelines for gas, water, power cables, and other pipelines, tunnels, abandoned cemeteries, old water holding tanks, septic tanks, etc. could be damaged by the weight of the machine or could even cave in, either leaving the machine unstable or causing it to overturn.

7) Weather conditions

Heavy rain or extended rainy periods could alter the conditions of the ground, causing outriggers and wheels to sink. If you suspect subsidence in the ground where the MEWP needs to stand, check the level of the machine regularly and make the appropriate adjustments to the outriggers, ground shoring, etc. Regular checks must also be made when icy ground begins to thaw, as it could look much stronger than it actually is.

Spreader Plates

These spreader plates with built-in handle are made of an abrasion-resistant synthetic material and can be supplied by KLUBB to suit your MEWP.

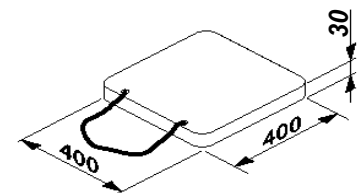

Do not stack plates on top of each other as they could slide off.

When lowering the outrigger onto the spreader plate it must always be positioned so that it is in the centre of the recessed area.

The surfaces of the spreader plate and of the outrigger must be touching completely, with neither resting on the edges. The outriggers must always be properly supported.

Both sides of the spreader plates must always be kept clean. The plates must be dry and must have no oil or grease on them, nor ice, lubricants, or any other slippery products.

Make sure you use the spreader plates properly and ensure uniform support.

Divide the maximum support reaction specified on the warning decal on the outriggers by the surface area of a spreader plate (in cm²). The result is the pressure applied by the machine to the ground (when using spreader plates) which must be compared against the pressure values stated on the decal.

For example: maximum outrigger reaction (see rating plate) = 22000 N, surface area of a 40 cm x 40 cm spreader plate = 1600 cm², soil compression = 13.75 N/cm²

According to this calculation, it is clear that when using the spreader plate, the supporting surface area is enlarged to such an extent that the bearing capacity of ground with a road surface is never exceeded. In areas with loose soil, be aware that the use of spreader plates may still not be enough!

2.2 CONDITIONS FOR OPERATION

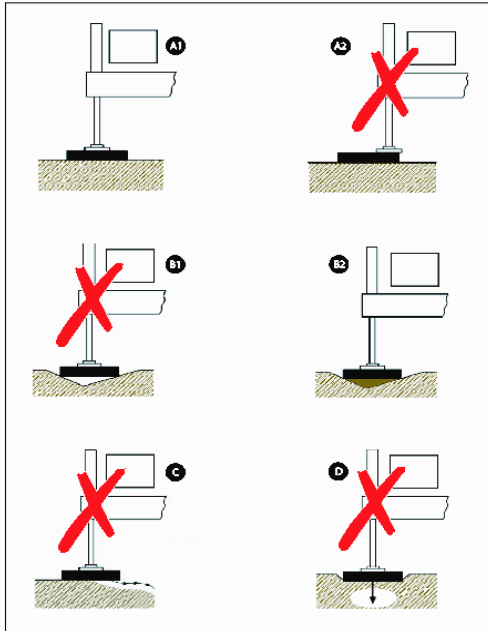

CORRECT OUTRIGGER POSITIONING

- A1 - Correct
- A2 - Outrigger not centred on plate
- B1 - Plate on top of a hole
- B2 - Suitably filled hole
- C - Loose ground which has been swept away by rain
- D - Outrigger positioned on top of a cavity

OVERHEAD POWER LINES

Great care must be taken when operating near overhead power lines. The access platform has no insulation properties so a safe distance must be maintained at all times. If the unit is fitted with a plastic basket this can offer a minimal amount of protection to the personnel in the basket but only in the right conditions.

Only access platforms certified as Insulated Aerial Device (IAD) can work near overhead power lines.

A minimum safe distance must always be kept between the overhead lines and the closest point of the MEWP when fully extended. This distance is 15m with overhead lines mounted on steel towers and 10m with lines mounted on poles of wood. These distances are measured horizontally at ground level from a position vertically below the outermost conductor at the tower or pole position.

kV	Minimum admissible distance	
	M	ft
≤ 1	3.5	11'5"
10	4	13'1"
15	4	13'1"
132	5	16'4"
220	7	23'
380	7	23'

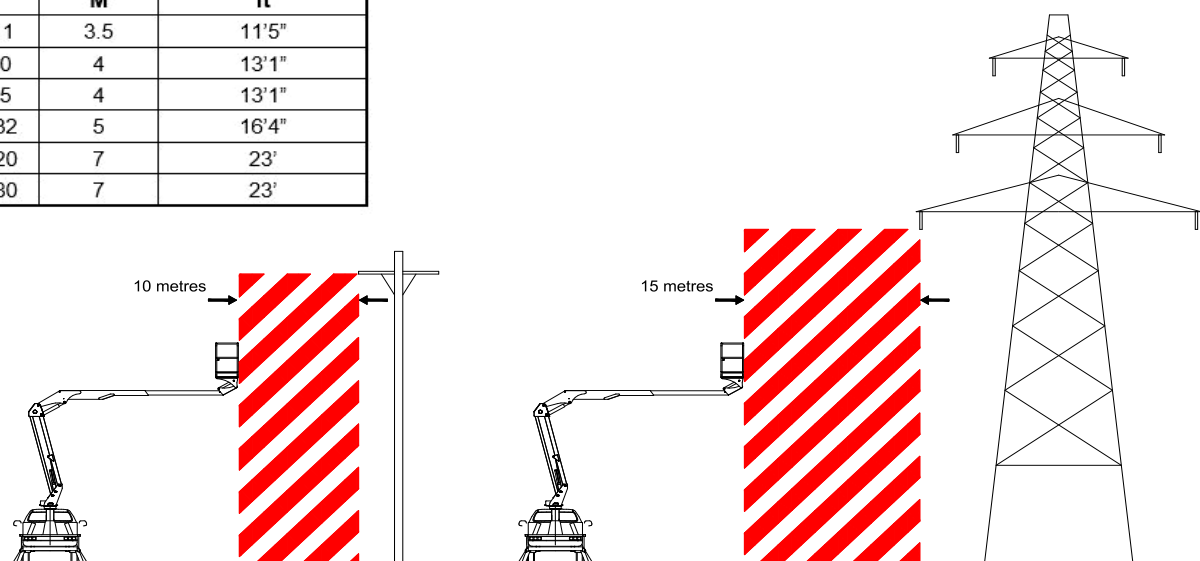



2.3 RECOMMENDATIONS FOR USE

NEVER USE THE MACHINE:

- in a work area exposed to fire risks; during thunderstorms; or in corrosive, flammable, or explosive atmospheres, or in the presence of harmful dusts.
- with the engine running in an area which is not well ventilated. When using the machine indoors or in poorly ventilated areas, adopt all necessary precautions to prevent build-up of toxic exhaust gas.
- at night or in poorly lit environments if not equipped with a floodlight.
- in the presence of intense electromagnetic (EM) fields (e.g. telecommunications pylons, radar systems or suchlike) unless a suitable technical assessment of the situation has been made. Generally speaking, the distance to be maintained between the system installation area – which can be defined as a “controlled-access area” in relation to EM exposure – and the other freely accessible work areas, depends on the technological characteristics of the equipment and must be taken into account by the responsible person who carries out the risk assessment.
- on public roads. If the machine is used on roads open to traffic, suitable signs must be set up and the work area cordoned off, both for safety purposes and to comply with laws in force.
- with unauthorised persons standing or moving within the work area. The operator must stop the machine and clear the work area of any unauthorised persons that may be there.
- at events and shows without taking certain precautions to prevent accidental movements and to protect the general public. Bear in mind any changes in the environmental conditions which could alter the consistency of the ground; the wind; and possible hydraulic leakage.
- if a failure has been detected. All work must be stopped until the fault has been remedied.
- when the machine has not been properly inspected and serviced.
- without safety devices.
- as a crane, for lifting loads or to pull or tow anything.
- with loads over the level permitted on the work platform (people + equipment).
- with a lateral force in the platform over the level permitted.
- if there are obstructions on the platform.
- when it is loaded on vehicles, ships, scaffolding or such like.
- with material or objects suspended from the structure.
- as an earth for the welding machine.



2.3 RECOMMENDATIONS FOR USE

ALWAYS COMPLY WITH THE FOLLOWING INSTRUCTIONS:

- Do not allow unauthorised persons to use the machine. Make sure the machine cannot be accessed by any unauthorised persons when out of use. Remove the access/ignition keys when the machine is not in use.
- Wear personal protective clothing and equipment, as per applicable regulations. To find out what should be worn, contact your employer or safety manager.
- Always follow the instructions and the signs affixed to the machine.
- Do not remove any of the machine's parts, nor the ballast. Stability is only guaranteed if all parts of the machine are fitted in the same way as when the machine was delivered.
- Do not tamper with the control systems or the safety devices in order to increase performance.
- Be careful not to lower the outriggers onto anyone's feet.
- After stabilising the machine, check that the plate on each outrigger is resting on the ground properly.
- Do not access the work platform once the structure is extended or leave it if it is not in the resting position.
- Wipe up any oil or grease found on the footboards, deck, or handrails.
- Keep a firm hold on the handrails when boarding or exiting the platform.
- Never control the machine from the ground when there is an operator on the work platform, unless the working conditions allow no other safer and/or better alternatives in terms of the safety of the operator controlling the machine, in which case the relative risks must be assessed beforehand (by the employer). Furthermore, the ground control operator's view of the work platform and the surrounding work area must be sufficient to allow the worker to perform manoeuvres safely.
- Only load the work platform when it is fully lowered and resting on the ground.
- Do not climb on the work platform crossbeams; use ladders or any other device provided to reach higher levels.
- When working, do not lean out of the platform or take up precarious positions.
- Be careful not to drop objects or equipment from the platform and make sure they are placed correctly inside the platform. Likewise, these objects must be placed on the platform using a handling cable.
- Take measures to prevent risks of objects falling from the work platform and onto the machine's structure in general.

Mechanical risk: Contact with the machine's moving parts can lead to the risk of crushing and shearing of body parts.

Thermal risk: Contact with hot parts may cause burns.

Fire risk: Fuel leaking from the tank during machine use or during refueling may lead to a fire risk. Never fill the fuel tank near naked flames.

Collision risk: Prior to any machine use, the operator is required to evaluate the risks overhead.

Risk of high-pressure spurts: A pipe or hose breaking or high-pressure oil leakage may lead to injuries and skin

Risk of slipping or falling: Oil, grease, snow, or ice on the steps used to access the manoeuvre stations or on the work platform floor may cause the operator to slip and fall.

Risk of swinging/overturning: Subsidence (be careful during thaw periods in the winter). In the event of sudden gusts of wind (with particular reference to swinging overhead power lines).

2.4 OPERATING PERSONNEL

The machine may be used solely by personnel who meet the following minimum criteria:

- Suitably trained persons
- It is advisable, but not necessary, to have two operators so that one of these can:
 - Act quickly in an emergency.
 - Take over the controls in the event of an accident or failure.
 - Supervise and prevent movement of cars and pedestrians around the platform.
 - Help operate the machine, if necessary.
- Maintenance and testing personnel (when their particular skills are required)

Only the persons listed above are authorised to enter the machine's work area; they may only access the area to carry out their duties and must always advise the operator or designated worker beforehand.

To use the machine, operators must:

- Demonstrate that they are physically and psychologically able, in order to avoid posing risks both to themselves and to others;
- Demonstrate that they are able to understand the contents of this instruction manual (including the drawings and diagrams), in particular the symbols and instructions on the signs affixed to the machine;
- Be familiar with the emergency procedures and able to put them into practice;
- Be able to operate the machine (including any accessories installed);
- Be familiar with the applicable safety regulations.

Operators must not:

- Be engaged in any other activity which could distract them while they are at the controls of the machine;
- Operate the machine while under the influence of alcohol or drugs which impair physical or mental capacities;
- Abandon the machine when the work platform is raised;
- Use the machine in the event of malfunctioning.



2.5 SAFETY DEVICES



On no account must you tamper with the safety devices. Use of the machine is forbidden if the seals have been removed.

Outrigger and Boom Interlocks

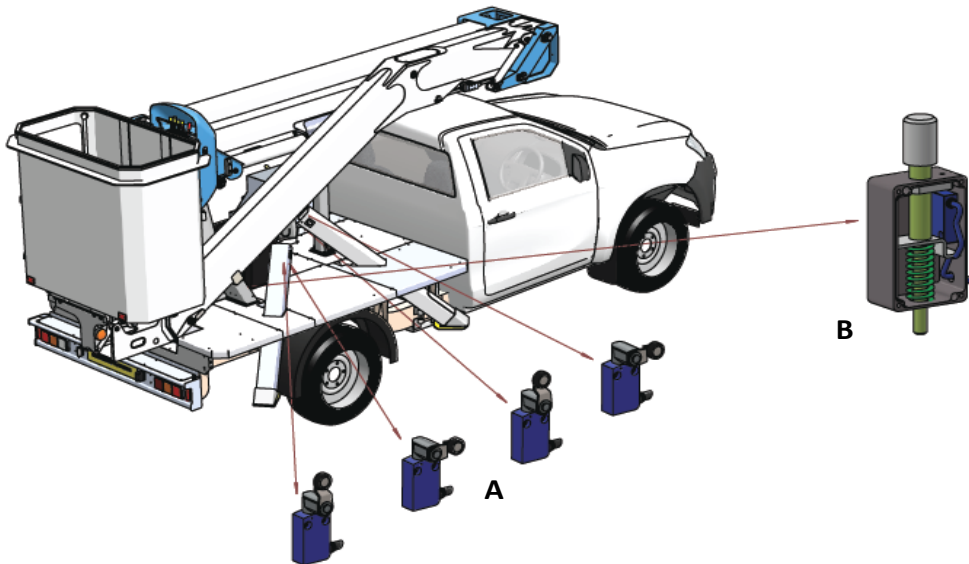

This is a safety feature that prevents the boom from operating until the outriggers are correctly deployed and also prevents the outriggers from being retracted if the platform is not correctly docked.

Each outrigger has 2 micro switches (**Fig A**), one detects when the outrigger is deployed and has ground pressure and the second one detects when the outrigger is un-stowed.

The platform docking mechanism (**Fig B**) is equipped with 2 micro switches, one inside the docking seat and one situated inside the platform at the end of the telescopic boom. These detect when the boom is in the correct docking position.

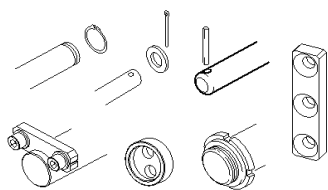

Locking Devices/Pin Retainers

The hinge and stop pins on the mechanical part (outriggers, arms, etc.) and the hydraulic parts (outriggers) are provided with locking devices to prevent them sliding out.

Lock Valve

Positioned on each jack, these valves prevent the outrigger moving in the event that a hose bursts or there is a drop in the hydraulic system pressure.

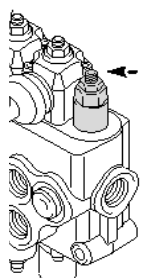
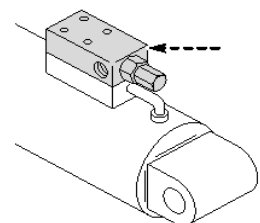

Pressure Valves

Located on all the hydraulic distribution units. To prevent overloading, these relieve operating pressure when it exceeds the maximum set-point. The valves are set and sealed by the manufacturer during testing and must not be altered.

2.5 SAFETY DEVICES

Basket Levelling

This is used for manual basket (trimming) levelling. It is equipped with lock sleeve manual clutch to avoid involuntary operation. It is situated at the basket controls.

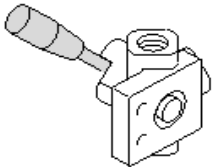
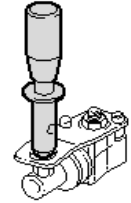

Override Valve for Stabilisers

This is used for retracting the stabilisers in an emergency situation

Emergency stop button

The emergency stop can be activated at the main control box or in the basket. If there is any emergency or danger, press the emergency stop button to stop all machine functions and the power source in use. Before using the machine again, ensure that the dangerous situation is over.

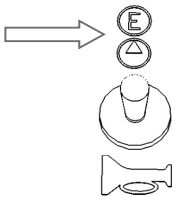
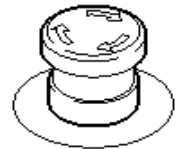

Emergency Electric Motor

This can be operated via a button in the basket or from the deck controls if the hydraulic pump fails.

Emergency hand pump

In the event of the vehicle's engine failure and the electric motor failure, this pump can be used to operate the platform to safely return the machine to the resting position (docking) without employing any override function. This is situated at the deck controls.

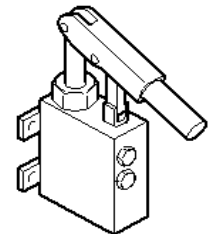

Guards

- A - Guard for deck control station
- B - Guards for micro switches (the guards are fitted to the top of the front and rear outriggers)
- C - Rotation unit guard
- D - Basket control panel guard

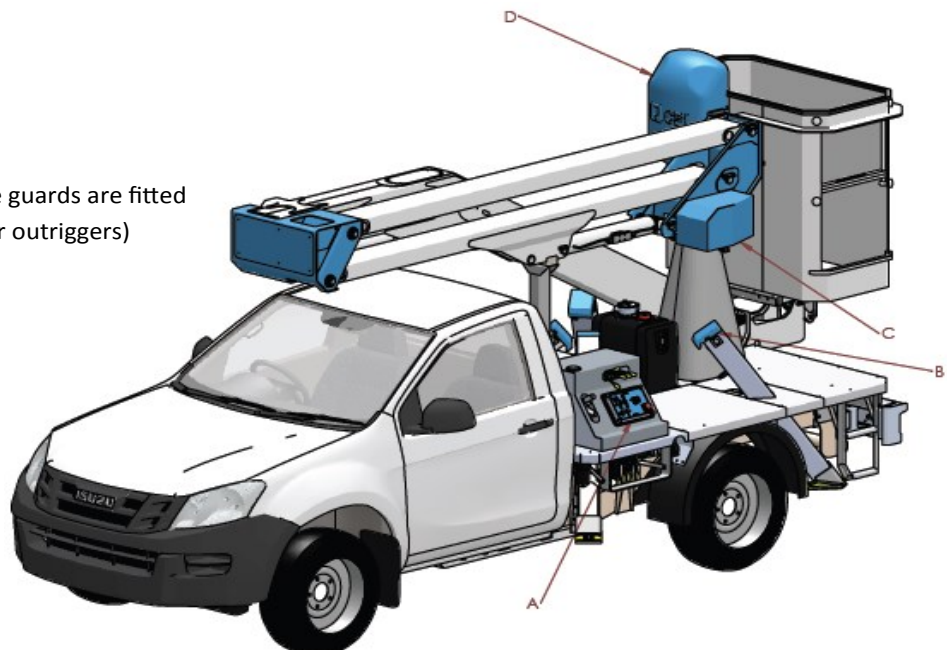

2.6 SAFETY DECALS

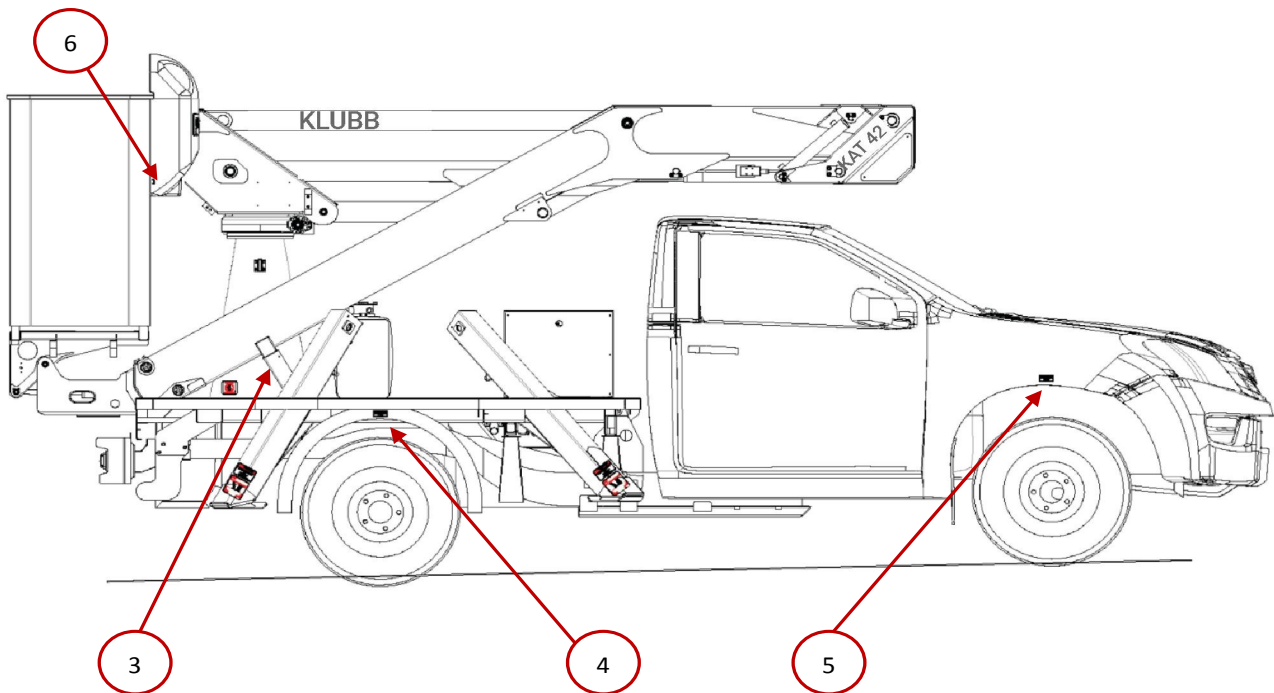
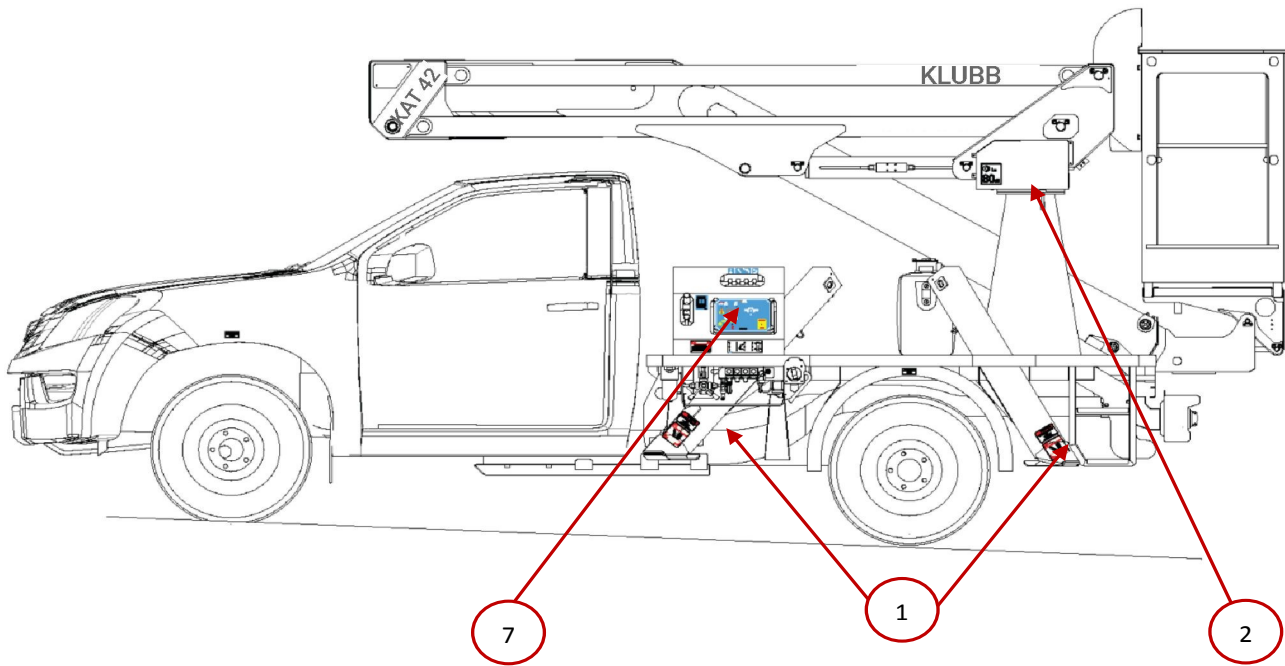



2.6 SAFETY DECALS

1

WARNING

WHEN DEPLOYING THE OUTRIGGERS, ENSURE THAT THE GROUND IS CAPABLE OF SUPPORTING A LOAD OF:
3277Kg
OR A GROUND PRESSURE OF:
6.0kg/cm ON THE FOOT.
1.1kg/cm ON THE SPREADER PLATE

CI10027-30

DANGER

MOVING OUTRIGGER HAZARD
CONTACT WITH MOVING OUTRIGGER WILL CAUSE
DEATH OR SERIOUS INJURY
STAND CLEAR

CI10027-2

2

LWA

80dB

4

TYRE PRESSURE - COLD

PRESSURE - BAR (lbf/in²)

4.4(65)

3

DANGER

CRUSHING

CI10027-5

5

TYRE PRESSURE - COLD

PRESSURE - BAR (lbf/in²)

3.0(44)

6

WARNING

Lower the lower boom fully before stowing the upper boom.

Failure to do so;
Will leave the unit over stated height and put undue strain on basket, boom, and boom rest.

BASKET TRIM (OPERATION)

TO OPERATE BASKET TRIM:

- 1) RAISE DEAD MAN PLUNGER ON LEVER.
- 2) OPERATE BASKET TRIM SPOOL LEVER.
- 3) RELEASE LEVER AND PLUNGER.

DANGER: IMPROPER USE CAN CAUSE DEATH OR SERIOUS INJURY

DANGER

FAILURE TO OBEY THE FOLLOWING WILL RESULT IN
DEATH OR SERIOUS INJURY

- For stationary operation, truck must be securely parked, driving disengaged, and Aerial Device properly stabilized prior to operation.
- To avoid tip-over, outriggers (when so equipped) must be properly extended on a solid level surface.
- Operate all controls slowly for a smooth platform motion and make sure controls are returned to neutral after desired operation.
- Drive must use proper personnel and other protective equipment.
- Never load beyond rated capacity.
- Never operate Aerial Device with personnel under boom or load.
- Never move the truck until the booms and outriggers are in a properly stowed position and secured.
- Refer to the operator's manual for complete instructions. If missing, replace manual.

CI10027-13

WARNING

SWL			
240Kg			
	80KG	80KG	80KG

MAXIMUM ALLOWABLE MANUAL FORCE 400N

RESTRAINT ONLY

FALLING FROM PLATFORM WILL RESULT IN DEATH OR SERIOUS INJURY

MAINTAIN MINIMUM SAFE DISTANCES FROM PYLONS AND CABLES

READ OPERATOR'S MANUAL BEFORE USING PLATFORM

WARNING

DO NOT PLACE OR LEAVE ANY ITEMS IN THIS AREA

DEATH OR SERIOUS INJURY

CI10027-21

WARNING

FAILURE TO FOLLOW PROPER PROCEDURES COULD RESULT IN DEATH OR SERIOUS INJURY

If YOU sell, install, offer for use, use, operate or maintain this Aerial Device
You **MUST COMPLY** with the requirements of your country specific:
National Standards, Health and Safety Regulation.

7

WARNING

Escaping fluid under pressure can penetrate skin causing serious injury.

Relieve pressure before disconnecting hydraulic lines. Keep away from leaks and pin holes. Use a piece of cardboard or paper to search for leaks. Do not use your hand.

Fluid injected into skin must be surgically removed within a few hours by a doctor familiar with this type injury or gangrene will result.

CI10027-22

DANGER

AN UNTRAINED OPERATOR SUBJECTS HIMSELF AND OTHERS TO DEATH OR SERIOUS INJURY

YOU MUST NOT OPERATE THIS MACHINE UNLESS

- You have been trained in the safe operation of this machine.
- You have read, understand and follow the safety and operating recommendations contained in the machine manufacturer's manuals, safety signs attached to equipment, your employer's work rules and applicable government regulations.
- You are sure the machine is operating properly and has been inspected and maintained in accordance with manufacturer's manual.
- You are sure that all safety signs, guards and other safety features are in place and in proper conditions.

CI10027-19

① ↑

② ↑

③ ↑

④ ↑

CI10028-01

PLATFORM SELECTOR VALVE

EMERGENCY OPERATION OUTRIGGER

NORMAL OPERATION

BOOM CONTROLS - EMERGENCY TRIMMED BASKET

CI10028-77

DANGER

OUTRIGGER CONTACT WILL CAUSE SERIOUS CRUSHING INJURY

DO NOT OPERATE OUTRIGGERS UNLESS YOU OR SIGNAL PERSON CAN SEE THAT PERSONNEL AND OBSTRUCTIONS ARE CLEAR OF THE OUTRIGGER AND ITS CONTACT POINT

CI10027-5

DIVERTOR OPERATION JACKS

DANGER: ALWAYS UNDO OVERRIDE AFTER USE AND CHECK OPERATION

22





CHAPTER 3 TECHNICAL INFORMATION



3.1 MACHINE OVERVIEW

The mobile elevating work platform consists of hydraulic boom sections attached to a sub-frame, which in turn is attached to the vehicle chassis. The basket is mounted at the end of the extendable boom structure. The machine is equipped with four outriggers, two at the front of the subframe and two at the rear. The machine is hydraulically powered by a belt driven pump attached to the vehicle's engine. The ground controls are situated on the near side of the machine.

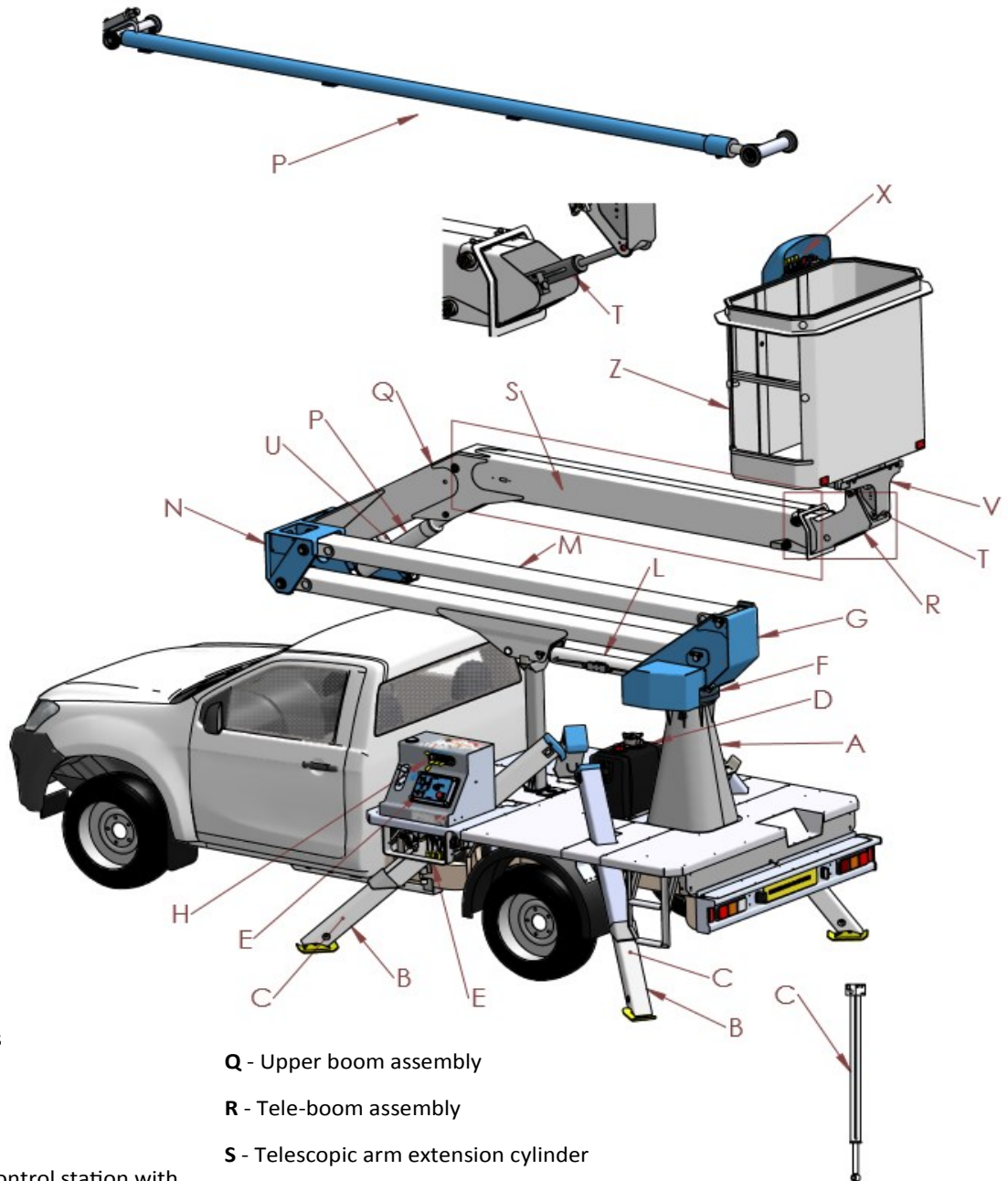

- A - Frame
- B - Outrigger arm
- C - Outrigger cylinder
- D - Hydraulic oil tank
- E - Stabilisation controls
- F - Rotation unit
- G - Column
- H - Secondary ground control station with emergency controls
- L - Articulated arm lifting cylinder
- M - Articulated arm
- N - Knuckle
- P - Telescopic arm lifting cylinder

- Q - Upper boom assembly
- R - Tele-boom assembly
- S - Telescopic arm extension cylinder
- T - Basket levelling cylinder (slave)
- U - Basket levelling cylinder (master)
- V - Basket mount
- Z - Basket
- X - Main controls, Basket

3.1 MACHINE OVERVIEW

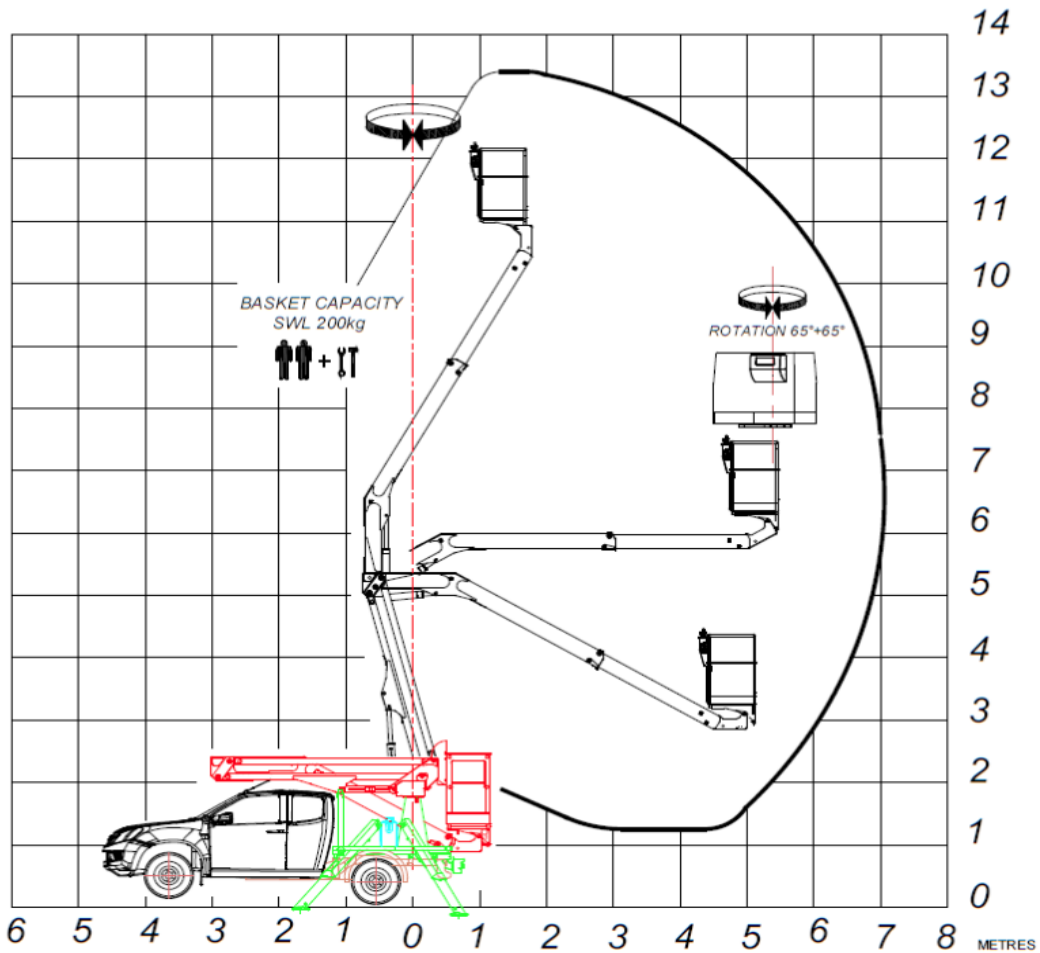
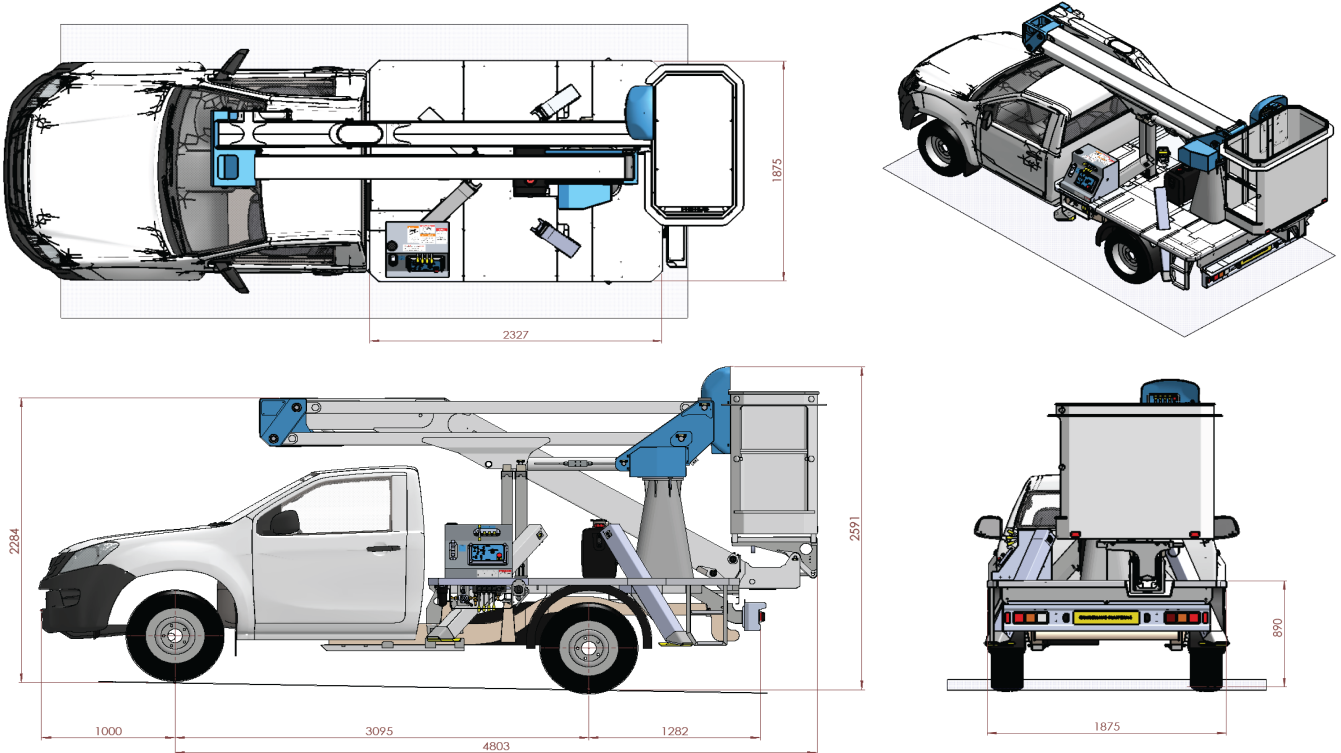

3.2 MACHINE OVERVIEW: HYDRAULICS

No.	PART NAME	QTY
1	PTO pump	1
2	Spool valve, boom controls in platform	1
3	Delivery line filter	1
4	Hydraulic oil tank	1
5	Oil tank drainage cap	1
6	Return filter	1
7	Tap	1
8	Hand pump	1
9	Maximum pressure and closure valve for levelling circuit	1
10	Spool controls, outrigger controls	1
11	Rear outrigger cylinder	2
12	Front outrigger cylinder	2
13	Outrigger lock valves	4
14	Lock valve for platform levelling cylinder	1
15	Slew rotation motor	1
16	Switch for unloading rotation unit at stroke limit	1
17	Electric valve	1
18	Spool valve, boom controls and decking	1
19	Platform levelling master cylinder	1
20	Cylinder manoeuvring for pantograph unit + arm extension	1+1
21	Lock valve for pantograph unit cylinder	1
22	Telescopic arm manoeuvring cylinder	1
23	Lock valve for telescopic arm manoeuvring jack	1
24	Platform levelling slave cylinder	1
25	Telescopic arm extension cylinder	1
26	Lock valve for telescopic arm cylinder	1

3.3 AIR SUSPENSION

ABOUT YOUR KIT

Your vehicle is equipped with an air suspension system designed to improve the comfort and stability of the vehicle and to increase the GVW to 3500kg. It is also possible to control the air pressure from within the vehicle. Your vehicle is equipped with the Comfort Kit shown below.

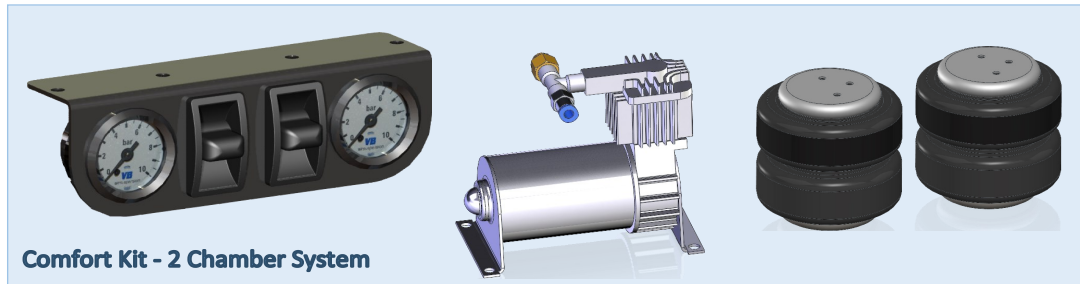

The air suspension system consists of two air bags, which supplement the existing suspension system. These air bags are connected to a compressor kit with a control panel. This is fitted in the vehicles glove compartment. This allows you to adjust the pressure in the semi air suspension. An air bag is mounted on both sides of the vehicle between the body and the axle.

NOTE!! Always make sure that the vehicle is not overloaded. When using the air suspension system, overloading is not visible. If you are in any doubt, we advise you to weigh the axles before driving the vehicle.

OPERATION

NOTE!! Please read all safety instructions prior to operation.

If the vehicle's load makes the vehicle lopsided, you can balance this by individually increasing the air pressure of each air bag. Inflate the system in small steps and check from a distance to see whether the vehicle is level. Pump air alternately into the left and right air springs so that the vehicle is no longer lopsided. The air pressure of the left and right air springs must not differ by more than 0.5 bar. The maximum pressure is always 3.5 bar.

Your two chamber system consists of a control panel with two control switches and two pressure gauges.

The pressure gauges indicate the air pressure of the air bags.

To increase the ride height:

Move the left control switch upwards to inflate the left air bag.

Move the right control switch upwards to inflate the right air bag.

Release the left or right control switch when the desired air pressure or ride height is reached

To lower the ride height:

Move the left and/or right control switch downwards to release air from the bags.

Release the control switch when the desired air pressure or ride height is reached.

3.3 AIR SUSPENSION

SAFETY INSTRUCTIONS

NOTE!! Modifying the suspension system can seriously damage the air suspension. The vehicle may behave in unexpected ways, thereby causing dangerous situations which may result in accidents.

- The maximum air pressure for the system is always 3.5 bar. Make sure that the air bags always have at least the minimum pressure of 0.5 bar. Without this air pressure, the air bags may be damaged while driving.
- The air pressure of the left and right air bags must not differ by more than 0.5 bar. Never pump too much air into the air bags. Driving with excessive air pressure in the air bags can damage the vehicle.
- Only use the air suspension system to raise and lower the vehicle when stationary. Before raising or lowering the vehicle, always secure the vehicle against rolling away and make sure there is no possibility of injury or damage to people and property.
- Do not depress the brake pedal (if possible) while raising or lowering the vehicle. This is advisable to relieve the brake and avoid tension in the chassis.
- Always use a jack or hydraulic ramp to change a wheel or carry out servicing work.
- Do not use the air suspension system when raising one or more axles with a jack or hydraulic ramp.
- The air suspension must not be used to lift wheels from the ground during servicing work (e.g. to change a wheel)
- Errors and/or faults in the air suspension system can have an undesirable effect on driving stability. This may cause the vehicle to sway and/or swing.

**In case of damage or faults that cannot be rectified, contact KLUBB immediately.
If this happens, drive with extra caution at a much lower speed.**

TROUBLESHOOTING

Malfunctions can be diagnosed using the table below. If you cannot correct the fault, contact KLUBB.

Malfunction	Potential Cause	Corrective Action
Compressor not working	Fuse faulty	Replace the fuse
	Battery voltage too low	Charge vehicle's battery
	Control switch faulty	Replace the switch
Compressor does not switch off	Electronic short-circuit	Remove the fuse and contact KLUBB
Air suspension does not raise, even with compressor running	Vehicle overloaded	Reduce load
	Leak in the system	Contact KLUBB to arrange a leak test
	Maximum air pressure reached	Release the switch
Vehicle is lopsided or low (after being parked for a long time)	Leak in the system	Contact KLUBB to arrange a leak test
	Load has shifted	Re-adjust the vehicle height

MAINTENANCE

The air bags, air tubes and compressor must be checked for operation, wear, leaks and damage during servicing. The pressure of the system may fall gradually if it is not used for long periods. To avoid permanent deformation and damage to the air springs:

- The vehicle should be supported with axle stands when not in use for long periods of time
- The air bags should be re-inflated with compressed air once a week
- Soap solution, ethanol, methanol and isopropyl alcohol are permitted as cleaning agents





CHAPTER 4 OPERATION





4.1 PREPARING TO OPERATE THE MACHINE

Before operating the machine you must:

- Be authorised to operate the machine and meet the requirements outlined on page 18, 'Operating Personnel'
- Perform a range of practice manoeuvres to become familiar with the controls
- Follow the instructions for use given in this user manual
- Ensure that you are wearing the correct PPE and that staff on the ground are also wearing safety helmets
- Secure your harness to the harness points provided
- Ensure that there are no collision or crushing risks within the vicinity
- Advise any other operators working on the machine of the type of manoeuvre that will take place and when it is about to begin
- Switch on the beacons (if applicable) to signal work in progress
- Carry out daily checks as per page 47 'Routine Checks'. For safety and to guarantee the machine a long working life, we recommend an all round inspection prior to operating the machine. Ensure that the structure shows no damage or excessive wear and that there are no leaks, loose or missing screws and that the pins are all properly secured. We also advise checking the oil and fuel levels prior to starting work.
- Ensure that all guards and other protective devices are in place and that all safety decals are in place and legible
- Check all emergency functions one by one
- Check that the bar providing access to the basket moves as expected

Do not:

- Stand on the truck, in the cab, or on the deck when the machine is operational
- Overload the truck cab with additional weights when the machine is in use
- Tamper with the machine's devices, as this could cause risk or damage and will immediately invalidate any warranty

4.2 CAB CONTROLS



- A. **PTO Switch:** Push button in, when blue ring light illuminates, the PTO is ready to operate.
- B. **Outriggers Light:** When red light illuminates, the outriggers are un-stowed.
- C. **Beacons Switch (Optional):** Push button in, when amber ring light illuminates, the beacons are switched on.

There are two positions available for optional extras such as beacons or flashing LEDs, this one and an additional not shown.

Audible Warning Buzzer:

This signals the release of the handbrake when the legs are un-stowed or the PTO is engaged. In this instance, the system will automatically switch off the PTO however, the warning buzzer will still sound.

NOTE!! If the vehicle is a Euro 5 Specification then the Cab Controls will be as follows

1. **Signal light (green):** When lit, this shows that the control panel is engaged.
2. **Signal light (amber):** When lit, this shows that the PTO is engaged.
3. **Signal light (red):** When lit, this shows that one or more outriggers is not in the stowed position.
4. **Signal light (green):** When lit, this shows that the boom is fully stowed and safe for driving.
5. **Display:** This shows the number of hours of operation undergone by the machine's electrical system whether the power sources (engine or electric pump) are on or off.
6. **PTO switch:** Push button in, when blue ring light illuminates, the PTO is ready to operate.
7. **Beacon switch:** Push button in, when amber ring light illuminates, the beacons are switched on.
8. **Work light switch:** Push button in, when green ring light illuminates, the work light is switched on.

Audible Warning Buzzer: This signals the release of the handbrake when the PTO is engaged.

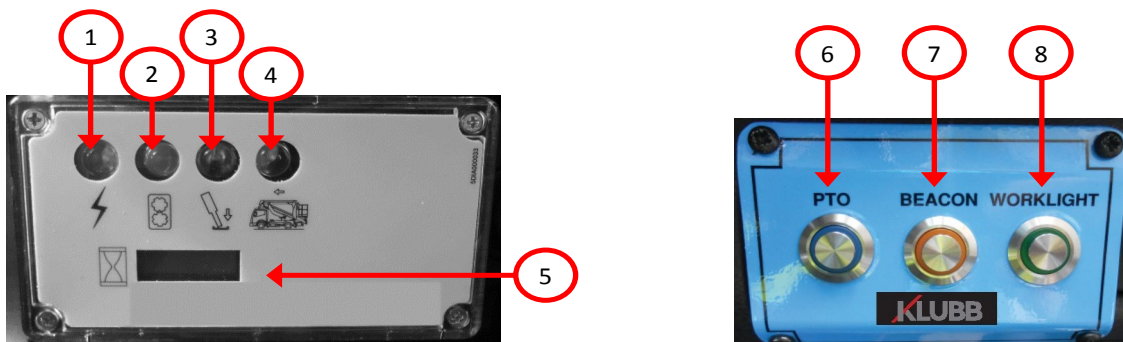

4.3 MAIN CONTROL BOX

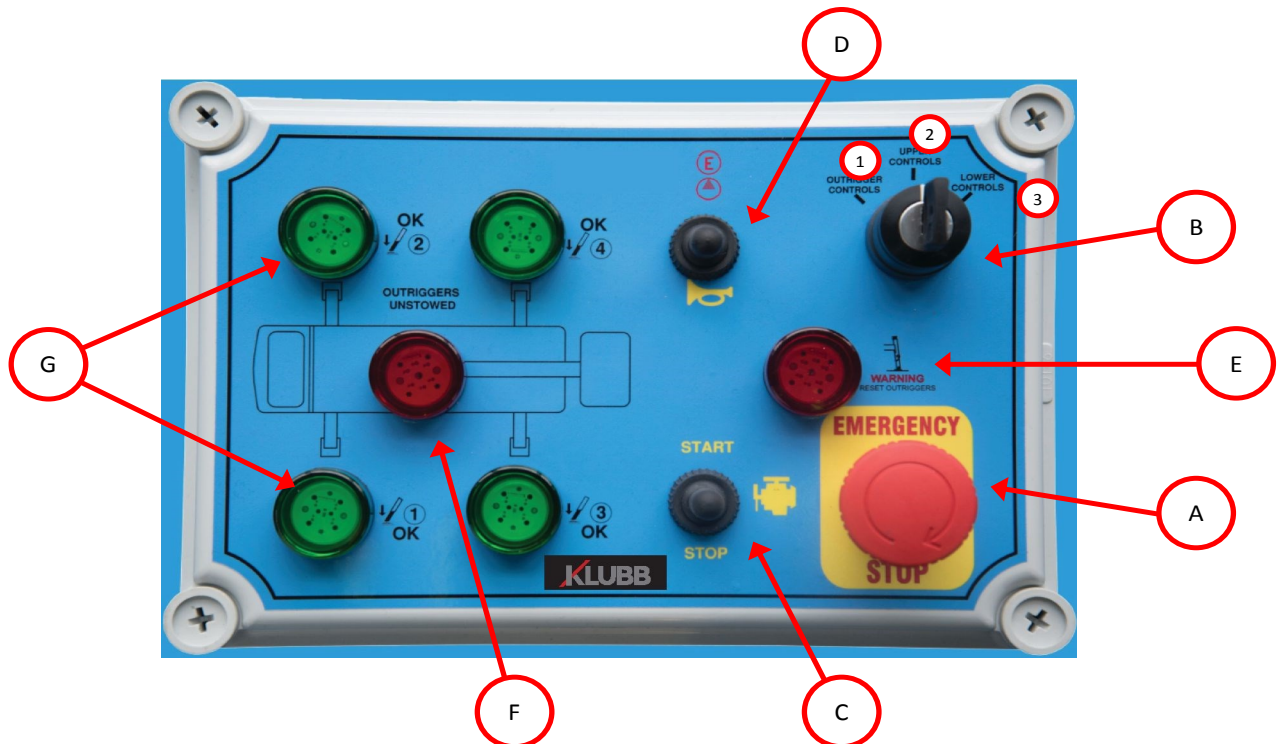

- A. **Emergency stop button:** This is used to stop the machine in situations of imminent risk, deactivating machine operation and the source of power in use (electricity or engine).
 - B. **Three-position changeover switch:** This is used to set the operation mode.
 - Position (1): This activates the outrigger controls
 - Position (2): This activates the upper controls (basket) controls
 - Position (3): This activates the lower controls
 - C. **Engine start/stop:** This is used to start or stop the vehicles engine.
 - ⬆ Up position: Engine start
 - ⬇ Down position: Engine stop
 - D.1 **⬆ Horn switch:** This is used to sound the vehicle's horn to alert people nearby to the machine's presence or the operator's intention to manoeuvre it.
 - D.2 **⬇ Emergency pump:** This is used to electrically retract the boom in the event of hydraulic pump failure.
- Note!! The machine cannot be started from the control panel on the ground if the machine has not been stabilised (it can only be switched off).**
- E. **Warning outriggers reset light:** This light will illuminate and a buzzer will sound to warn that the front outriggers are not stable when basket is in operation. If this light illuminates and the buzzer sounds, you must reset the outriggers.
 - F. **Outriggers un-stowed light:** When the outriggers are out of the rest position, this light will illuminate.
 - G. **Signal lights (green):** When lit permanently, this shows that the associated outrigger is resting correctly on the ground.
 - Signal light 1: LH front outrigger
 - Signal light 2: RH front outrigger
 - Signal light 3: RH rear outrigger
 - Signal light 4: LH rear outrigger

If any of these lights are off, it means that the associated outrigger(s) is not resting properly on the ground.

4.4 DECK CONTROLS

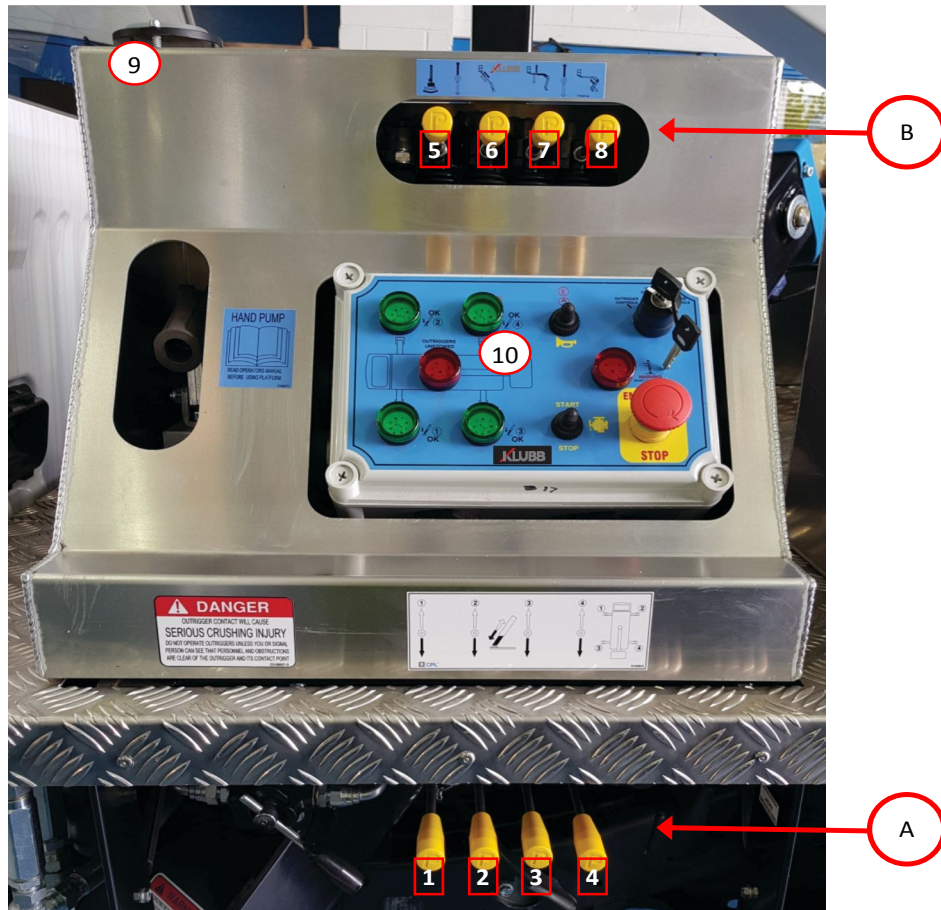

A OUTRIGGER CONTROLS

These levers are used to raise and lower the individual outriggers

Lever (1): Front N/S outrigger control

Lever (2): Front O/S outrigger control

Lever (3): Rear O/S outrigger control

Lever (4): Rear N/S outrigger control

Spirit Level (9): This is used for checking the level during stabilisation

When all four outriggers are deployed and have ground pressure, the four green lights will be illuminated on the main control box (10)

B LOWER BOOM CONTROLS

Lever (5): This lever is used to rotate the platform clockwise and anti-clockwise

Lever (6): This is used to raise and lower the main boom section

Lever (7): This is used to raise and lower the telescopic arm

Lever (8): This is used to extend and retract the telescopic arm

NOTE!! When the levers are in the neutral position, these movements are prohibited.

4.5 BASKET CONTROLS

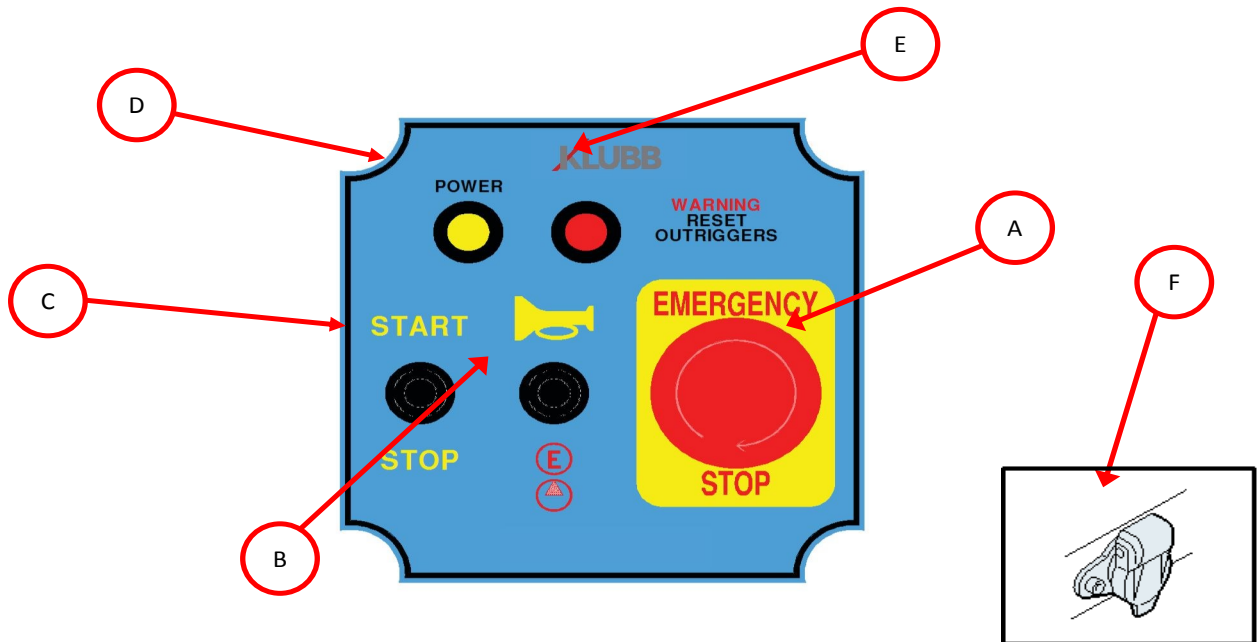

- A. **Emergency stop button:** This is used to stop the machine in situations of imminent risk, deactivating machine operation and the source of power in use (electricity or engine).
- B.1 **Horn switch:** This is used to sound the vehicle's horn to alert people nearby to the machine's presence or the operator's intention to manoeuvre it.
- B.2 **Emergency motor:** This is used to electrically retract the boom in the event of hydraulic pump failure.
- C. **Engine start/stop:** This is used to start or stop the vehicle's engine from running.
 - ⬆ **Up position:** Engine start
 - ⬇ **Down position:** Engine stop
- D. **Signal light (amber):** When lit, this shows that the control panel is powered and that all controls are active
- E. **Signal light (red):** This light will illuminate and a buzzer will sound to warn that the front outriggers are not stable. This applies when basket is in use. If this light illuminates and the buzzer sounds, you must stop using the platform, retract the telescopic section as soon as possible, re-stow the vehicle and then reset the outriggers.
- F. **Supplementary socket:** There is a supplementary 12 V DC—90 W socket on the RH side of the control panel for the use of additional devices.

4.5 BASKET CONTROLS

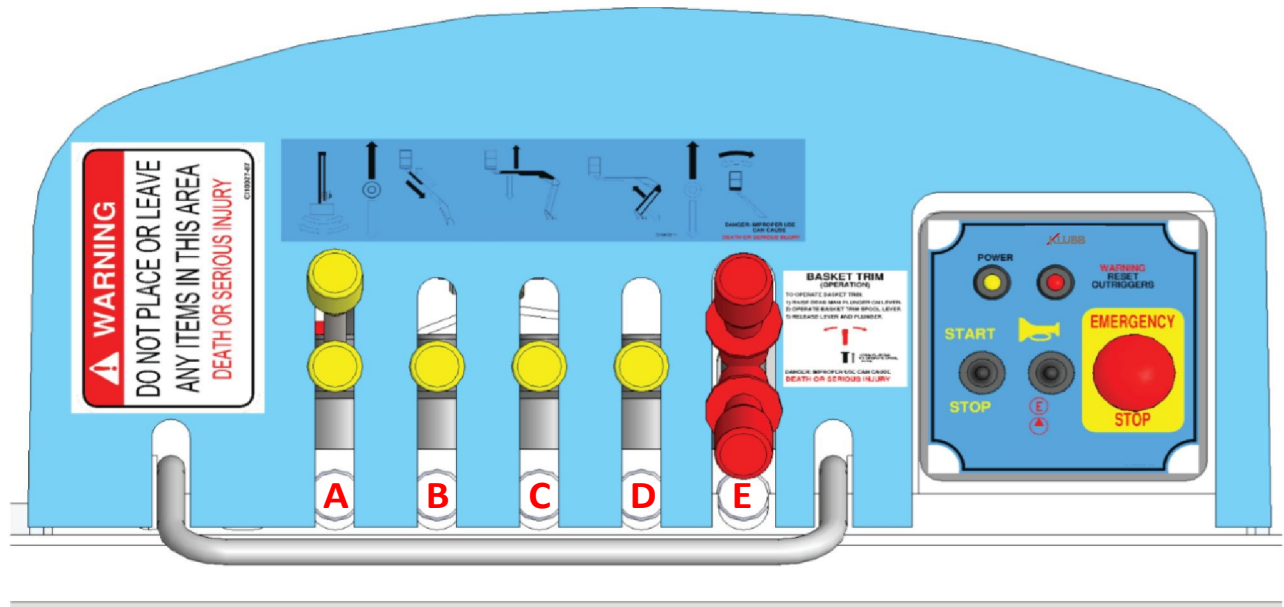

- Lever (A):** This lever is used to rotate the platform clockwise and anti-clockwise
- When the lever is released, it returns to neutral position and this inhibits platform rotation
- Lever (B):** This is used to raise and lower the main boom section
- When the lever is released, it returns to neutral position and this stops the jib lifting and lowering
- Lever (C):** This is used to raise and lower the telescopic arm
- When the lever is released, it returns to neutral position and this inhibits lowering and lifting of the telescopic arm
- Lever (D):** This is used to extend and retract the telescopic arm
- When the lever is released, it returns to neutral position and this stops extension and retraction of the telescopic arm
- Lever (E):** This is used to correct basket levelling by tilting the basket towards/away from the telescopic arm. The sleeve needs to be lifted during operation.
- When the lever is released, it returns to neutral position and this inhibits basket levelling



4.6 STABILISING THE PLATFORM

When stabilising the platform, the operator is responsible for assessing the ground conditions and avoiding hazards and other conditions that could put safety at risk.

Do not stabilise the machine on unstable ground.

Ensure that you are aware of the maximum load that the outriggers will apply to the ground and make sure that the ground is suitable to guarantee the stability of the machine.

We recommend that spreader plates are used at all times.

NOTE!! The machine cannot be stabilised if one or more of the truck doors is open.

Proceed as outlined below to stabilise the machine:

- Engage the handbrake in the truck cab and put the gear lever into neutral (with engine running)
- To engage PTO, press PTO switch **(A)** (Page 34) and the light should illuminate.
- Exit the vehicle and set switch **(B)** (page 35) to **Position (1) 'OUTRIGGER CONTROLS'**
- If necessary, position spreader plates underneath each outrigger.
- Lower the outriggers until they are all resting on the ground but not applying any pressure
 - **Always keep a close eye on the area within which the outriggers move. If the area is not visible from the main control box, fence off your working area to prevent all forms of access.**
- Further lower the outriggers, two by two, until the vehicle's rear wheels are off the ground, checking that the machine is stable using spirit level **(9)** (page 36). If the ground is sloping downwards, lower the outriggers on the lower side before in order to level the machine out
- Ensure all four green outrigger signal lights **(10)** (page 36) are lit
- Walk around the machine to check that the jacks are resting on the spreader plates and there is no movement of the plate.
 - **The front wheels must not come off the ground. They must remain in contact with the ground but with the vehicle's weight lifted off of the suspension.**

4.7 RAISING THE PLATFORM

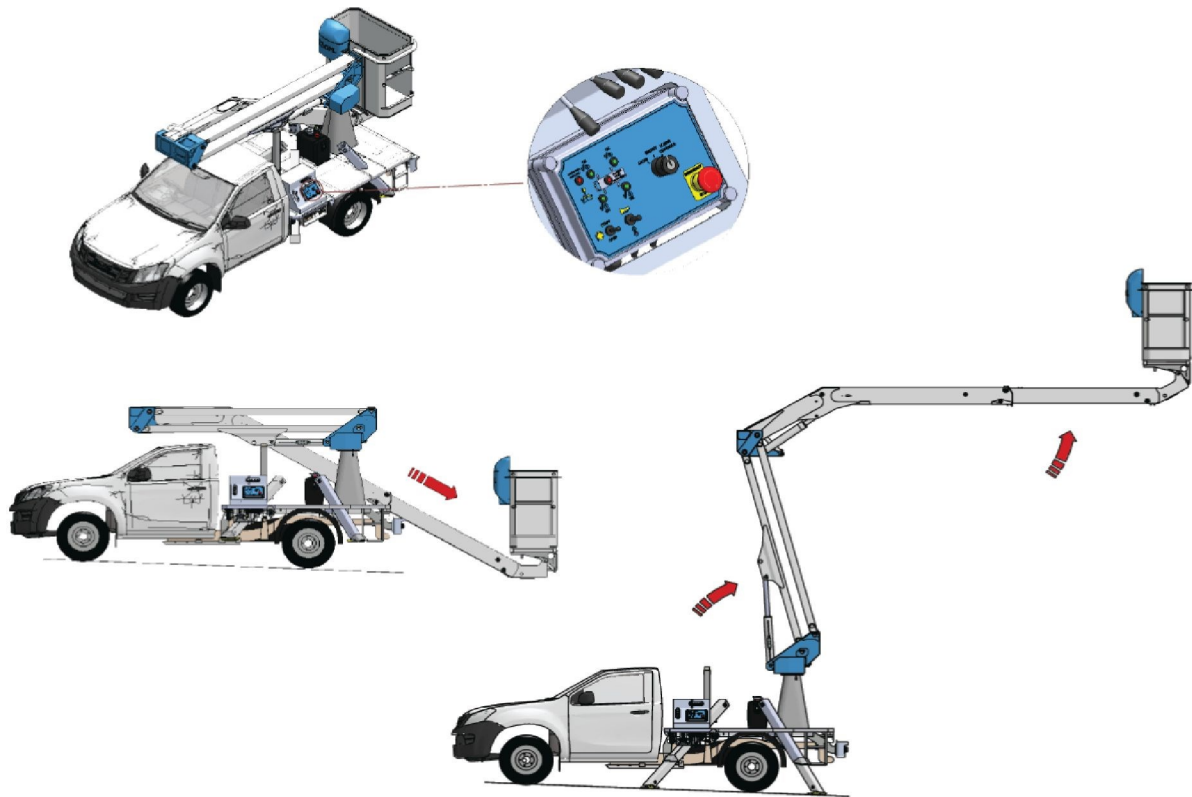

The platform controls can only be enabled if the machine is correctly stabilised and all four jack signal lights **(G)** (page 35) are lit.

To raise the platform, follow the instructions below:

- Select **Position (3) 'LOWER CONTROLS'** on the main control box using the changeover switch **(B)** (page 35)
- Move **Lever (8)** (page 36) down to extend the telescopic arm until the basket is at ground level and ready to enter
- Turn **Control Switch (B)** (page 35) to **Position 2 'UPPER CONTROLS'** to activate the basket controls. (The key can be removed if required.)
- Enter the basket
- Fasten all harnesses and lanyards to the harness points indicated (maximum one operator per harness point) and close the bar behind you
- Move **Lever (7)** (page 36) down to lift the telescopic arm
- Once the telescopic arm has been raised, all other operations can be used

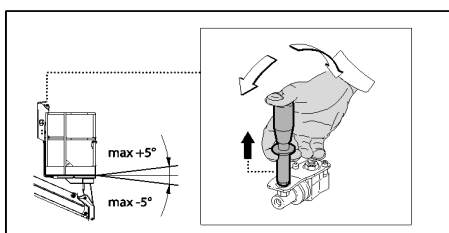

Levelling the Platform

The basket has an automatic hydraulic levelling system fitted, but sometimes the operator will be required to level the basket manually. To operate the manual levelling, lift and move the spring loaded control lever either forward or backwards to incline the basket in either direction by ($\pm 5^\circ$). Once the basket is levelled to the operators' satisfaction release the lever and the spring will return the lever to the locked neutral position.

4.8 CLOSING THE PLATFORM

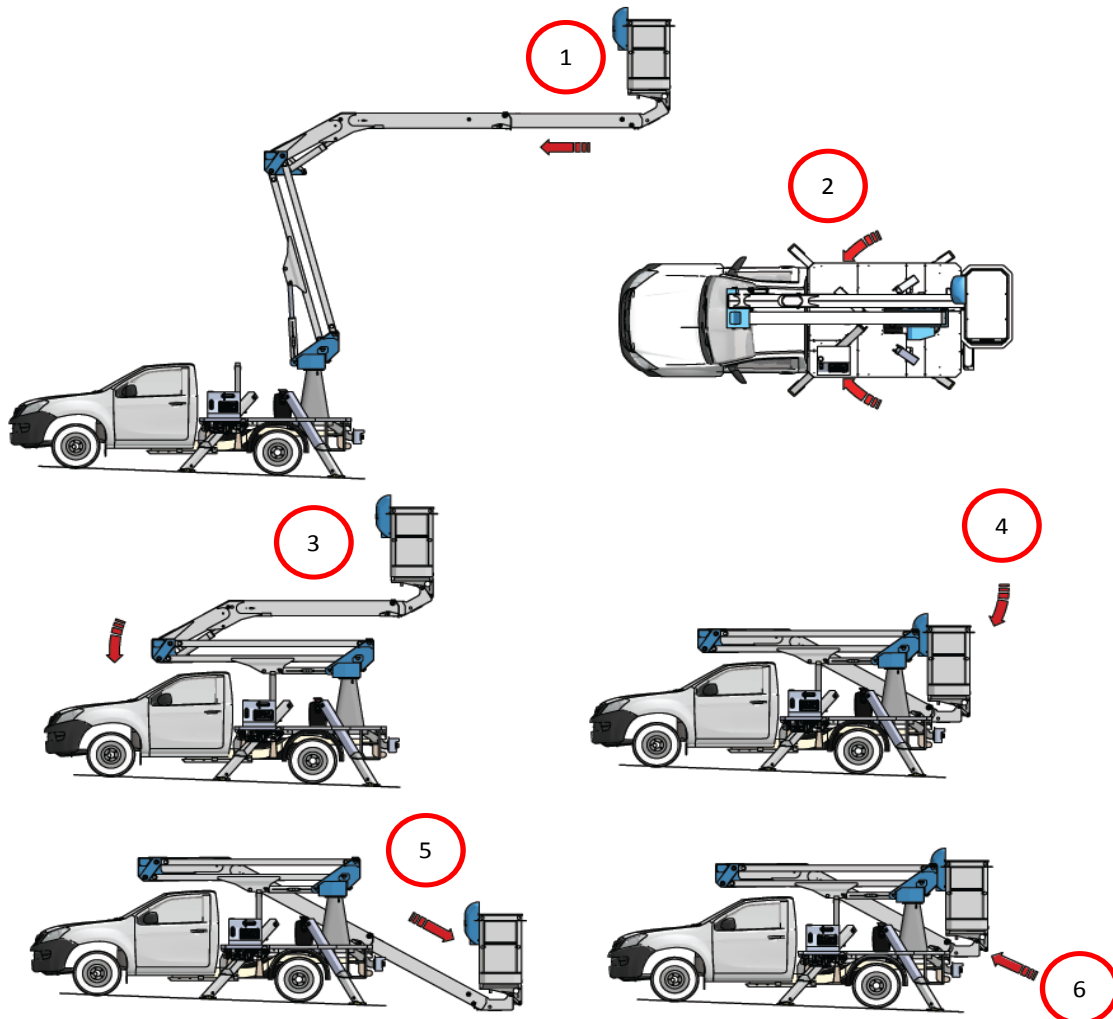

- Retract the telescopic arm fully.
- Turn the platform to align it with the machine's longitudinal axis and in line with the docking pad/rest.
- Lower the main boom section
- Gently lower the telescopic arm until it is resting properly on its support
- Extend the telescopic arm until the basket is near the ground
- Exit the basket and go over to the lower controls
- Use the lower controls to retract the telescopic arm fully
- Use the **OUTRIGGER CONTROLS (A)** (page 36) to progressively lift the outriggers until they are fully retracted and all the vehicle wheels are lowered to the ground
- Remove the spreader plates
- Remove the key from the main control box
- Disengage the PTO in the truck cab.

4.9 EMERGENCY PROCEDURES

It is the responsibility of the operator to carry out a full risk assessment before using the machine at each site in case an emergency procedure is needed.

1) ENGINE AND/OR HYDRAULIC PUMP FAILURE

In the event of engine power failure but electrical system is working, please follow the instructions below to operate the emergency functions:

- From the basket controls, press and hold the emergency motor switch on the electrical box.
- Operate the functions as normal to bring the booms back into the stowed position.



2) IN THE EVENT OPERATOR IS INCAPACITATED OR BASKET CONTROL PANEL FAILURE

- From the lower control station, turn the key switch to lower controls. Press and hold the emergency motor switch on the electrical box.
- Operate the functions as normal to bring the booms back into the stowed position.
- To raise the outriggers from the lower control station, turn the key switch to outriggers.
- Press and hold the emergency motor switch on the main electrical box and raise the legs using the 4 levers under deck.



If the electrical system has also failed, please follow the procedure as outlined below(3).

Note!! The emergency motor MUST NOT be used for more than 3 minutes without a break to prevent overheating

3) ENGINE AND/OR HYDRAULIC PUMP AND ELECTRICAL FAILURE

In the event of engine and electrical power failure, please follow the instructions set out below:

- Ensure the tap at the lower control station is in the correct position as per photo 1.

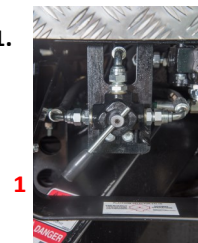

- Locate the emergency handpump handle in the vehicle cab. At the lower control station, insert the handpump handle into the handpump and screw in.
- Whilst pumping the handpump, operate the boom controls as normal to bring the boom down safely. The booms can be fully stowed.
- Once this is completed, break the seal on the tap and move this into the other position as per photo 2.

4.9 EMERGENCY PROCEDURES

- Locate the override knob on the front of the leg lever valve and screw all the way out.
- Remove the plastic spacer and keep this safe.
- Then screw the override knob back into the valve as far as it will go. Do not over-tighten this.
- Whilst pumping the handpump, operate the leg controls as normal to fully retract the outriggers.
- Once completed, remove the handpump handle and place it back in the cab. Unscrew the override valve, refit the plastic spacer and refit the valve.



CHAPTER 5 MAINTENANCE

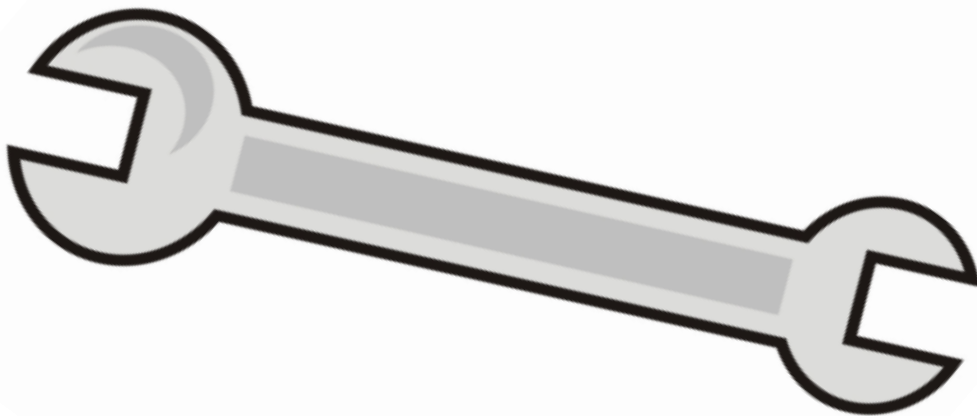



5.1 MAINTENANCE: AN INTRODUCTION

INTRODUCTION

Good maintenance and correct use are essential requirements to guarantee good machine performance and safety. To ensure constant, normal machine operation, original spares supplied by the manufacturer must be used any time a part is replaced. Failure to adhere to these terms may result in the warranty being void and the transfer of all liability to the owner.

The machine you have purchased or hired has undergone compliance testing followed by pre-delivery servicing, which guarantees the machine has been commissioned correctly and all the necessary checks and adjustments have been made.

NOTE!! *The maintenance operations outlined in this manual are given for normal use conditions. In extreme conditions (extreme temperatures, high humidity, atmospheric pollution, high altitudes, etc.), certain maintenance operations must be carried out more frequently and special precautions taken; for use in these conditions, contact the manufacturer.*

PERIODIC CHECKS

After the initial commissioning, the machine must undergo checks by the designated authority (as per UK law) at least once every six months or in compliance with UK regulations.

The owner of the truck is the sole party responsible for ensuring all inspections are carried out.

Look out for any wear which could give rise to hazardous situations (safety devices, load limiters, tilt control devices, leakage from outriggers, deformation/warping, welding condition, tightness of bolts, hoses, electrical connections, tyre condition, and excessive mechanical play).

For the machine's fatigue resistance, in compliance with standard EN 280, reference is made (to err on the side of caution) to a heavy-duty use equivalent to a fatigue dimension of 100,000 cycles.

According to standard EN 13001-3-1 (Table 10), the machine is classified as follows:

- Superstructure: class S1
- Substructure: class S0

After a ten-year life cycle, operating at full capacity, a thorough check of the machine/truck assembly should be performed by an authorised service centre.

NOTE!! *If the machine is hired, the user responsible for the machine is required to ensure the condition inspection and the suitability check are carried out. The user must check with the hire firm that the general and routine checks and the commissioning inspections have actually been carried out.*

REPAIRS AND ADJUSTMENTS

Major repairs or operations on the safety systems or features (related to mechanical, hydraulic, electrical, and electronic systems) and all adjustments must only be performed by an agent authorised by the manufacturer.

Changes made outside the control of the manufacturer are not authorised.



5.2 MAINTENANCE SAFETY NOTICES

When performing maintenance;

- Check that there are no unauthorised personnel in the manoeuvring area (maintenance staff only).
- Always follow the procedures specified for maintenance and technical assistance.
- For all repairs, use original spare parts certified by the manufacturer. Failure to comply with this rule will lead to serious risks for machine safety and stability.
- For more demanding maintenance operations requiring removal of one or more machine components, please contact the manufacturer for specific recommendations to avoid hazardous situations.
- After any parts relating to the lifting structure or essential machine assemblies are fitted or removed, static and dynamic tests must be carried out before the machine is put back into use.
- Any testing operations carried out on the customer's premises must always be performed by trained personnel.
- Perform the operations with a load weighing the same as the Safe Working Load permitted on the work platform.
- Do not allow unauthorised persons to work on the machine. Only qualified, competent staff may do so and always in accordance with the safety instructions concerning personal and environmental protection.
- Do not carry out any work without prior authorisation.
- All maintenance operations not provided for in this chapter must be carried out by authorised, qualified maintenance personnel.
- Disconnect all power supplies and depressurise the hydraulic system every time you perform any maintenance.
- The work platform must be fully closed and lowered to the ground. If this is not possible, place props or stops to prevent sudden machine movements.
- Do not carry out welding, grinding, or boring as this could weaken the machine's structure.
- Do not remove the seals on the valves
- At the end of any maintenance work, before operating the machine, make sure that no tools or unrelated items have been accidentally left on the machine.

5.3 ROUTINE CHECKS

In addition to the required Periodic Checks to be performed by service centres authorised by the manufacturer, you should carry out certain simple preventative checks to ensure safe reliable platform operation.

NOTE!! To benefit from the platform warranty, the information given in this maintenance schedule must be followed exactly.

A . DAILY INSPECTIONS

Every day a visual inspection of the platform is necessary to detect any problems before they become serious. Special attention must be given to the following details:

- 1) **Welds:** All welds must be examined for signs of fatigue. Emerging cracks in a weld are a serious sign of weld fatigue. A few critical welds can be found in the turret area and these call for special attention. Inspect carefully where the flanges of the turrets are welded to the base, where the cylinder armatures are welded to the boom and the cylinder armatures are welded to the turret together with the platform support welds.
- 2) **Cracks/Damage to Structural Parts of the Platform:** All structural parts must be checked for cracks or damage; if found the machine should not be used.
- 3) **Emergency Motor:** Operate the electric emergency motor for 30 seconds to ensure operation
- 4) **Hydraulics:** Check for the following
 - Hydraulic leaks - revealed by hydraulic oil spillage under the vehicle, on the floor or under the mast.
 - Hydraulic pipes - check for cracks, wear and any other damage
 - Hydraulic oil - check the hydraulic oil level
- 5) **Basket:** Check that the basket is free of damage or cracking on the sides or in the bottom. If there is a problem, have the bucket repaired by a qualified repairer before use.
- 6) **Tyres:** Check that the basket is free of damage or cracking on the sides or in the bottom. If there is a problem, have the bucket repaired by a qualified repairer before use.
- 7) **Air Bags:** Check air bags are inflated correctly.
- 8) **Electric Cables:** Check that there is no damage to the protective sheathing.
- 9) **Outrigger Plates:** Check that they are free of damage.
- 10) **Bolts:** Examine all bolts or any signs of loosening. Pay special attention to the bolts holding the ratchet locking tabs or the ratchet lock washers, bearing assembly bolts and rotation supports. Examine the retaining rings, the bolts of the barrels and the torsion bar.

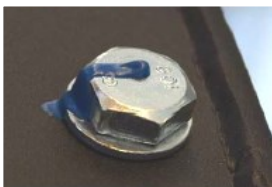

Some critical bolts are marked with torque safety lead seals in order to provide a fast way of detecting any loosening. Do not use the platform if a torque safety seal has been broken. Replace the bolts with a new bolt of the same grade, installed in the specified position by qualified personnel. The photo shows a torque safety lead seal in the unbroken condition.

- 11) **Winter:** During cold periods, take special precaution to avoid freezing by draining or adding anti-freeze products.



5.3 ROUTINE CHECKS

B. WEEKLY INSPECTIONS

In addition to daily inspections, check the following every week:

- Check the operation of the deck controls by using all of its functions, in particular check the operation of the emergency pump.
- Test the operation of the 2 emergency stop buttons situated in the basket and on the deck controls.

C. QUARTERLY INSPECTIONS

In addition to daily and weekly inspections, every 3 months:

- Check the emergency power system ensuring that the switch operates correctly.
- Check the lubrication of the rotation system, platform and stabilisers.

D. SIX MONTHLY INSPECTION

In addition to the checks listed above:

- Replace the hydraulic filter element.
- Check the cleanliness and quality of the hydraulic oil: if it has emulsified or if it is dirty, drain and replace it.
- Check the hydraulic system pressure calibration with the manufacturers' guide.
- Have a CAP certified person inspect and LOLER the machine
- Check main mounting bolts and under chassis support bolts are torqued correctly.

It would be recommended to log these checks that are made in your records, please see an example of a suitable checklist overleaf.

Please refer to the following section **5.4 REGULAR MAINTENANCE CHECKS** for further information and details of how to carry out checks and maintenance on your platform.



5.3 ROUTINE CHECKS

EXAMPLE CHECKLIST

Fill in the checklist during the inspection. Other copies of this checklist can be obtained on simple request to KLUBB.

	Servicing Every Year or 500 hours (whichever comes first)							
	1 year or 500hrs		2 years or 1000hrs		3 years or 1500hrs		4 years or 2000hrs	
	Date	Hours	Date	Hours	Date	Hours	Date	Hours
Hydraulic Leakage								
Oil Filter Change								
Oil Change								
Operating Pressure								
Condition of Hydraulic Unions								
Slew Ring Condition and Greasing								
Rotation Motor Condition and Greasing								
Greasing								
Actuator Condition								
Bucket Condition								
Fastening Torque Loads								
Electrical Wiring Condition								
Corrosion and Distortion								
Emergency Power System Performance								
Elevator Performance								
Signature								
Print Name								
Observations:								

5.4 REGULAR MAINTENANCE CHECKS

Various kinds of adjustments may be necessary during normal machine use and, therefore, these operations come under regular maintenance activity.

HOSING

Checking Condition

Check the seam fastening the fitting to the hose and the condition of the hose.

If the hose shows signs of ageing, breakages, swellings, abrasions etc., it must be replaced.

Check that there are no oil leaks. Oil leaking out from a very small hole can be almost invisible but can create a jet strong enough to pierce skin. When looking for oil leaks, use a piece of card or wood.

Check the condition of the rigid hydraulic pipelines too.

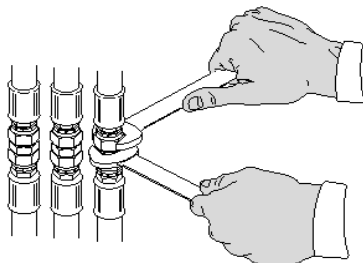
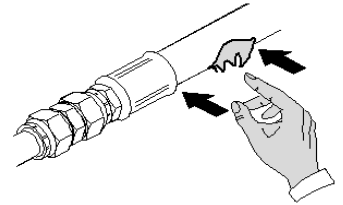

Replacement

NOTE!! The hosing must be replaced with the hydraulic system depressurised.

To depressurise the system, disconnect the PTO, stop the truck engine, and move the control levers both ways.

Unscrew the fittings, collecting the oil in a suitable container.

Replace the hose and tighten fittings.

CHECKING FOR OIL LEAKS FROM FITTINGS

Oil leaks from the fittings can normally be stopped by tightening the fittings correctly.

Oil leaks from the fittings **(A)** equipped with gaskets can only be stopped by replacing the fitting.

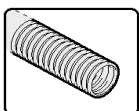
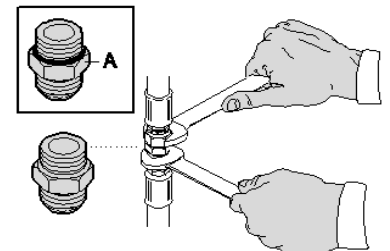

CHECKING HOSING GUARDS

These guards protect the operator against potential oil spurts in the event of hose breakage. If worn or broken, they must be replaced.

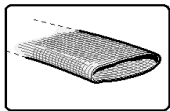

CHECKING THE HYDRAULIC OIL LEVEL

When carrying out this check, the machine must be in the resting position, with all the outriggers retracted and the vehicle located on flat ground. Proceed as outlined below:

- Check the oil level every day.
- To carry out this check, view the level via the glass gauge situated on the side of the tank
- Top up the oil until the level is between the minimum and maximum
- For oil quality, see the section entitled "Oils and Lubricants".

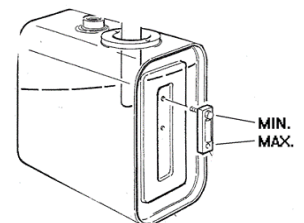

Inside the tank cap there is a filter element for the air breather pipe; the whole cap must therefore be replaced as regularly as the oil filter, as specified in the maintenance schedule.

5.4 REGULAR MAINTENANCE CHECKS

HYDRAULIC SYSTEM FILTER

After the first 20 hours of work, and in general after any maintenance on the hydraulic system, replace the filter cartridges to ensure filter system efficiency.

If there are any solid particles found inside the filter body, contact an authorised service centre.

Checking condition

In any case, replace the filter cartridge as specified on the maintenance schedule.

Replacement

To replace the filter cartridge, proceed as follows:

- 1) Turn off the valve on the tank.
- 2) Clean the filter's outer surfaces carefully.
- 3) Unscrew the filter body (**B**) and drain out the oil.
- 4) Replace the filter cartridge (**C**).
- 5) If damaged, remove and replace the seals (**D**) and (**E**).

To refit the filter, proceed as outlined for its removal but reversing the order of operations.

Tighten the filter body to an appropriate torque rate.

Turn on the cock on the tank.

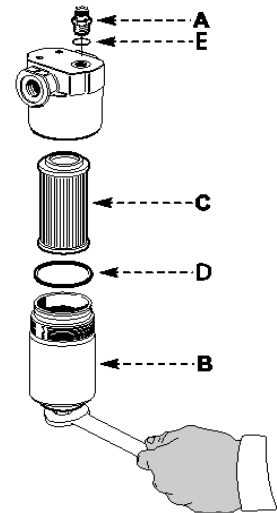

OIL TANK FILTER

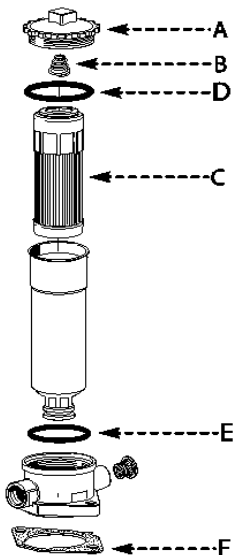

Replace the filter cartridge (as it is made of a non-washable material) as specified in the maintenance schedule

Proceed as outlined below.

- 1) Clean the filter's outer surfaces carefully.
- 2) Unscrew the cover (**A**).
- 3) Remove the spring (**B**) and the filter cartridge (**C**).
- 4) If damaged, remove and replace the seals (**D**) and (**E**), and possibly (**F**).
- 5) Fit the new filter cartridge and the spring (**B**).
- 6) Screw up the cover (**A**).

On the tank cap (**G** – if featured), there is a filter element for the air breather pipe; this must therefore be replaced as regularly as the oil filters, as specified in the maintenance schedule.



5.4 REGULAR MAINTENANCE CHECKS

STRUCTURE INSPECTION

- Clean the machine carefully prior to the inspection.
- Carry out a visual inspection to establish the structure's overall condition, focusing in particular on the welding. If you notice any weakening and/or slight cracks, contact one of the manufacturer's authorised service centres immediately.
- Ensure that there are no loose or missing bolts, nuts or screws, and that the components are securely fastened.
- Make sure the electrical cables are not broken or disengaged.
- Check the condition of the power cable to the control panel(s).
- Check that the warning labels and instruction manual are present.
- Check that the basket and drop down bar are in good condition

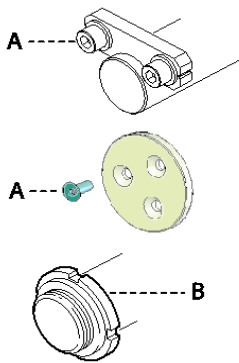

CHECKING THE LOCKING DEVICES

- Check that all the pins and lock pins are correctly in place;
- Check the pin play. If there is any visible movement, the sliding parts must be replaced.
- Check the tightening screws on the pin clamps and the locking devices. If they have worked loose, tighten to the torque rates stated.

SLEWING BEARING BOLT TIGHTNESS CHECK

Check, via an authorised service centre, that the bolts fastening the slewing bearing are tight.

Pos.	Part	daNm
A	Pin clamp screw (M6)	1
	Pin clamp screw (M8)	2.5
	Pin clamp screw (M10)	5
B	Ring nut (M15)	5 - 7
	Ring nut (M30)	12 - 15
	Ring nut (M35)	12 - 15
	Ring nut (M40)	25 - 30
	Ring nut (M45)	25 - 30
	Ring nut (M50)	25 - 30
	Ring nut (M60)	40 - 45
	Ring nut (M65)	40 - 45
	Ring nut (M70)	50 - 55
	Ring nut (M80)	50 - 55

CHECKING THE WEAR PADS

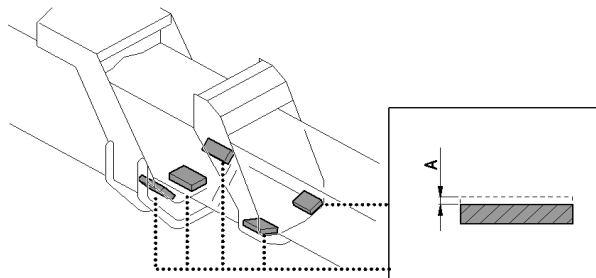

- Perform a visual inspection to check the condition of the wear pads.
- If the wear pads show wear (**A**) amounting to over 3 mm, they must be replaced.
- On no account must the screw heads or the upper part of the clamps that hold the wear pads on the arm protrude from the internal profile of the said pads.
- The wear pads must be replaced by a service centre authorised by the manufacturer.

CHECKING THE OUTRIGGERS

Check that there is no sign of wear, oxidation, or foreign matter on the stem.

Check that there are no oil leaks from the outriggers, in particular from the valves which guarantee the load capacity. In the event that leaks are found, have the gaskets replaced at one of the manufacturer's authorised repair centres.

5.4 REGULAR MAINTENANCE CHECKS

OILS AND LUBRICANTS

Regular lubrication is needed to the machine to prevent excessive wear of moving parts. Never mix different types of oil as this could cause problems for the machine. When topping up, always use pre-filtered oils (max. filter grade: 9, NAS 1638-18/14 ISO 4406).

NOTE!! Please dispose of waste oil safely, in accordance with the Hazardous Waste Regulations.

The following grades of lubricants are recommended for ambient temperatures ranging from -20°C to +40°C; for use in other temperatures please contact the KLUBB Service Department for advice.

OIL	ISO Grade 32	GREASE	EP2 Lithium
-----	--------------	--------	-------------

LUBRICATION POINTS

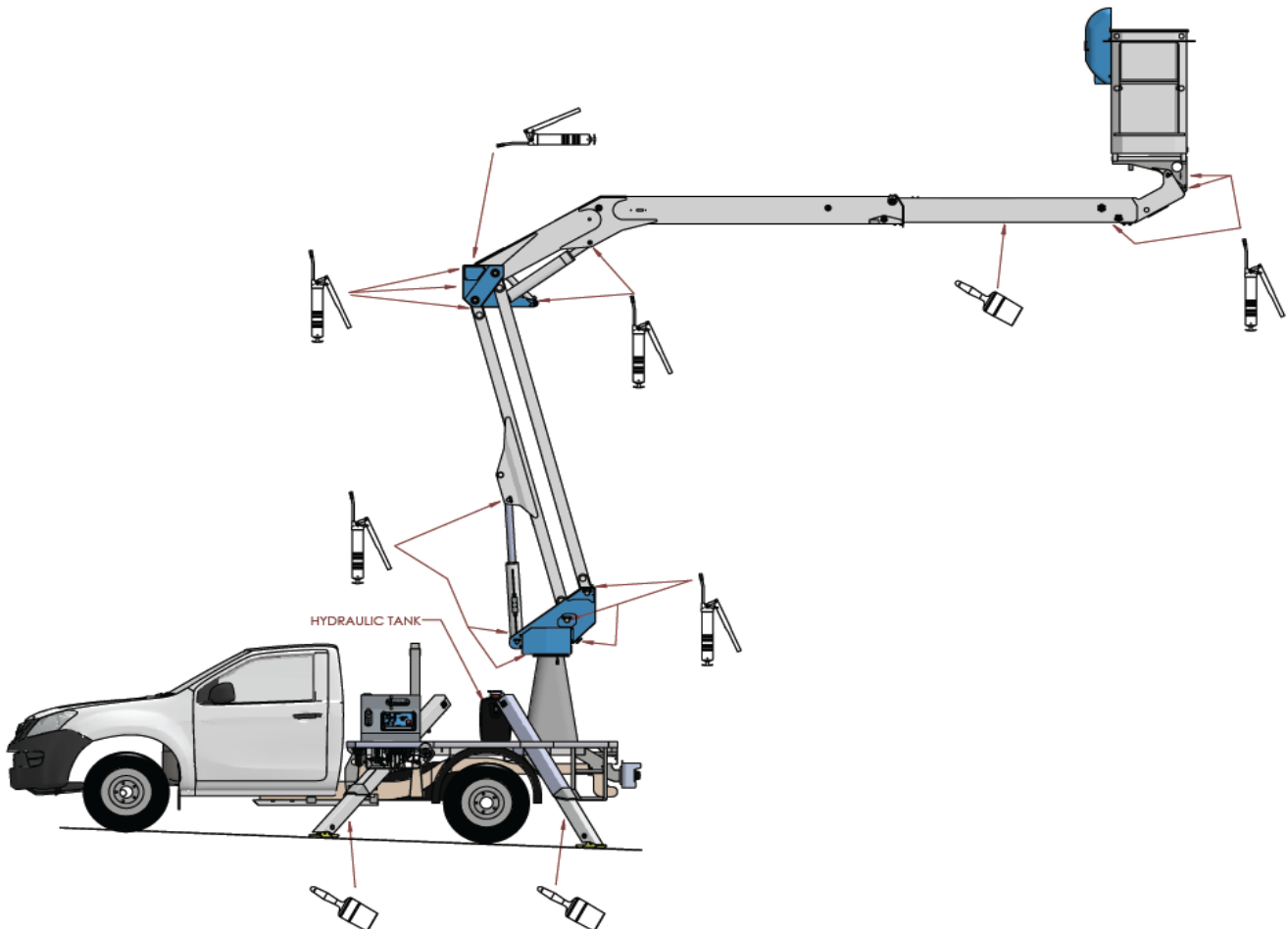

- 1) Lubricate the telescopic arm and the outrigger feet where illustrated regularly, as required.
- 2) Check the lubrication of the rotation system, platform and stabilisers every 3 months as part of the maintenance schedule