



649291 IT-US-NL (15/07/2021)

MRT 1645 400 75D ST5 S1	MRT-X1845400115DST3AS1
MRT 1645 400 115D ST5 S1	MRT 2145 400 115D ST5 S1
MRT-X1645400115DST3AS1	MRT 2145 360 115D ST5 S1
MRT 1845 400 75D ST5 S1	MRT-X2145400115DST3AS1
MRT 1845 360 75D ST5 S1	MRT 2545 400 115D ST5 S1
MRT 1845 400 115D ST5 S1	MRT 2545 360 115D ST5 S1
MRT 1845 360 115D ST5 S1	MRT-X2545400115DST3AS1

MANUALE D'UTILIZZO GRU

(ISTRUZIONI ORIGINALI)

CRANE USER MANUAL

(ORIGINAL INSTRUCTIONS)

HANDLEIDING VOOR HET GEBRUIK VAN DE KRAAN

(ORIGINELE GEBRUIKSAANWIJZING)



IT

PREMESSA

QUESTO MANUALE FORNISCE ISTRUZIONI SUPPLEMENTARI CHE INTEGRANO QUELLE GIÀ FORNITE NEL MANUALE DI USO E MANUTENZIONE DELLA MACCHINA.

IMPORTANTE

Leggere attentamente e comprendere il presente manuale d'istruzioni prima di utilizzare il carrello elevatore.

Contiene tutte le informazioni relative alla guida, alla manipolazione e alle dotazioni del carrello elevatore, oltre alle raccomandazioni importanti da seguire.

Il presente documento contiene inoltre le precauzioni d'uso, le informazioni sulla manutenzione ordinaria per garantire la sicurezza nell'uso e l'affidabilità del carrello elevatore.

IL SIMBOLO CHE VEDETE SIGNIFICA:



ATTENZIONE ! SIATE PRUDENTI ! E' IN GIOCO LA VOSTRA SICUREZZA E QUELLA DEL CARRELLO ELEVATORE.

- Il presente manuale è stato redatto in base all'elenco delle dotazioni e delle caratteristiche tecniche fornite in fase di progettazione.
- Il livello di dotazioni del carrello elevatore dipende dagli optional scelti e dal paese in cui viene immesso sul mercato.
- A seconda degli optional e della data di commercializzazione del carrello elevatore, alcune dotazioni/funzioni descritte nel presente manuale non sono presenti sul carrello elevatore.
- Descrizioni e figure sono fornite a titolo esemplificativo e non hanno carattere vincolante.
- MANITOU si riserva il diritto di modificare i propri modelli e le relative dotazioni senza essere tenuta ad aggiornare il presente manuale.
- La rete MANITOU, composta esclusivamente da professionisti qualificati è a vostra disposizione per rispondere a tutte le domande.
- Il presente manuale è parte integrante del carrello elevatore.
- Deve essere conservato costantemente nella propria ubicazione per ritrovarlo facilmente.
- In caso di rivendita del carrello elevatore, fornire il presente manuale al nuovo proprietario

US

INTRODUCTION

THIS MANUAL PROVIDES SUPPLEMENTARY INSTRUCTIONS WHICH ARE IN ADDITION TO THOSE PROVIDED IN THE VEHICLE'S USE AND MAINTENANCE MANUAL.

IMPORTANT

Carefully read and understand this instruction manual before using the lift truck.

It contains all information relating to operation, handling and lift truck equipment, as well as important recommendations to be followed.

This document also contains precautions for use, as well as information on the servicing and routine maintenance required to ensure the lift truck's continued safety of use and reliability.

WHENEVER YOU SEE THIS SYMBOL IT MEANS:



WARNING ! BE CAREFUL ! YOUR SAFETY OR THE SAFETY OF THE LIFT TRUCK IS AT RISK.

- This manual has been produced on the basis of the equipment list and the technical characteristics given at the time of its design.
- The level of equipment of the lift truck depends on the options chosen and the country of sale.
- According to the lift truck options and the date of sale, certain items of equipment/functions described herein may not be available.
- Descriptions and figures are non binding.
- MANITOU reserves the right to change its models and their equipment without being required to update this manual.
- The MANITOU network, consisting exclusively of qualified professionals, is at your disposal to answer all your questions.
- This manual is an integral part of the lift truck.
- It is to be kept in its storage space at all times for ease of reference.
- Hand this manual to the new owner if the lift truck is resold.

NL

VOORWOORD

DEZE HANDLEIDING VERSTREKT BIJKOMENDE INSTRUCTIES TEN OPZICHTE VAN DE INSTRUCTIES IN DE GEBRUIKS- EN ONDERHOUDSHANDLEIDING VAN DE MACHINE.

BELANGRIJK

Lees en begrijp deze handleiding voordat u deze heftruck gaat gebruiken.

Deze bevat alle nodige informatie over de besturing, de behandeling en de uitrusting van de heftruck, evenals belangrijke aanbevelingen die moeten worden opgevolgd.

U vindt ook in dit document voorzorgsmaatregelen bij het gebruik, informatie over onderhoud en de meest voorkomende servicewerkzaamheden, om het veilig gebruik en de betrouwbaarheid van de heftruck te handhaven.

ALS U DIT SYMBOOL ZIET WIL DAT ZEGGEN:



LET OP! WEES VOORZICHTIG! UW VEILIGHEID EN DE VEILIGHEID VAN ANDEREN EN VAN DE HEFTRUCK LOPEN GEVAAR.

- Deze handleiding is ontwikkeld op basis van de lijst van uitrustingen en technische specificaties bij ontwerp.
- Het uitrustingsniveau van de heftruck is afhankelijk van de gekozen opties en het land van verkoop.
- Afhankelijk van de opties en de verkoopdatum van de heftruck, zijn sommige uitrustingen/functies die in deze handleiding worden beschreven niet aanwezig op deze heftruck.
- De beschrijvingen en illustraties zijn niet bindend.
- MANITOU behoudt zich het recht voor haar modellen en uitrusting te wijzigen zonder daarvoor deze handleiding bij te werken.
- Het MANITOU-netwerk bestaat uitsluitend uit gekwalificeerde professionals die ter beschikking staan om al uw vragen te beantwoorden.
- Deze handleiding maakt integraal deel uit van de heftruck.
- Deze moet permanent worden bewaard op de toegewezen plaats zodat u deze gemakkelijk kunt vinden.
- In geval van doorverkoop van de heftruck, moet deze handleiding worden doorgegeven aan de nieuwe eigenaar.



IT

US

NL

PRIMA EDIZIONE
1st ISSUE
EERSTE VAN UITGAVE

15/07/2021

MANITOU BF S.A Società per azioni con Consiglio di Amministrazione.
Sede sociale: 430 rue de l'Aubinière - 44150 Ancenis - Francia
Capitale sociale: 39.548.949 euro
857 802 508 RCS Nantes.
Tel.: +33 (0)2 40 09 10 11
www.manitou.com

Manitou BF S.A Limited liability company with a Board of Directors.
Head office: 430, Rue de l'Aubinière - 44150 Ancenis - FRANCE
Share capital: 39,548,949 euros
857 802 508 RCS Nantes.
Tel: +33 (0)2 40 09 10 11
www.manitou.com

MANITOU BF S.A Naamloze vennootschap met raad van bestuur.
Maatschappelijke zetel: 430 rue de l'Aubinière - 44150 Ancenis - Frankrijk
Kapitaal: € 39.548.949
857 802 508 RCS Nantes.
Tel.: +33 (0)2 40 09 10 11
www.manitou.com

Il presente manuale è fornito esclusivamente a titolo di consultazione; è vietata qualsiasi riproduzione, copia, rappresentazione, acquisizione, cessione, distribuzione o altro, parziale o totale, e in qualsivoglia formato. Gli schemi, i disegni, le viste, i commenti, le indicazioni e l'organizzazione stessa del documento, riportati nella presente documentazione, sono proprietà intellettuale di MANITOU BF. Qualsiasi violazione a quanto riportato sopra è passibile di condanna civile e penale. I loghi e l'identità visiva dell'azienda sono di proprietà di MANITOU BF e non possono essere utilizzati senza previa autorizzazione espressa e formale. Tutti i diritti sono riservati.

This manual is for information purposes only. Any reproduction, copy, representation, recording, transfer, distribution, or other, in part or in whole, in any format is prohibited. The plans, designs, views, commentaries and instructions, even the document organization that are found in this document, are the intellectual property of MANITOU BF. Any violation of the aforementioned may lead to civil and criminal prosecution. The logos as well as the visual identity of the company are the property of MANITOU BF and may not be used without express and formal authorization. All rights are reserved.

Deze brochure wordt enkel verstrekt ter informatie. Alle reproductie, kopiëren, weergaven, zich toe-eigenen, overdracht, distributie of anderszins, in het geheel of gedeeltelijk, in welke vorm dan ook, is verboden. Schema's, tekeningen, aanzichten, commentaren, indicaties, evenals de organisatie van het document die worden weergegeven in dit document zijn het intellectuele eigendom van MANITOU BF. Elke overtreding van het voorgaande kan leiden tot civielrechtelijke en strafrechtelijke sancties. De logo's en de visuele identiteit van de onderneming zijn eigendom van Manitou en kunnen niet zonder uitdrukkelijke, formele toestemming worden gebruikt. Alle rechten voorbehouden.



IT

1 - SICUREZZA

**2 - DIMENSIONI - USO E
MANUTENZIONE**

**3 - DIAGRAMMI DI CARICO
PER ATTREZZATURE
INTERCAMBIABILI**

US

1 - SAFETY

**2 - DIMENSIONS -
USE AND MAINTENANCE**

**3 - LOAD CHARTS FOR
INTERCHANGEABLE
EQUIPMENT**

NL

1 - VEILIGHEID

**2 - AFMETINGEN - GEBRUIK EN
ONDERHOUD**

**3 - LAADDIAGRAMMEN VOOR
VERWISSELBARE UITRUSTINGEN**



IT

DATI DI IDENTIFICAZIONE DEL COSTRUTTORE

Costruttore: **MANITOU ITALIA S.r.l**
Via C. Colombo, 2
41013 Castelfranco Emilia
(MO) Italia
Telefono +39 059 959811

Dati identificativi, targhe e pittogrammi.
Ogni accessorio è identificato da una targa CE sulla quale sono indicati in modo indelebile i dati relativi ad esso. Per tutte le comunicazioni con il Costruttore e / o Rivenditore, citare sempre questi riferimenti.

Targa Costruttore accessorio:

- 1 - MODELLO
- 2 - CODICE
- 3 - ANNO DI FABBRICAZIONE
- 4 - MASSA A VUOTO
- 5 - CENTRO DI GRAVITÀ
- 6 - CAPACITÀ NOMINALE
- 7 - PRESSIONE DI SERVIZIO

(Vedere Fig. 1)

US

MANUFACTURER'S IDENTIFICATION

Manufacturer: **MANITOU ITALIA S.r.l**
Via C. Colombo, 2
41013 Castelfranco Emilia
(MO) Italia
Telefono +39 059 959811

Identification data, plates and pictograms.

Each attachment is identified by a CE plate which clearly shows the relative data in an indelible manner. For all communication with the Manufacturer and/or Dealer, always mention these references.

Attachment Manufacturer's Plate:

- 1 - MODEL
- 2 - CODE
- 3 - YEAR OF MANUFACTURE
- 4 - MASS WITHOUT LOAD
- 5 - CENTRE OF GRAVITY
- 6 - NOMINAL CAPACITY
- 7 - OPERATING PRESSURE

(See Fig. 1)

NL

IDENTIFICATIEGEGEVENS VAN DE FABRIKANT

Fabrikant: **MANITOU ITALIA S.r.l**
Via C. Colombo, 2
41013 Castelfranco Emilia
(MO) Italië
Telefoon +39 059 959811

Identificatiegegevens, platen en pictogrammen.

Elk werktuig wordt geïdentificeerd met een CE-plaat waarop de gegevens met betrekking tot de bak onuitwisbaar zijn vermeld. Deze gegevens dienen altijd vermeld te worden bij alle communicatie met de fabrikant en/of de verkoper.

Plaat fabrikant werktuig:

- 1 - MODEL
- 2 - CODE
- 3 - BOUWJAAR
- 4 - LEDIGE MASSA
- 5 - ZWAARTEPUNT
- 6 - NOMINALE CAPACITEIT
- 7 - BEDRIJFSDRUK

(Zie Fig. 1)

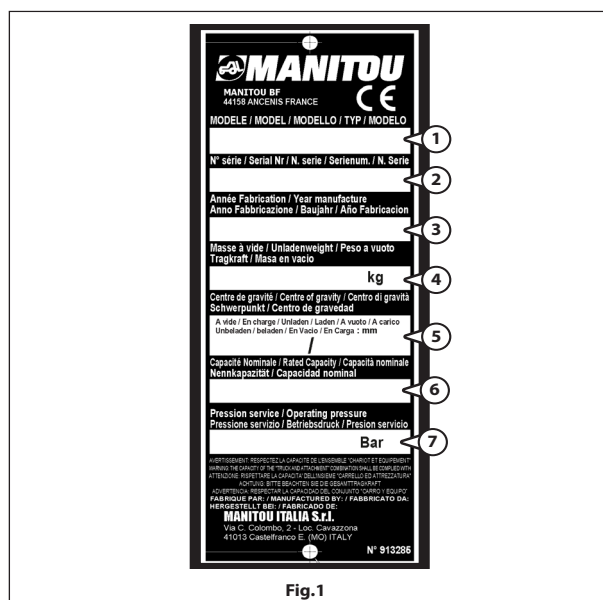

Fig.1



IT
GAMMA BRACCETTI E ARGANI

US
JIB & CRANE AND WINCHES RANGE

NL
ASSORTIMENT ARMEN EN LIEREN

DESCRIZIONE / MODELLO DESCRIPTION / MODEL BESCHRIJVING / MODEL	CARICO MASSIMO DEL CESTELLO MAXIMUM LOAD OF BASKET MAXIMALE BELASTING [kg] (lb)	CODICE PART NUMBER CODE	MRT/MRT-X VISION			
			1645	1845	2145	2545
P 600- extension jib	3000 [6614]	921316	V	V	V	V
P 1000- extension jib	1000 [2205]	921317	V	V	V	V
POTENCE P 1200	1500 [3307]	921318	V	V	V	V
P 1500- extension jib	800 [1764]	921319	V	V	V	V
P 2000- extension jib	1000 [2205]	921320	V	V	V	V
P 4000- 2-hook jib	5000 [11024]	921321	V	V	V	V
P 6000- 2-hook jib	2000 [4410]	921322	V	V	V	V
POTENCE P800 CENTRE FERME	1000 [2205]	921323	V	V	V	V
PT600	1500 [3307]	921325	V	V	V	V
PT1000	600 [1323]	921326	V	V	V	V
POTENCE PT 1200 CENTRE FERME	2000 [4410]	921328	V	V	V	V
PT1500	6000 [13228]	921330	V	V	V	V
PT2000	1500 [3307]	921331	V	V	V	X
POTENCE CROCHET 3 TON - PC 30	2400 [5292]	921332	V	V	V	V
POTENCE CROCHET 4 TON - PC 40	3000 [6614]	921333	V	V	V	V
PC 50- frame-mounted hook	6000 [13228]	921335	V	V	V	V
TREUIL 3T CENTRE FERME+GUIDE	5000 [11024]	921337	V	V	V	V
TREUIL 4T	2000 [4410]	921338	V	V	V	X
TREUIL 5T MRT PLUS	3000 [6614]	921341	X	X	X	V
HBB 1500-2400	3000 [6614]	931627	V	V	V	V
PC 60- frame-mounted hook	800 [1764]	939050	V	V	V	V
TREUIL 5T	6000 [13228]	939109	V	V	V	X
TREUIL 3T UNIQUE BRIN MRT PLUS	6000 [13228]	939111	V	V	V	V
PT 2000	2000 [4410]	939392	X	X	X	V
TREUIL 3T	4000 [8819]	939393	V	V	V	X
W6000/25M	3000 [6614]	52717140	V	V	V	X
W6000/32M	3000 [6614]	52717351	X	X	X	V
J2500 W2000/35M	1200 [2646]	52717582	X	X	X	V
W3000/36M	4000 [8819]	52717650	X	X	X	V
J3000 W1500/43M	4000 [8819]	52717710	V	V	V	V
JE7000 W800/39M	600 [1323]	52717860	V	V	V	V
W3000 DI /48M	5000 [11024]	52717900	X	X	X	V
W3000/23M	3000 [6614]	52718245	V	V	V	X
J2500 W2000/22M	600 [1323]	52718250	V	V	V	X
JW4100/ 600 68M	2000 [4410]	52719496	V	V	V	V
J4100 W1000/34M	1200 [2646]	52719497	V	V	V	V

X	non disponibile, not available, niet beschikbaar
V	Diponibile, available, beschikbaar

IT

US

NL

LEGENDA SEGNI E SIMBOLI

PANORAMICA (Esempio):

	Attenzione! Siate prudenti! E' in gioco la vostra sicurezza e quella del carrello elevatore.
--	--

DATI TECNICI DELL'ACCESSORIO GRU

[kg] (lb)	[t]	[mm] (in) x [m] (ft)	[m/min] (ft/min)	[bar] (psi)	[mm] (in)						[kg] (lb)
					A	B	C	D	E	F	
				P max							
1200 (2204)	5 (5)	Ø 10 (0,4) x 30 (98)	46 (150)	200 (2900)	750 (29)	117 (4)	734 (29)	2692 (106)	2980 (117)	586 (23)	360 (793)

Riferimento	Indicazione (esempio)
1	Carico massimo dell'accessorio gru [1200] (2204)
2	Portata massima del gancio del accessorio gru [5] (5)
3	Diámetro fune Ø [10] (0,4) x lunghezza [30] (98) della fune dell'accessorio gru
4	Velocità massima di salita/discesa fune dell'accessorio gru [46] (150)
5	Pressione massima di esercizio dell'accessorio gru [200] (2900)
6	Dimensioni dell'accessorio gru [mm] (in) (riferite al disegno dimensionale)
7	Massa dell' accessorio gru [360] (793)
8	Sistema metrico [unità di lunghezza (mm, m), unità di velocità (m/min) unità di pressione (bar) e unità di peso (kg, t)] o Sistema imperiale [unità di lunghezza (in, ft), unità di velocità (ft/min), unità di pressione (psi) e unità di peso (lb, t)]

TABELLA DI PORTATA DELL'ACCESSORIO GRU

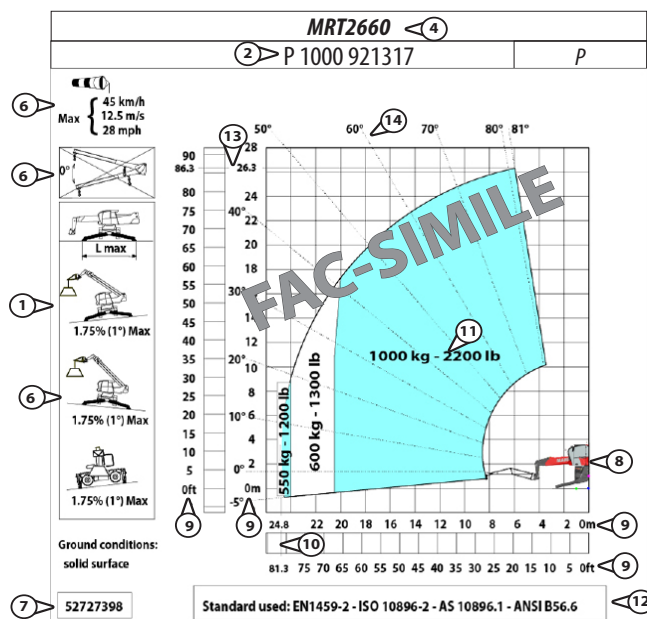

Riferimento	Indicazione (esempio)	Esempio
1	Tabella di portata	
2	Tipo di accessorio gru	P 1000
4	Modello macchina	MRT 2260 +
5	Configurazione di lavoro della macchina: su gomme frontali, su gomme e torretta ruotata, su stabilizzatori	
6	Condizioni d'uso	
7	Codice tabella di portata	52727398
8	Disegno identificativo della macchina	
9	Sistema metrico [unità di lunghezza (m) e unità di peso (kg)] o sistema imperiale [unità di lunghezza (ft) e unità di peso (lb)]	
10	Lunghezza massima di sfilo del braccio telescopico	24,8 m / 81.3 ft
11	Capacità massima di carico dell'accessorio gru in uso	1000 kg / 2200 lb
12	Tabella di portata in base alle norme vigenti nel Paese di destinazione	EN1459 - AS1418.19 - ASME B56.6
13	Altezza massima di sollevamento del braccio	26,3 m / 86.3 ft
14	Angolo del braccio	-5°, 0°, 10°, 20°, 30°, 40°, 50°, 60°, 70°, 80°

IT

US

NL

TABELLA ACCESSORIO GRU "pick and carry"

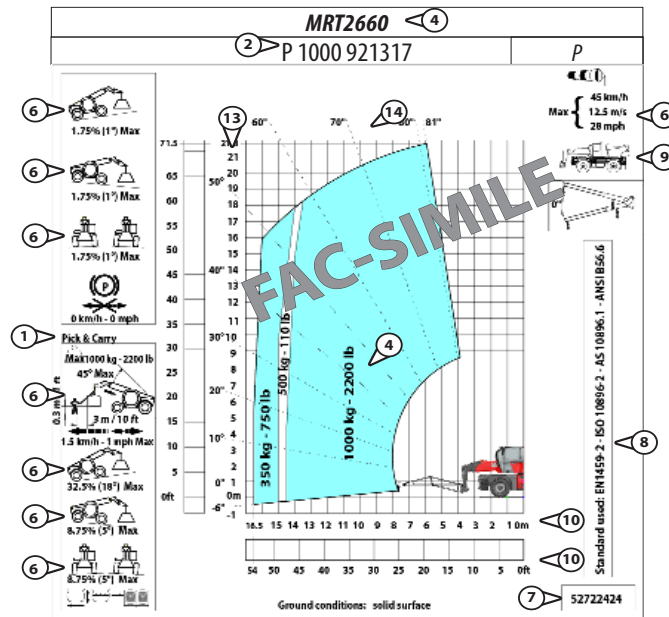

Riferimento	Indicazione (esempio)	Esempio
1	Tabella di portata (pick and carry)	
2	Tipo di macchina	MRT 2660+
3	Tipo di accessorio	P 1000
4	Capacità massima di carico dell accessorio gru in uso	1000kg
6	Condizioni di uso	-
7	Codice tabella di portata	52727404
8	Tabella di portata secondo norma	EN1459 - AS1418.19 - ASME B56.6
9	Configurazione di lavoro della macchina: su gomme	-
10	Sistema metrico [unità di lunghezza (m) e unità di peso (kg)] o sistema imperiale [unità di lunghezza (ft) e unità di peso (lb)]	-



IT

US

NL

LEGEND OF SIGNS AND SYMBOLS

OVERVIEW (Example):

	Warning ! be careful ! your safety or the safety of the lift truck is at risk.
--	--

CRANE ATTACHMENT TECHNICAL DATA

[kg] (lb)	[t] (t)	[mm] (in) x [m] (ft)	[m/min] (ft/min)	[bar] (psi)	[mm] (in)						[kg] (lb)
					A	B	C	D	E	F	
1 1200 (2204)	2 5 (5)	3 Ø 10 (0,4) x 30 (98)	4 46 (150)	5 200 (2900)	6 A: 750 (29) B: 117 (4) C: 734 (29) D: 2692 (106) E: 2980 (117) F: 586 (23)						7 360 (793)

Reference	Indication (example)
1	Maximum load of crane attachment [1200] (2204)
2	Maximum capacity of crane attachment hook [5] (5)
3	Rope diameter Ø [10] (0.4) X length [30] (98) of the rope of the crane attachment
4	Crane attachment rope ascent/descent maximum speed [46] (150)
5	Maximum operating pressure of crane attachment [200] (2900)
6	Dimensions of crane attachment [mm] (in) (referred to dimensional drawing)
7	Weight of crane attachment [360] (793)
8	Metric system [unit of length (mm, m), unit of speed (m/min) unit of pressure (bar) and unit of weight (kg, t)] or imperial system [unit of length (in, ft), unit of speed (ft/min), unit of pressure (psi) and unit of weight (lb, t)]

CRANE ATTACHMENT CAPACITY TABLE

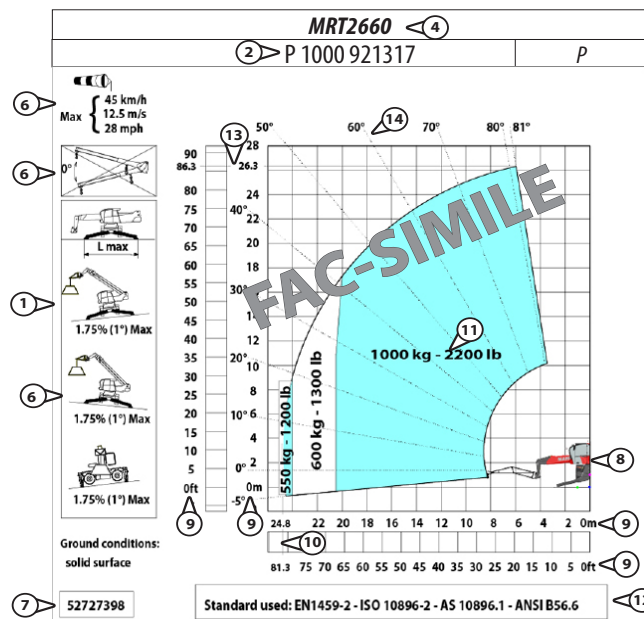

Reference	Indication (example)	Example
1	Capacity table	
2	Crane attachment type	P 1000
4	Machine model	MRT 2260 +
5	Machine in working configuration: on front tyres, on tyres and turret rotated, on stabilisers	
6	Working conditions	
7	Load table code	52727398
8	Indicative drawing of the machine	
9	Metric system [unit of length (m) and unit of weight (kg)] or imperial system [unit of length (ft) and unit of weight (lb)]	
10	Maximum length extension of the telescopic boom	24,8 m / 81.3 ft
11	Load capacity range of the machine	1000 kg / 2200 lb
12	Capacity table according to standards in force in the destination country	EN1459 - AS1418.19 - ASME B56.6
13	Maximum lift height of the telescopic boom	26,3 m / 86.3 ft
14	Angle of the boom	-5°, 0°, 10°, 20°, 30°, 40°, 50°, 60°, 70°, 80°



IT

US

NL

CRANE ATTACHMENT PICK AND CARRY TABLE

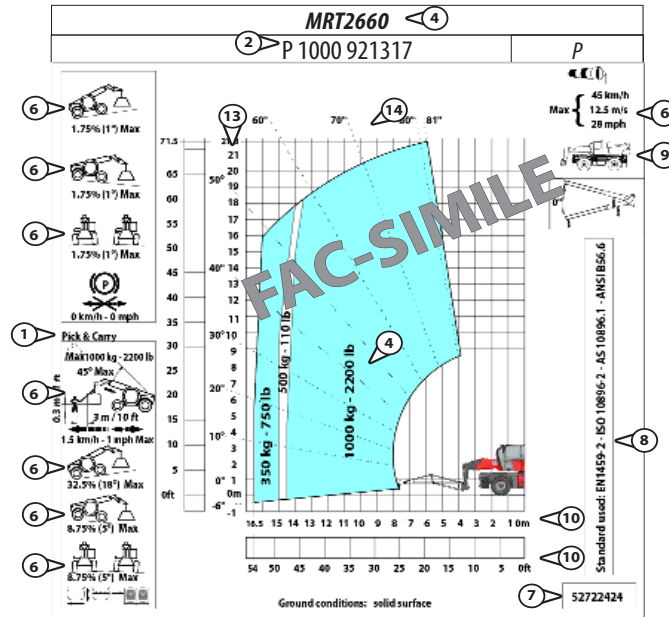

Reference	Indication (example)	Example
1	Load table (pick and carry)	
2	Machine type	MRT 2660+
3	Crane type	P 1000
4	Maximum load capacity of the crane	1000kg
6	Conditions of use	-
7	Load table code	52727404
8	Load table according to standard	EN1459 - AS1418.19 - ASME B56.6
9	Machine sketch in working configuration: on tires	-
10	Metric unit [length unit (m) and weight unit (kg)] or imperial unit [length unit (ft) and weight unit (lb)]	-

IT

US

NL

LEGENDE TEKENS EN SYMBOLEN

OVERZICHT (Voorbeeld):

	Let op! Wees voorzichtig! Uw veiligheid en de veiligheid van anderen en van de heftruck lopen gevaar.
--	---

TECHNISCHE GEGEVENS VAN HET KRAANWERKTOUIG

8	[kg] (lb)	[t] (t)	[mm] (in) x [m] (ft)	[m/min] (ft/min)	[bar] (psi)	[mm] (in)						[kg] (lb)
	1	2	3	4	5	A	B	C	D	E	F	7
	1200 (2204)	5 (5)	Ø 10 (0,4) x 30 (98)	46 (150)	200 (2900)	750 (29)	117 (4)	734 (29)	2692 (106)	2980 (117)	586 (23)	360 (793)

Referentie	Aanwijzing (voorbeeld)
1	Max. belasting van het kraanwerktuig [1200] (2204)
2	Max. draagvermogen van de haak van het kraanwerktuig [5] (5)
3	Diameter kabel Ø [10] (0,4) x lengte [30] (98) van de kabel van het kraanwerktuig
4	Max. snelheid stijgen/dalen van het kraanwerktuig [46] (150)
5	Max. bedrijfsdruk van het kraanwerktuig [200] (2900)
6	Afmetingen van het kraanwerktuig [mm] (in) (met betrekking tot de tekening met de afmetingen)
7	Massa van het kraanwerktuig [360] (793)
8	Metrisch stelsel [lengte-eenheid (mm, m), snelheidseenheid (m/min), drukeenheid (bar) en gewichtseenheid (kg, t)] of imperiaal stelsel [lengte-eenheid (in, ft), snelheidseenheid (ft/min), drukeenheid (psi) en gewichtseenheid (lb, t)]

DRAAGVERMOGENTABEL VAN HET KRAANWERKTOUIG

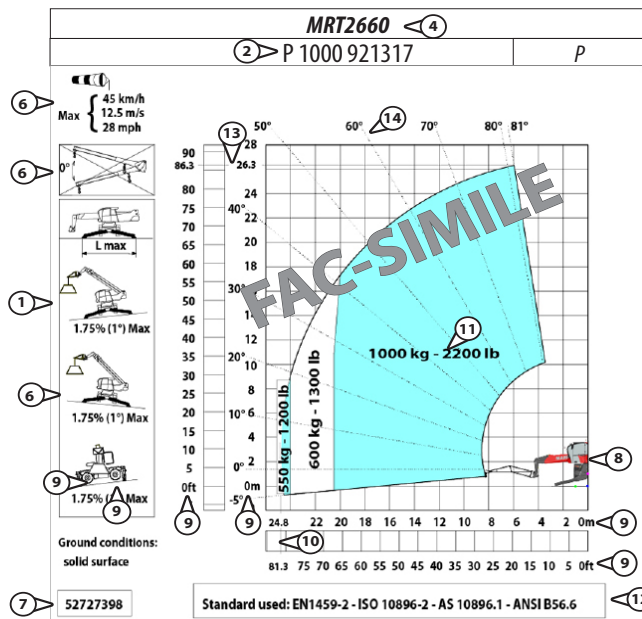

Referentie	Aanwijzing (voorbeeld)	Voorbeeld
1	Draagvermogen tabel	
2	Type kraanwerktuig	P 1000
4	Model machine	MRT 2260 +
5	Werkconfiguratie van de machine: op banden vooraan, op banden en gedraaide zwenkknop, op stabilisatoren	
6	Gebruiksvoorwaarden	
7	Code draagvermogen tabel	52727398
8	Identificatietekening van de machine	
9	Metrisch stelsel [lengte-eenheid (m) en gewichtseenheid (kg)] of imperiaal stelsel [lengte-eenheid (in) en gewichtseenheid (lb)]	
10	Max. lengte uitschuiven telescopische arm	24,8 m / 81.3 ft
11	Max. belasting van het gebruikte kraanwerktuig	1000 kg / 2200 lb
12	Draagvermogen tabel volgens de van kracht zijnde wetgeving in het land van bestemming	EN1459 - AS1418.19 - ASME B56.6
13	Max. hijs hoogte van de arm	26,3 m / 86.3 ft
14	Hoek van de arm	-5°, 0°, 10°, 20°, 30°, 40°, 50°, 60°, 70°, 80°

IT

US

NL

TABEL KRAANWERKTUIG "PICK AND CARRY"

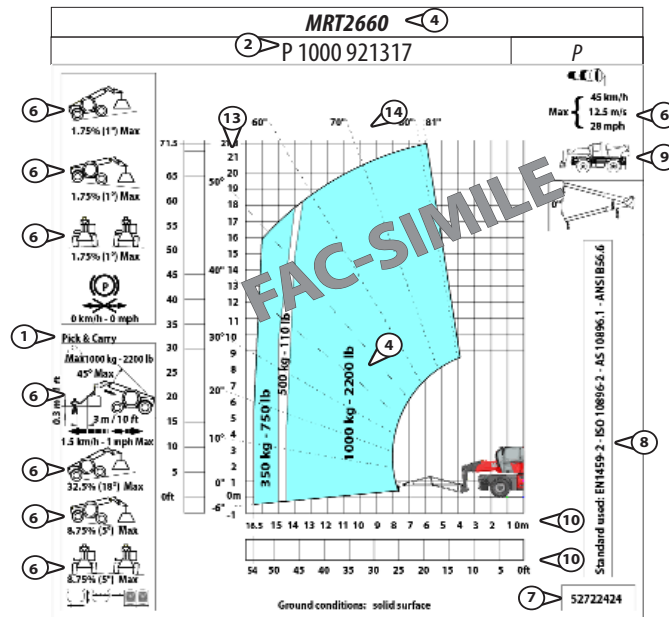

Referentie	Aanwijzing (voorbeeld)	Voorbeeld
1	Draagvermogen tabel (pick and carry)	
2	Type machine	MRT 2660+
3	Type werktuig	P 1000
4	Max. belasting van het gebruikte kraanwerktuig	1000kg
6	Gebruiksvoorwaarden	-
7	Code draagvermogen tabel	52727404
8	Draagvermogen tabel volgens de norm	EN1459 - AS1418.19 - ASME B56.6
9	Werkconfiguratie van de machine: op banden	-
10	Metrisch stelsel [lengte-eenheid (m) en gewichtseenheid (kg)] of imperiaal stelsel [lengte-eenheid (in) en gewichtseenheid (lb)]	-



1 - SICUREZZA

SAFETY

VEILIGHEID





IT

INTRODUZIONE

Il costruttore mette a vostra disposizione (con garanzia) una vasta gamma di accessori per il vostro carrello elevatore e ad esso perfettamente adattati.

Gli accessori sono consegnati con un diagramma di carico relativo al vostro carrello elevatore. Il libretto d'istruzioni e il diagramma di carico dovranno rimanere nel carrello elevatore. L'uso dei possibili accessori è regolato dalle istruzioni contenute nel presente manuale.

Quando l'accessorio montato prevede il sollevamento di carichi sospesi (es. jib con gancio, argano etc...) il vostro carrello elevatore viene classificato automaticamente come gru mobile



Solo gli accessori omologati e certificati "CE" dal costruttore sono utilizzabili sui nostri carrelli elevatori. La responsabilità del costruttore non sarà coinvolta in caso di modifica o utilizzazione di accessori effettuata a sua insaputa.



È vietato l'uso di accessori intercambiabili non previsti in origine in dotazione sulla macchina.

Nel caso di successive richieste di implementazione delle funzioni della macchina con altri accessori, l'utente prima della messa in servizio ha l'obbligo di richiedere il controllo d'idoneità all'impiego da parte di un tecnico autorizzato MANITOU, che provvederà a verificare il corretto funzionamento e l'aggiornamento della documentazione necessaria all'uso del nuovo accessorio.

Solamente dopo tale controllo verrà rilasciato un nuovo certificato di conformità "CE" della macchina riportante unicamente i nuovi accessori installati.



Tutti gli accessori con braccio gru devono essere utilizzati in posizione orizzontale (vedi diagrammi di portata); per gli argani verificare la perfetta verticalità tramite l'indicatore a pendolo posto sul telaio dell'accessorio.



La macchina equipaggiata di accessorio con carico sospeso è conforme alle seguenti norme:

- DIN 15018-1, gruppo di sollevamento H1, gruppo di sollecitazione B3
- DIN 15019-2
- EN 13000/2004, velocità del vento inferiore a 50Km/h.

Gli argani sono progettati secondo la norma ISO 4301, con condizioni di impiego e classe dell'apparecchiatura: T4, L2, M4.

US

INTRODUCTION

The Manufacturer provides a large range of attachments (with guarantee) perfectly suitable for your forklift truck.

The attachments are delivered together with a load chart relative to your forklift truck. The instructions handbook and the load chart must remain inside the forklift truck. The use of possible attachments depends on the instructions given in this Manual.

When the attachment mounted involves lifting of suspended loads (for example, arm with hook, winch, etc...) your forklift truck is classified automatically as a mobile crane



Only type-approved attachments "CE" certified by the manufacturer can be used on our forklift trucks. The Manufacturer shall not accept responsibility in case of modifications or use of attachments without authorization.



Use of interchangeable attachments not originally included in the machine supply is forbidden.

In case of subsequent requests for implementation of machine functions with other attachments, before starting up the machine, the user must contact an authorized MANITOU technician to check the suitability for use, to check the correct working and update the documentation necessary for using the new attachment. It is only after this check that a new CE certificate of conformity of the vehicle will be issued indicating only the new attachments installed.



All the attachments with crane arm must be used in the horizontal position (see load diagrams); for the winches, check to ensure perfect verticality by means of a pendulum indicator placed on the attachment frame.



The machine fitted with attachment with suspended load conforms to the following standards:

- DIN 15018-1, H1 lifting unit, B3 stress unit
- DIN 15019-2
- EN 13000/2004, wind speed less than 50km/h.

The winches are designed in accordance with standard ISO 4301, with use condition and equipment class: T4, L2, M4.

NL

INLEIDING

De fabrikant stelt een breed assortiment werktuigen (onder garantie) tot uw beschikking welke speciaal zijn ontworpen voor uw heftruck.

De werktuigen worden geleverd met een laaddiagram aangepast aan uw heftruck. De handleiding en het laaddiagram moeten in de heftruck blijven. Het gebruik van de mogelijke werktuigen wordt geregeld door de voorschriften van deze handleiding.

Als het gemonteerde werktuig hangende lasten optilt (bijv. arm met haak, lier enz...) dan wordt uw heftruck automatisch als mobiele kraan geïdentificeerd



Uitsluitend de door de fabrikant goedgekeurde en "EG" gecertificeerde werktuigen mogen op onze heftrucks worden gebruikt. De fabrikant wijst iedere aansprakelijkheid van de hand in geval van zonder zijn medeweten uitgevoerde wijzigingen of gebruik van de werktuigen.



Het gebruik van verwisselbare werktuigen die oorspronkelijk niet bij de machine voorzien zijn is verboden.

In geval van verdere verzoeken om andere werktuigen aan de machine te koppelen om de functies ervan uit te breiden, dient de gebruiker voor de eerste ingebruikname aan een technicus van MANITOU te vragen of deze controleert of de machine geschikt is om gebruikt te worden. Deze technicus zal controleren of de machine correct werkt en of de nodige documentatie voor het gebruik van het nieuwe werktuig bijgewerkt is.

Pas na deze controle wordt een nieuwe "EG" verklaring van overeenstemming van de machine afgegeven met alleen de nieuw gemonteerde werktuigen.



Alle werktuigen met kraanarm moeten in horizontale stand gebruikt worden (zie laaddiagrammen); controleer bij de lieren de perfecte verticale stand met behulp van de slinger op het frame van het werktuig.



De machine met werktuig en hangende lading is in overeenstemming met de volgende normen:

- DIN 15018-1, optilgroep H1, belastingsgroep B3
- DIN 15019-2
- EN 13000/2004, windsnelheid lager dan 50 km/h.

De lieren zijn ontworpen volgens de norm ISO 4301, met gebruiksomstandigheden en klasse van de apparatuur: T4, L2, M4.



IT

CONSIGLI GENERALI RELATIVI ALL'UTILIZZO DELLA GRU

Quando vedete questo simbolo significa che:



Attenzione! Siate prudenti! E' in gioco la vostra sicurezza o quella della gru.



Prima di operare con la gru su pneumatici o su stabilizzatori verificare sempre la consistenza del suolo (controllare i dati sugli appoggi nel manuale di uso e manutenzione del "carrello elevatore"), nel caso in cui il suolo non sia adatto a sopportare il peso della gru, consultare vostro agente o concessionario per prendere le opportune precauzioni.

Attenersi ai dati indicati sui diagrammi di carico. In nessun caso tentare di sollevare carichi superiori a quelli ammessi sui diagrammi di carico allegati alla macchina.

Trasportare il carico a pochi centimetri dal suolo (30 cm max) con la minima estensione del braccio.

Guidare la gru ad una velocità adeguata alle condizioni e allo stato del terreno.

La velocità di spostamento del carrello elevatore non deve superare 0,4 m/s (1,5 km/h, ovvero un quarto della velocità di un pedone).

Durante lo spostamento, farsi aiutare da una persona a terra (posizionata almeno a 3 m dal carico) che, con l'aiuto di una barra di mantenimento o di una corda, limiti le oscillazioni del carico.

Senza carico applicato viaggiare con braccio telescopico abbassato e rientrato al massimo.

Non andare mai troppo forte né frenare bruscamente con un carico.

Quando il carico viene sollevato, fare attenzione che nessuno possa intralciare l'operazione e non compiere manovre errate. Non tentare di compiere operazioni che superino le capacità della gru.

Fare attenzione ai cavi elettrici.

Non utilizzare la gru durante forti temporali ed in presenza di rischio caduta fulmini.

Non lasciare in nessun caso il carrello in parcheggio con un carico sollevato.

Non avvicinarsi ed entrare nel raggio di azione della gru.

Pensare sempre alla sicurezza e trasportare solamente dei carichi ben equilibrati.

US

GENERAL RECOMMENDATIONS REGARDING THE USE OF THE CRANE

Whenever you see this symbol it means:



Warning! Be careful! Your safety and that of the crane is at stake.



Before working with the crane on wheels or stabilizers, always check the consistency of the ground (check the data regarding supports in the forklift truck Operation and Maintenance Manual); if the ground is unsuitable for the weight of the crane, consult your agent or dealer to adopt appropriate precautionary measures.

Strictly follow the data indicated on the load charts. Never attempt to lift loads greater than those permitted as indicated in the load diagrams attached to the machine.

Carry the load a few centimetres above the ground (max. 30 cm) the shortest possible jib length.

Drive the crane at a speed suitable for the conditions and state of the ground.

The lift truck must not travel at more than 0.4 m/s (1.5 km/h, i.e., one quarter walking speed).

During transport, the lift truck operator must be assisted by a person on the ground (standing a minimum of 3 m from the load), who will limit swinging of the load using a bar or a rope.

Without load, travel with the telescopic boom lowered and retracted to the maximum possible extent.

Never travel too fast or brake suddenly when travelling with load.

When the load is being lifted, make sure no one can obstruct the operation or make incorrect manoeuvres. Do not try to carry out operations which exceed the crane capacity.

Pay attention to the electric cables.

Do not use the crane during heavy thunderstorms and when there is risk of lightning.

Never leave the forklift truck parked with a load raised.

Never approach or go within the range of action of the crane.

Always bear safety in mind and only transport loads that are balanced properly.

NL

ALGEMENE RAADGEVINGEN MET BETREKKING TOT DE KRAAN

Als u dit symbool ziet, wil dat zeggen:



Let op! Wees voorzichtig! Uw eigen veiligheid of die van de kraan staat op het spel.



Voor de kraan op banden of op stabilisatoren te gebruiken moet altijd de gesteldheid van de grond nagekeken worden (controleer de gegevens over de steun in de handleiding voor gebruik en onderhoud van de "heftruck"), als de grond niet geschikt mocht zijn om het gewicht van de kraan te dragen, raadpleeg dan uw agent of dealer voor de nodige maatregelen.

Neem de gegevens in de laaddiagrammen in acht. Probeer in geen geval lasten op te tillen die zwaarder zijn dan het toegestane gewicht dat vermeld is op het laaddiagram dat bij de machine is gevoegd.

Verplaats de last op een paar centimeter van de grond (max. 30 cm) met een minimaal uitgestrekte arm.

Rijd met een snelheid die geschikt is voor de toestand en de staat van het terrein.

De heftruck mag niet sneller rijden dan 0,4 m/s (1,5 km/h, dit is vier keer trager dan een voetganger).

Laat u tijdens het verplaatsen bijstaan door een persoon op de grond (die zich op ten minste 3 m van de last bevindt) die, met behulp van een staaf of een touw het schommelen van de last beperkt.

Zonder lading, rijden met de telescopische arm naar beneden en zo ver mogelijk ingetrokken.

Nooit te hard rijden of plotseling remmen als men een lading vervoert.

Als de last wordt opgetild, opletten dat niemand de werkzaamheden kan belemmeren en geen verkeerde bewegingen maken. Niet proberen handelingen te verrichten die het vermogen van de kraan te boven gaan.

Opletten in de buurt van elektriciteitskabels.

Gebruik de kraan niet tijdens heftig onweer en als er gevaar voor bliksem heerst.

Parkeer nooit de heftruck met opgeheven lading.

Kom niet in de buurt van de kraan, binnen de werkstraal.

Altijd de veiligheid in gedachten houden en uitsluitend goed uitgebalanceerde ladingen vervoeren.



IT

Non lasciare la gru carica con il freno di stazionamento inserito su una pendenza superiore al 15%.

La gru ammette queste inclinazioni di lavoro:

- Macchina stabilizzata:
 - 1° Max in senso longitudinale
 - 1° Max in senso trasversale.
- Macchina su gomme:
 - 1° Max in senso longitudinale
 - 1° Max in senso trasversale.

Con argano o attrezzature con carico appeso al gancio è necessario:

- posizionare l'argano perpendicolarmente al carico da sollevare,
- la discesa del gancio a vuoto, deve essere avviata lentamente (dolcemente) poiché se azionata velocemente può allentare la fune attorcigliata sul tamburo, con gravi guai per la fune stessa, il fine corsa, etc..
- Se la fune, sul bozzello tende ad avvitarci, sganciare il gancio capocorda fisso, tirare la fune e ruotarla nel senso opposto fino ad annullare l'avvitamento, quindi riagganciare il capocorda.
- Manovrare con dolcezza la leva di comando per evitare sobbalzi del carico ed eventuali difettosi avvolgimenti della fune sul tamburo.
- Sollevare il carico verticalmente, evitando oscillazioni e sollevamenti obliqui.
- Verificare giornalmente lo stato della fune, se usurata, rovinata o anche solamente con un filo rotto (vedi ISO 4309), provvedere immediatamente alla sostituzione (consultare il vostro concessionario).
- Verificare giornalmente l'efficienza del fine corsa idraulico salita e discesa gancio e la tenuta del freno con carico applicato.
- Prestare attenzione agli accessori usati per sollevare il carico: in particolare controllare la capacità in relazione alla portata massima della gru e verificarne periodicamente l'integrità.
- Lubrificare periodicamente con olio la parte rotante del gancio.
- Verificare periodicamente il buon avvolgimento della fune sul tamburo.

Gli accessori seguenti non sono destinati ad impianti per il sollevamento o lo spostamento di persone.

Prima della prima messa in servizio dell'argano, o di qualsiasi altra attrezzatura che appenda il carico con un gancio, denunciarlo alla autorità preposta per il controllo (ISPEL) della vostra zona (solo per Italia). Ricordarsi ogni anno seguente di richiedere la visita di controllo alla USL della vostra zona (solo per Italia).

US

Do not leave the crane loaded with the parking brake engaged on a slope exceeding 15%.

The following operating inclinations are allowed for the crane:

- Vehicle stabilised:
 - 1° Max longitudinally
 - 1° Max transversely.
- Vehicle on wheels
 - 1° Max longitudinally
 - 1° Max transversely.

With the winch or with the attachment with load hanging from the hook:

- position the winch perpendicular to the load to be lifted,
- the hook without load must be lowered gently because if it moves too fast, it could slacken the rope wound around the drum, causing damage to the rope, limit switch, etc..
- If the rope tends to start twisting on the pulley block, release the fixed rope connector hook, pull the rope and turn it in the opposite direction to undo the twist, then re-hook the connector.
- Operate the control lever gently to avoid jerking at the load and defective winding of the rope on the drum.
- Lift the load vertically, avoiding oscillations and oblique lifting.
- Check the condition of the rope everyday, and if worn, damaged or even one of the strands is broken (see ISO4309), replace it immediately (consult your dealer).
- Check the working efficiency of the hook ascent/descent hydraulic limit switch and the brake hold with the load applied, on a daily basis.
- Pay attention to the attachments used for lifting the load: in particular, check the capacity in relation to the maximum crane capacity and check its condition periodically.
- Lubricate the rotating part of the hook periodically with oil.
- Check periodically to make sure the rope is wound properly on the drum.

The following attachments are not meant for systems used for lifting or transporting persons.

Before starting operation with the winch, or any other equipment on which the load is hung by a hook, notify the relevant authorities in your area (ISPEL) (for Italy only). Remember to contact the LHU of your area for an inspection every year (for Italy only).

NL

Nooit een geladen kraan met aangetrokken handrem laten staan op een helling van meer dan 15%.

Voor de kraan zijn de volgende hellingshoeken toegestaan:

- Stabiele machine:
 - 1° Max in de lengte
 - 1° Max in de breedte.
- Machine op banden:
 - 1° Max in de lengte
 - 1° Max in de breedte.

Met de lier of werktuigen met een lading aan de haak moet u:

- de lier loodrecht op de op te tillen last plaatsen,
- de lege haak moet langzaam beginnen te dalen (soepel) want als dit snel wordt gedaan kan de op de trommel gewikkelde kabel verslappen, met ernstige gevolgen voor de kabel zelf, de eindaanslag, enz.
- Als de kabel op de takel neigt vast te draaien, de haak van het vaste uiteinde losmaken, aan de kabel trekken en hem in tegengestelde richting draaien totdat hij losgedraaid is, dan het kabeluiteinde weer vastmaken.
- Bedien de bedieningshendel voorzichtig om de lading niet te laten opspringen en te vermijden de kabel niet goed op de trommel te winden.
- Til de lading verticaal op, zonder oscillaties en niet scheef opheffen.
- Controleer dagelijks de staat van de kabel, als hij versleten of beschadigd is of zelfs maar een kapotte draad mocht hebben (zie ISO 4309), hem onmiddellijk vervangen (raadpleeg uw dealer).
- Controleer dagelijks de doeltreffendheid van de hydraulische eindaanslag voor het stijgen en dalen van de haak en de remwerking met toegepaste lading.
- Let op de werktuigen die gebruikt worden om de lading op te tillen: controleer in het bijzonder het vermogen in verhouding tot het maximale hefvermogen van de kraan en kijk ze regelmatig na.
- Smeer regelmatig het draaiende deel van de haak met olie.
- Controleer regelmatig de opwikkeling van de kabel op de trommel.

- De volgende werktuigen zijn niet bestemd voor het optillen of het vervoer van personen.

Voor de lier, of een ander werktuig dat de last met een haak optilt, in gebruik wordt genomen, gelieve dit te melden aan de plaatselijke instantie die belast is met de controle (alleen voor Italië).

- Niet vergeten ieder jaar de bevoegde ASL te verzoeken een controle te verrichten (uitsluitend in Italië).



IT



Prima della messa in servizio della gru accertarsi della compatibilità della macchina e della taratura del suo sistema di sicurezza al tipo di accessorio montato.



Una taratura non conforme del sistema di sicurezza può risultare molto pericolosa per la vostra sicurezza, se avete dubbi non esitate, consultate immediatamente il vostro concessionario.



Alcuni accessori, tenuto conto delle loro dimensioni, e con il braccio abbassato e rientrato, rischiano di interferire con i pneumatici anteriori e di provocare il loro deterioramento se l'inclinazione dell'attrezzatura è rivolta in basso.

Per eliminare tale rischio, far uscire il braccio telescopico di una lunghezza sufficiente in funzione dell'accessorio, in modo tale che non avvengano interferenze.



I carichi massimi sono definiti dalla capacità della gru, tenuto conto del peso e del centro di gravità dell'accessorio. Qualora l'accessorio avesse una capacità inferiore a quella della gru, non superare mai questo limite.



Per la vostra sicurezza, considerato che i carichi da sollevare nella maggior parte dei casi non possono essere collegati direttamente al gancio della macchina, è consigliato l'uso di sistemi di imbracatura, come funi di acciaio, catene, fasce di fibre sintetiche o naturali conformemente alle normative vigenti.

US



Before starting up the crane ensure the compatibility of the machine and the calibration of its safety system to the type of attachment fitted.



Non conforming calibration of the safety system can be very hazardous for your safety; contact your dealer immediately in case of doubt.



Given their dimensions, certain attachments, with the boom lowered and retracted, risk interfering with the front tyres and causing their deterioration if the equipment is inclined downwards.

To eliminate this risk, extend the telescopic boom to a sufficient length depending on the function of the attachment, in such a way as to avoid interference.



The maximum loads are defined by the capacity of the crane, taking into account the weight and centre of gravity of the attachment. If the capacity of the attachment is less than that of the crane, never exceed this limit.



Considering that in most cases the loads to be lifted cannot be connected directly to the machine hook, for your safety we recommend the use of harnessing systems such as steel ropes, chains, straps made of synthetic or natural fibres conforming to the regulatory standards in force.

NL



Alvorens de kraan te gebruiken, controleren of de machine en de afstelling van zijn veiligheidssysteem en het type gemonteerde werktuig goed op elkaar zijn afgestemd.



Een afstelling die niet conform het veiligheidssysteem is kan uw veiligheid in het gedrang brengen. Neem in geval van twijfel onmiddellijk contact op met uw dealer.



Bepaalde werktuigen kunnen, gezien hun afmetingen, in aanraking komen met de banden als de arm naar beneden gehaald en ingetrokken is en deze beschadigen als het werktuig naar beneden overhelt.

Om dit risico te voorkomen, de telescopische arm zo ver uitschuiven als nodig is, afhankelijk van het werktuig, om ervoor te zorgen dat er geen aanraking mogelijk is.



De maximale belastingen worden bepaald door het draagvermogen van de kraan, rekening houdend met het gewicht en het zwaartepunt van het werktuig. In het geval het werktuig een kleiner draagvermogen heeft dan de kraan, deze limiet nooit overschrijden.



Voor uw eigen veiligheid, gezien het feit dat de op te tillen lading in de meeste gevallen niet direct aan de haak van de machine bevestigd kan worden, wordt het gebruik van vasbindsystemen aangeraden, zoals bijvoorbeeld staalkabels, kettingen, riemen van synthetische of natuurlijke vezels in overeenstemming met de geldende normen.



IT

US

NL



Assicurarsi che la velocità del vento non superi i 36 km/h.

Per riconoscere visivamente questa velocità consultare la scala di valutazione empirica dei venti riportate di seguito:

Scala BEAUFORT (velocità del vento ad un'altezza di 10 m su un terreno pianeggiante)						
Grado	Tipo di vento	Velocità (nodi)	Velocità (km/h)	Velocità (m/s)	Effetti a terra	Stato del mare
0	Calma	0 - 1	0 - 1	< 0,3	Il fumo sale verticalmente.	Mare piatto.
1	Bava di vento	1 - 3	1 - 5	0,3 - 1,5	Il fumo indica la direzione del vento.	Leggere increspature sulla superficie somiglianti a squame di pesce.
2	Brezza leggera	4 - 6	6 - 11	1,6 - 3,3	Si sente il vento sulla faccia, le foglie si muovono.	Onde minute, ancora molto corte ma ben evidenziate.
3	Brezza tesa	7 - 10	12 - 19	3,4 - 5,4	Foglie e rami più piccoli in movimento costante.	Onde con creste che cominciano a rompersi.
4	Vento moderato	11 - 16	20 - 28	5,5 - 7,9	Il vento solleva polvere e carta. I rami sono agitati.	Onde con tendenza ad allungarsi. Le "pecorelle" sono più frequenti.
5	Vento teso	17 - 21	29 - 38	8 - 10,7	Oscillano gli arbusti con foglie.	Onde moderate dalla forma che si allunga.
6	Vento fresco	22 - 27	39 - 49	10,8 - 13,8	Movimento di grossi rami, i fili metallici fischiano. Difficoltà ad usare l'ombrello.	Onde grosse (cavalloni) dalle creste imbiancate di schiuma e spruzzi.
7	Vento forte	28 - 33	50 - 61	13,9 - 17,1	Interi alberi agitati. Difficoltà a camminare contro vento.	I cavalloni si ingrossano. La schiuma formata dal rompersi delle onde viene "soffiata" in strisce nella direzione del vento.
8	Burrasca	34 - 40	62 - 74	17,2 - 20,7	Ramoscelli strappati dagli alberi. È molto difficile camminare contro vento.	Onde alte e di maggiore lunghezza, le creste si rompono e formano spruzzi vorticosi.
9	Burrasca forte	41 - 47	75 - 88	20,8 - 24,4	Il vento causa danni alle strutture (camini e tegole asportati, ecc.).	Onde alte con le creste che iniziano ad arrotolarsi, strisce di schiuma, visibilità ridotta.
10	Tempesta	48 - 55	89 - 102	24,5 - 28,4	Rara in terraferma. Sradicamento di alberi. Considerevoli danni strutturali.	Onde molto alte, le strisce di schiuma tendono a compattarsi e la visibilità è ridotta.
11	Tempesta violenta o fortunale	56 - 63	103 - 117	28,5 - 32,6	Molto rara, vasti danni strutturali.	Onde enormi che potrebbero anche nascondere alla vista navi di media stazza, visibilità ridotta.
12	Uragano	64 +	118 +	32,7 +	Onde altissime.	Mare completamente bianco, aria piena di schiuma e di spruzzi, visibilità estremamente ridotta.



IT

US

NL



Ensure that the wind speed is not higher than 36 km/h - 10 m/s (22.3 mph - 32.8 ft/s).

To visually recognise this wind speed, refer to the empirical wind evaluation scale below:

BEAUFORT scale (wind speed at a height of 10 m on a flat site)						
Force	Type of wind	Speed (knots)	Speed (km/h)	Speed (m/s)	Effects on Land	Sea conditions
0	Calm	0 - 1	0 - 1	< 0,3	Smoke rises vertically.	Sea is like a mirror.
1	Light air	1 - 3	1 - 5	0,3 - 1,5	Smoke indicates direction of wind.	Ripples with appearance of scale, no foam crests.
2	Light breeze	4 - 6	6 - 11	1,6 - 3,3	Wind felt on face, leaves rustle.	Short wavelets, but pronounced.
3	Gentle breeze	7 - 10	12 - 19	3,4 - 5,4	Leaves and small twigs in constant motion.	Very small waves, crests begin to break.
4	Moderate breeze	11 - 16	20 - 28	5,5 - 7,9	Wind raises dust and loose pieces of paper; small branches are moved.	Small waves, becoming longer, numerous whitecaps.
5	Fresh breeze	17 - 21	29 - 38	8 - 10,7	Small trees in leaf begin to sway.	Wavelets form on inland waters; moderate waves, taking longer form.
6	Strong breeze	22 - 27	39 - 49	10,8 - 13,8	Large branches in motion, whistling heard in overhead wires, umbrella use becomes difficult.	Larger waves forming, whitecaps everywhere, some spray.
7	Near gale	28 - 33	50 - 61	13,9 - 17,1	Whole trees in motion, inconvenience felt when walking against the wind.	Sea heaps up; white foam from breaking waves begins to be blown in streaks along the direction of the wind.
8	Gale	34 - 40	62 - 74	17,2 - 20,7	Wind breaks twigs off trees; impedes progress.	Moderately high waves of greater length; edges of crests begin to break into spindrift.
9	Strong gale	41 - 47	75 - 88	20,8 - 24,4	Wind damages roofs (chimneys, slates, etc.).	High waves, crests of waves begin to topple, streaks of foam; reduced visibility.
10	Storm	48 - 55	89 - 102	24,5 - 28,4	Seldom experienced inland; trees uprooted; considerable structural damage occurs.	Very high waves; white streaks of foam; reduced visibility.
11	Violent storm	56 - 63	103 - 117	28,5 - 32,6	Very rare, widespread damage.	Exceptionally high waves able to hide medium sized ships from view, reduced visibility.
12	Hurricane	64 +	118 +	32,7 +	Devastating damage.	Sea completely white; air filled with foam and spray, very reduced visibility.



Controleer tijdens de werken voortdurend of de windsnelheid niet hoger is dan 36 km/u.

Om deze snelheid met het oog te herkennen, raadpleeg de onderstaande empirische inschattingsschaal:

Schaal van BEAUFORT (windsnelheid op 10 m boven een vlakke ondergrond)						
Kracht	Benaming	Snelheid (knopen)	Snelheid (km/h)	Snelheid (m/s)	Uitwerking boven land	Uitwerking boven zee
0	Stil	0 - 1	0 - 1	< 0,3	Rook stijgt recht omhoog.	Gladde zee.
1	Zeer zwak	1 - 3	1 - 5	0,3 - 1,5	De rook geeft de windrichting aan.	Kleine golfjes op het wateroppervlak die eruitzien als visschubben.
2	Zwakke wind	4 - 6	6 - 11	1,6 - 3,3	De wind is voelbaar in het gezicht, de bladeren bewegen.	Klein, korte golven die duidelijk waarneembaar zijn.
3	Vrij matige wind	7 - 10	12 - 19	3,4 - 5,4	Bladeren en kleine takken bewegen voortdurend.	Golven met schuimkoppen die beginnen te breken.
4	Matige wind	11 - 16	20 - 28	5,5 - 7,9	Papier en stof waaien op. Takken bewegen heen en weer.	De golven worden iets langer. Er zijn veel schuimkoppen.
5	Vrij krachtige wind	17 - 21	29 - 38	8 - 10,7	Struiken met bladeren ruisen.	Matige golven met langer wordende vorm.
6	Krachtige wind	22 - 27	39 - 49	10,8 - 13,8	Dikke takken bewegen, metalen draden maken lawaai. Een paraplu gebruiken wordt problematisch.	Grote golven met witte schuimkoppen.
7	Harde wind	28 - 33	50 - 61	13,9 - 17,1	Hele bomen bewegen. Tegen de wind inlopen is lastig.	De golven worden hoger. Het schuim dat gevormd wordt door het breken van de golven wordt in strepen in de richting van de wind "geblazen".
8	Stormachtige wind	34 - 40	62 - 74	17,2 - 20,7	Twijgen breken af. Tegen de wind inlopen wordt zeer moeilijk.	Hoge en langere golven, de koppen breken en vormen schuimvlagen.
9	Storm	41 - 47	75 - 88	20,8 - 24,4	De wind veroorzaakt schade aan gebouwen (schoorstenen en dakpannen waaien weg enz.).	Hoge golven met koppen die beginnen te rollen, schuimstrepen, beperkte zichtbaarheid.
10	Zware storm	48 - 55	89 - 102	24,5 - 28,4	Zeldzaam op het vasteland. Bomen worden ontworteld. Aanzienlijke schade aan gebouwen.	Heel hoge golven, de schuimstrepen vormen een schuimvlakte, beperkte zichtbaarheid.
11	Zeer zware storm of orkaanachtige wind	56 - 63	103 - 117	28,5 - 32,6	Zeer zeldzaam. grote schaden aan gebouwen.	Enorme golven die schepen van middelgrote afmetingen aan het oog kunnen onttrekken, beperkte zichtbaarheid.
12	Orkaan	64 +	118 +	32,7 +	Heel hoge golven.	De zee is volkomen wit, de lucht is vol met verwaaid schuim en water, sterk verminderd zicht.

IT

RICONOSCIMENTO AUTOMATICO DELL'ACCESSORIO "E-RECO"

La macchina è equipaggiata con un sistema elettronico di riconoscimento accessorio che identifica al momento dell'aggancio il tipo di accessorio installato.

Questo sistema facilita e velocizza le operazioni di cambio accessorio.

Il sistema è caratterizzato da 2 dispositivi situati uno sul braccio della macchina (rif.1a Fig. A) e uno sull'accessorio (rif.1b Fig. A).

Il sistema di riconoscimento, dopo l'identificazione del tipo di accessorio e la conferma dell'operatore, imposta la macchina per operare con l'accessorio agganciato. Questa modalità è definita automatica.

Tuttavia la macchina può operare con un accessorio privo di dispositivo di identificazione ma in questo caso è responsabilità dell'operatore identificare e confermare il tipo di accessorio agganciato. Questa modalità è definita manuale.

US

AUTOMATIC IDENTIFICATION OF THE ATTACHMENT "E-RECO"

The vehicle is equipped with an electronic attachment identification system which identifies the type of attachment connected.

This system makes the attachment change operations easier and faster.

The system is characterised by 2 devices, one on the (Ref.1a Fig. A) vehicle boom and the other on the attachment (Ref.1b Fig. A).

After identification of the type of attachment and confirmation by the operator, the identification system sets the vehicle to operate with the attachment connected. This mode is defined as automatic.

However, the vehicle can operate with an attachment devoid of the identification device, but in this case it is the operator's responsibility to identify and confirm the type of attachment connected. This mode is defined as manual.

NL

AUTOMATISCHE HERKENNING VAN HET WERKTUIG "E-RECO"

De machine is uitgerust met een elektronisch herkenningssysteem dat het type werktuig herkent wanneer het aangekoppeld wordt.

Dit systeem vergemakkelijkt en versnelt de procedure voor het verwisselen van het werktuig.

Het systeem wordt gekenmerkt door 2 elementen, één op de arm van de machine (ref. 1a Fig. A) en één op het werktuig (ref. 1b Fig. A).

Na de herkenning van het type werktuig en de bevestiging van de bestuurder, stelt het herkenningssysteem de machine in om met het aangekoppelde werktuig te werken. Dit is de automatische modaliteit.

De machine kan evenwel ook met een werktuig zonder het herkenningssysteem werken. In dit geval is de bestuurder verantwoordelijk voor het identificeren van het aangekoppelde werktuig en de bevestiging ervan. Dit is de handmatige modaliteit.

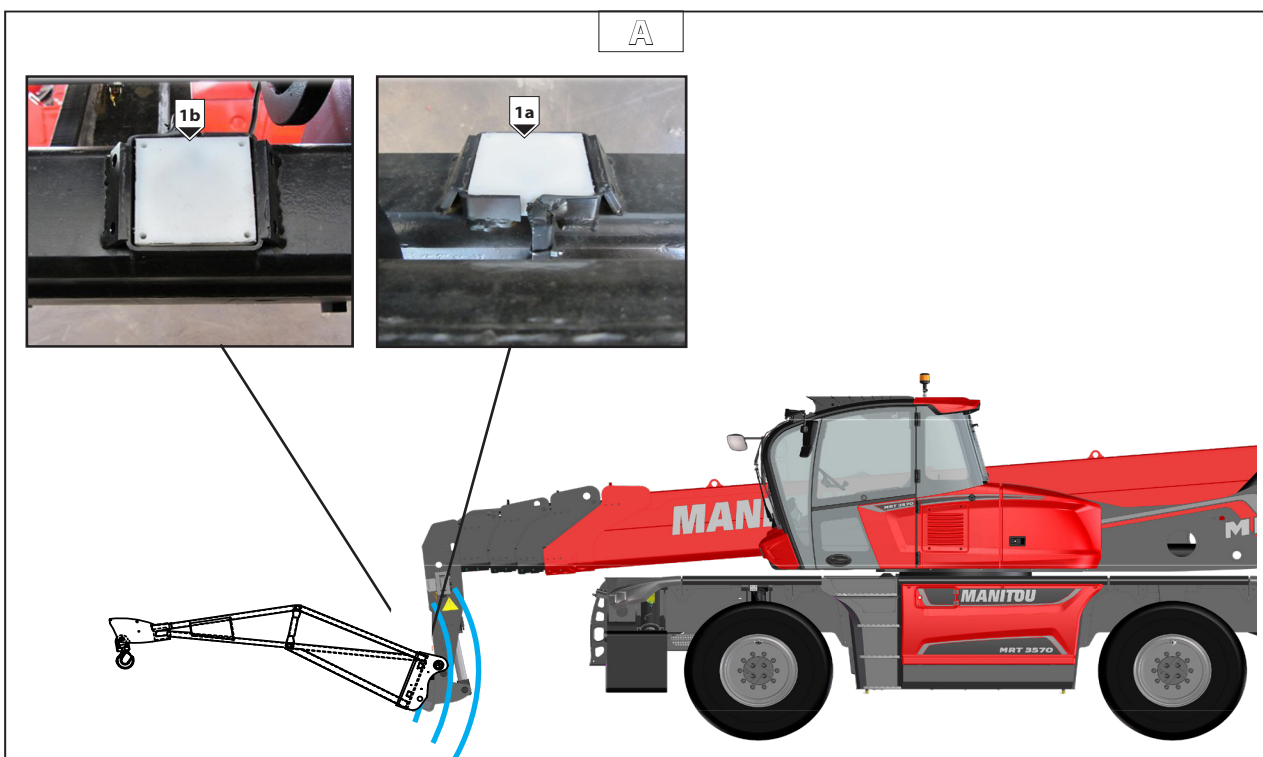



IT

Modalità automatica

Immediatamente dopo aver agganciato un accessorio il sistema di riconoscimento:

- Identifica il tipo di accessorio (1).
- Richiede all'Operatore di confermare che l'accessorio riconosciuto sia quello realmente agganciato sulla macchina.
- Premere il selettore a manopola (2) per confermare il tipo di accessorio.

Modalità manuale

Immediatamente dopo aver agganciato un accessorio privo del dispositivo di identificazione, il sistema di riconoscimento:

- non riconosce l'accessorio agganciato,
- l'Operatore deve selezionare il tipo di accessorio agganciato sulla macchina. L'operatore deve selezionare manualmente il tipo di accessorio installato, come segue:
- Premere il pulsante (3) per uscire dalla modalità "empty" [nessun accessorio agganciato],
- Ruotare la manopola (2) per selezionare l'accessorio che si è agganciato.
- Premere il selettore a manopola (2) per confermare il tipo di accessorio.

Nota: in modalità "empty" la macchina può muovere il braccio ma con una portata massima di sollevamento fissata a 500kg.

In entrambe le modalità:

è responsabilità dell'operatore assicurarsi che l'accessorio agganciato e visualizzato sul display sia quello identificato dal sistema di riconoscimento o selezionato manualmente.

Sono in gioco la vostra sicurezza e quella del carrello elevatore.

L'inosservanza potrebbe provocare malfunzionamenti al vostro carrello elevatore e danni a cose e persone vicine all'area di lavoro della macchina.

Rispettare le procedure sopra descritte.

US

Automatic mode

Immediately after connecting the attachment, the identification system:

- Identifies the type of attachment (1).
- Requests the Operator to confirm that the attachment identified is that actually connected on the vehicle.
- Press knob selector (2) to confirm the type of attachment.

Manual mode

Immediately after an attachment devoid of identification device is hooked up, the identification system:

- does not recognise the attachment connected,
- the Operator must select the type of attachment hooked on the vehicle. The operator must manually select the type of attachment installed, as follows:
- Press button (3) to exit the "empty" mode [no attachment connected],
- Turn the knob (2) to select the attachment that is connected.
- Press knob selector (2) to confirm the type of attachment.

Note: in "empty" mode the vehicle can move the boom but with a maximum lifting capacity fixed at 500 kg.

In both modes:

it is the operator's responsibility to make sure the attachment is connected and that the display shows the attachment identified by the identification system or selected manually.

Your safety and that of the forklift truck is at stake.

Failure to observe these indications can cause an operating fault in your forklift truck and harm to persons or damage to objects near the machine's operating area.

Follow the procedures described above.

NL

Automatische modaliteit

Onmiddellijk nadat u een werktuig heeft aangekoppeld, gaat het herkenningssysteem als volgt te werk:

- Herkenning van het type werktuig (1).
- Het verzoekt te bestuurder om te bevestigen dat het herkende werktuig daadwerkelijk aan de machine gekoppeld is.
- Druk op de keuzeschakelaar met knop (2) om het type werktuig te bevestigen.

Handmatige modaliteit

Onmiddellijk nadat u een werktuig zonder identificatiesysteem heeft aangekoppeld, gaat het herkenningssysteem als volgt te werk:

- het herkent het aangekoppelde werktuig niet,
- de bestuurder moet het type werktuig dat aan de machine gekoppeld is selecteren. De bestuurder moet het type werktuig dat aan de machine gekoppeld is handmatig selecteren:
- Druk op (3) om de modaliteit "empty" te verlaten [geen werktuig aangekoppeld].
- Draai aan de knop (2) om het werktuig dat is aangekoppeld te selecteren.
- Druk op de keuzeschakelaar met knop (2) om het type werktuig te bevestigen.

Opmerking; in de modaliteit "empty" kan de machine de arm bewegen, doch met een maximaal hefvermogen van 500 kg.

Voor beide modaliteiten:

is de bestuurder er verantwoordelijk voor te controleren of het aangekoppelde werktuig dat op het display wordt weergegeven hetzelfde is als datgene wat door het herkenningssysteem herkend wordt of met de hand geselecteerd is. Uw eigen veiligheid en die van de heftruck staan op het spel.

Het niet in acht nemen kan storingen aan de heftruck veroorzaken, schade aan voorwerpen en letsels aan personen die zich in de buurt van het werkgebied van de machine bevinden.

Volg de bovenstaande procedures.



IT

MONTAGGIO DELL'ACCESSORIO CON BLOCCO MANUALE

Presca dell'accessorio

- Verificare che l'accessorio sia in una posizione che faciliti l'aggancio dell'attacco rapido. Nel caso in cui fosse male orientato, prendete le precauzioni necessarie per spostarlo in condizioni di massima sicurezza.
- Verificare che il perno di bloccaggio sia inserito nell'apposito supporto sul telaio.
- Posizionare il carrello elevatore con il braccio abbassato ben di fronte e parallelo all'accessorio e inclinare l'attacco rapido in avanti (Fig.A).
- Portare l'attacco rapido sotto il tubo d'aggancio dell'accessorio, alzare leggermente il braccio e inclinare l'attacco stesso all'indietro per posizionare l'accessorio (Fig.B).
- Disimpegnare l'accessorio dal suolo per agevolare il bloccaggio.
- Confermare il riconoscimento dell'accessorio* a display (1, Fig. D).

Bloccaggio manuale

Prendere il perno di bloccaggio sul supporto e infilarlo nel foro dell'attacco rapido per bloccare l'accessorio (Fig. C). Non dimenticare di mettere la copiglia.

Sbloccaggio manuale

Procedere in senso inverso a quello del BLOCCAGGIO MANUALE facendo attenzione a rimettere il perno di bloccaggio nel supporto sul telaio.

Rimozione (e posa) dell'accessorio

Procedere in senso inverso a quello della PRESA DELL'ACCESSORIO facendo attenzione a posare il medesimo in posizione sicura su suolo compatto e piano. Se l'accessorio è dotato di sistema idraulico, innestare gli attacchi rapidi o viceversa disinnestarli in caso di smontaggio accessorio previa decompressione del circuito.



Mantenete puliti gli innesti rapidi e proteggete gli orifizi non utilizzati con gli appositi tappi.

US

ASSEMBLING THE ATTACHMENT WITH MANUAL BLOCK

Fitting the attachment

- Check to make sure the attachment is in a position which makes it easier to fit the quick-release coupling. If it is not oriented properly, take the necessary precautions to shift it to the conditions of maximum safety.
- Check to make sure the locking pin is inserted in the support provided on the chassis.
- Position the forklift truck with the boom lowered completely in front and parallel to the attachment and tilt the quick-release coupling forwards (Fig. A).
- Bring the quick-release coupling under the connecting hose of the attachment, raise the boom slightly and tilt the coupling backwards to position the attachment (Fig. B).
- Disengage the attachment from the ground to facilitate blocking.
- Confirm the identification of the attachment shown on the display (1, Fig. D).

Manual blocking

Take the locking pin on the support and insert it in the hole provided in the quick-release coupling to block the attachment (Fig. C). Remember to fit the split pin.

Manual release

Repeat the MANUAL BLOCKING procedure in reverse order taking care to refit the locking pin in the support on the chassis.

Removing (and placing) the attachment

Repeat the FITTING THE ATTACHMENT procedure in reverse order, taking care to place it in a safe position on compact, level ground. If the attachment is provided with a hydraulic system, fit the quick-release couplings or disconnect these for dismantling the attachment after decompression of the circuit.



Keep the quick-release couplings clean and protect the unused holes by means of plugs.

NL

MONTAGE VAN HET WERKTUIG MET HANDMATIGE BLOKKERING

Werktuig aankoppelen

- Controleer of het werktuig in een positie staat voor een makkelijke aankoppeling van de snelkoppeling. Als het niet goed staat, tref dan alle nodige voorzorgsmaatregelen om het veilig te verplaatsen.
- Controleer of de blokkeerpen in zijn steun op het chassis gestoken is.
- Zet de heftruck met de arm naar beneden gehaald tegenover en parallel ten opzichte van het werktuig plaatsen en zet de snelkoppeling voren (Fig. A).
- Breng de snelkoppeling onder de koppeling van het werktuig, til de arm iets op en hel de snelkoppeling zelf achterover om het werktuig te plaatsen (Fig. B).
- Haal het werktuig van de grond af om de vergrendeling te vergemakkelijken.
- Bevestig de herkenning van het werktuig* op het display (1, Fig. D).

Handmatige vergrendeling

Neem de blokkeerpen op de steun en steek hem in het gat van de snelkoppeling om het werktuig te blokkeren (Fig.C). Vergeet niet de splitpen aan te brengen.

Handmatige ontgrendeling

De handelingen van de HANDMATIGE VERGRENDELING in omgekeerde volgorde uitvoeren en er hierbij op letten de blokkeerpen weer in de steun op het chassis te plaatsen.

Verwijderen (en neerzetten) van het werktuig

De handelingen van WERKTUIG AANKOPPELEN in omgekeerde volgorde uitvoeren en er hierbij op letten het werktuig in een veilige positie op een compact en vlak stuk grond neer te zetten. Als het werktuig voorzien is van hydraulisch systeem, de snelkoppelingen aan- of loskoppelen na de druk van het circuit gehaald te hebben.



Houd de snelkoppelingen schoon en bescherm de niet gebruikte openingen met de speciale doppen.

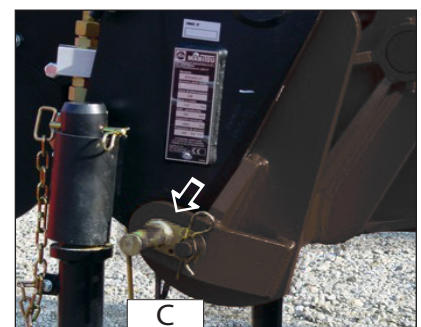
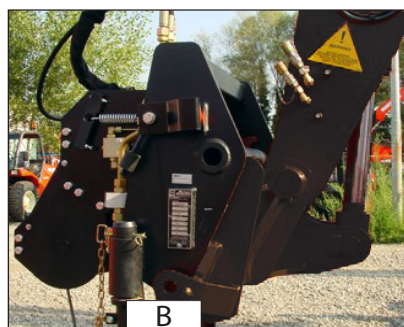
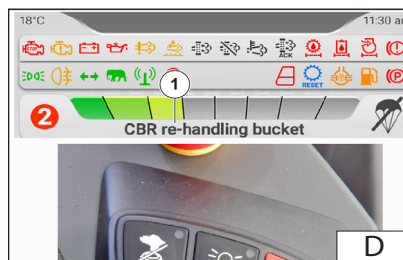

IT

MONTAGGIO DELL'ACCESSORIO CON BLOCCO IDRAULICO (opzionale).

Presa dell'accessorio

- Verificare che l'accessorio sia in una posizione che faciliti l'aggancio dell'attacco rapido. Nel caso in cui fosse male orientato, prendete le precauzioni necessarie per spostarlo in condizioni di massima sicurezza.
- Verificare che le aste del martinetto di bloccaggio siano rientrate.
- Posizionare il carrello elevatore con il braccio abbassato ben di fronte e parallelo all'accessorio e inclinare l'attacco rapido in avanti (Fig.A).
- Portare l'attacco rapido sotto il tubo d'aggancio dell'accessorio, alzare leggermente il braccio e inclinare l'attacco stesso all'indietro per posizionare l'accessorio (Fig.B).
- Disimpegnare l'accessorio dal suolo per agevolare il bloccaggio.
- Azionare il comando optional per bloccare l'accessorio.
- Confermare il riconoscimento dell'accessorio a display (1, Fig. D).

Bloccaggio e sbloccaggio idraulico (opzionale) (Fig. E).

Il bloccaggio e lo sbloccaggio di un eventuale accessorio avviene tramite l'utilizzo del comando optional (comando che può essere azionato da un apposito pulsante o dal manipolatore stesso a seconda del tipo di carrello elevatore che si possiede) tramite i perni che debbano fuoriuscire dai fori dell'attacco rapido (Fig. C).

Rimozione (e posa) dell'accessorio

Procedere in senso inverso a quello della PRESA DELL'ACCESSORIO facendo attenzione a posare il medesimo in posizione sicura su suolo compatto e piano.

US

ASSEMBLING THE ATTACHMENT WITH HYDRAULIC BLOCK (OPTIONAL).

Fitting the attachment

- Check to make sure the attachment is in a position which makes it easier to fit the quick-release coupling. If it is not oriented properly, take the necessary precautions to shift it to the conditions of maximum safety.
- Check to make sure the locking cylinder rods are retracted.
- Position the forklift truck with the boom lowered completely in front and parallel to the attachment and tilt the quick-release coupling forwards (Fig. A).
- Bring the quick-release coupling under the connecting hose of the attachment, raise the boom slightly and tilt the coupling backwards to position the attachment (Fig. B).
- Disengage the attachment from the ground to facilitate blocking.
- Activate the optional command to block the attachment.
- Confirm the identification of the attachment shown on the display (1, Fig. D).

Hydraulic block and release (optional) (Fig. E).

Blocking and release of an attachment, if present, is done by means of the optional command (which may be activated by means of a pushbutton provided for the purpose or by the manipulator itself, depending on the type of forklift truck in your possession) by means of the pins which must project out through the holes in the quick-release coupling (Fig. C).

Removing (and placing) the attachment

Repeat the FITTING THE ATTACHMENT procedure in reverse order, taking care to place the attachment in a safe position on compact, level ground.

NL

MONTAGE VAN HET WERKTUIG MET HYDRAULISCHE BLOKKERING (optioneel).

Werktuig aankoppelen

- Controleer of het werktuig in een positie staat voor een makkelijke aankoppeling van de snelkoppeling. Als het niet goed staat, tref dan alle nodige voorzorgsmaatregelen om het veilig te verplaatsen.
- Controleer of de stangen van de aankoppelcilinder ingeschoven zijn.
- Zet de heftruck met de arm naar beneden gehaald tegenover en parallel ten opzichte van het werktuig plaatsen en zet de snelkoppeling voren (Fig. A).
- Breng de snelkoppeling onder de koppelstang van het werktuig, til de arm iets op en hel de snelkoppeling zelf achterover om het werktuig te plaatsen (Fig. B).
- Haal het werktuig van de grond af om de vergrendeling te vergemakkelijken.
- Gebruik de optionele bediening om het werktuig te blokkeren.
- Bevestig de herkenning van het werktuig* op het display (1, Fig. D).

Hydraulisch vergrendelen en ontgrendelen (optioneel) (Fig. E).

Een eventueel werktuig wordt vast- en losgemaakt met behulp van de optionele bediening (aansturing die met een speciale knop of de stuurknuppel zelf bediend kan worden naar gelang het type heftruck in uw bezit) door middel van de pennen die door de gaten van de snelkoppeling naar buiten moeten komen (Fig. C).

Verwijderen (en neerzetten) van het werktuig

De handelingen van WERKTUIG AANKOPPELEN in omgekeerde volgorde uitvoeren en er hierbij op letten het werktuig in een veilige positie op een compact en vlak stuk grond neer te zetten.

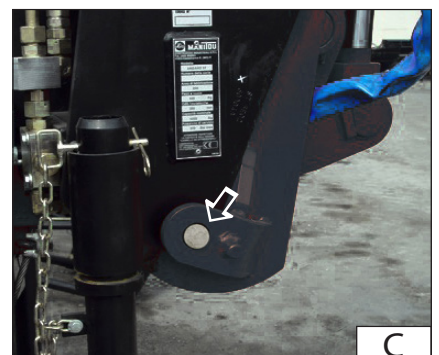
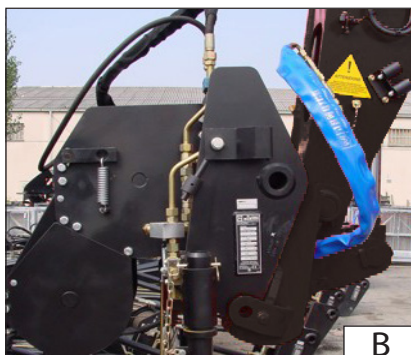
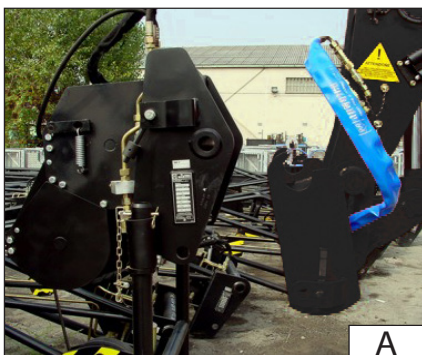
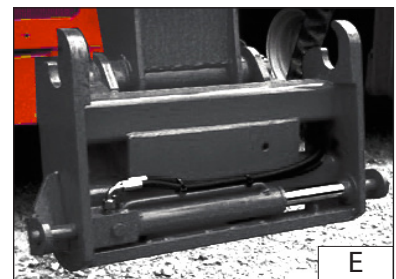
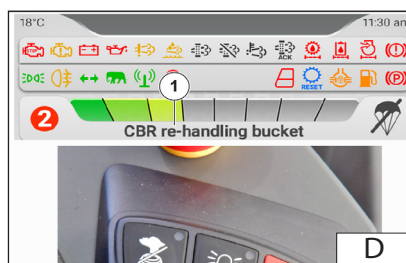



IT

INATTIVITA' PROLUNGATA DELLA MACCHINA

Se la macchina deve rimanere per lungo tempo inoperosa è necessario adottare alcune precauzioni importanti per il mantenimento della stessa.

- Scegliere un luogo con superficie il più possibile orizzontale e compatta, possibilmente protetta dagli agenti atmosferici e dall'accesso di persone non autorizzate, sulla quale parcheggiare la vostra macchina.
- Portare la leva dell'invertitore di marcia in posizione neutra.
- Azionare il freno di stazionamento.
- Abbassare gli stabilizzatori per alleggerire il carico gravante sui pneumatici.
- Arrestare il motore termico e togliere la chiave di avviamento dal cruscotto.
- Chiudere sempre a chiave le porte della cabina e tutti gli sportelli.
- Procedere alla pulizia generale della macchina.
- Sostituire completamente tutti i lubrificanti e lubrificare la macchina.
- Sostituire le parti danneggiate o eccessivamente usurate con ricambi originali e ritoccare la verniciatura, ove necessari, per prevenire formazioni di ruggine.
- Ingrassare tutti gli organi provvisti di ingrassatori.
- Spruzzare o cospargere un leggero velo di grasso protettivo neutro sulle aste dei cilindri idraulici e su tutte le parti sverniciate della macchina.
- Riempire completamente il serbatoio carburante per evitare formazioni di ruggine.
- Lubrificare le guarnizioni esterne della carrozzeria con appositi lubrificanti, per evitare il degrado.
- Scollegare i morsetti della batteria, pulirli e coprirli con un velo di grasso neutro.
- Togliere la batteria e conservarla in un luogo temperato ed asciutto.

US

LONG SHUTDOWNS OF THE VEHICLE

If the vehicle is to remain unused for long periods, important precautions must be taken to ensure it remains in good condition.

- Choose a place with the most compact, level floor available, protected against the weather and access by unauthorised persons if possible, to park your truck.
- Place the reverse gear lever in the neutral position.
- Apply the parking brake.
- Lower the stabilisers to lighten the load on the tyres.
- Stop the I.C. engine and remove the ignition key from the dashboard.
- Always lock all cab doors and all machine access hatches.
- Carry out general cleaning of the vehicle.
- Change all the lubricants completely and lubricate the vehicle.
- Replace damaged or excessively worn parts with original spare parts and touch up the paintwork, where necessary, to prevent rusting.
- Grease all components fitted with grease nipples.
- Spray or spread a thin film of neutral protective grease on the rods of the hydraulic cylinders and on all parts of the machine which are not painted.
- Fill the fuel tank to capacity to prevent rusting.
- Lubricate the outer gaskets of the body using special lubricants, to prevent deterioration.
- Disconnect the battery terminals, clean them and coat them with neutral grease.
- Remove the battery and store it in a cool, dry place.

NL

ALS DE MACHINE EEN LANGE PERIODE NIET GEBRUIKT WORDT

Als de machine een lange tijd niet gebruikt wordt moeten er enkele voorzorgsmaatregelen getroffen worden.

- Kies voor het parkeren van uw heftruck een plaats met een zo vlak en compact mogelijk oppervlak, mogelijkerwijs beschermd tegen de weersomstandigheden en de toegang van onbevoegde personen.
- Zet de hendel van de omkeerinrichting in zijn vrij.
- Trek de handrem aan.
- Zet de stabilisatoren naar beneden om de belasting op de banden te verlichten.
- Zet de verbrandingsmotor af en haal de contactsleutel van het dashboard.
- Draai altijd het cabineportier en de andere deuren op slot.
- Maak de hele heftruck schoon.
- Vervang alle smeermiddelen volledig en smeer de machine.
- Vervang de beschadigde of te erg versleten onderdelen door originele reserveonderdelen en tip de lak aan waar nodig om roestvorming te voorkomen.
- Vet alle onderdelen in die voorzien zijn van smeernippels.
- Spuit of smeer een dun laagje neutraal beschermvet op de stangen van de hydraulische cilinders en op alle ongeverfde delen van de heftruck.
- Vul de brandstoftank volledig om roestvorming te voorkomen.
- Smeer de externe afdichtingen van de carrosserie met speciale smeermiddelen om verslechtering te voorkomen.
- Schakel de accuklemmen los, maak ze schoon en bedek ze met een laagje neutraal vet.
- Verwijder de accu en berg hem op een gematigde en droge plaats op.



IT

**RIMESSA IN SERVIZIO DELLA
MACCHINA**

Prima di riprendere il lavoro dopo una lunga inattività è necessario:

- Rimontare la batteria, dopo averla ricaricata.
- Controllare la pressione dei pneumatici.
- Pulire la macchina dal grasso di protezione.
- Controllare tutti i livelli dei lubrificanti ed eventualmente rabboccare.
- Sostituire il filtro dell'aria di combustione.
- Ingrassare tutti gli organi provvisti di ingrassatori.
- Avviare il motore della macchina e farlo funzionare a vuoto per una decina di minuti.
- Far funzionare la macchina a vuoto e verificare tutti i movimenti.

US

**PUTTING THE VEHICLE BACK
INTO OPERATION**

Before resuming work after a long shutdown:

- Refit the battery, after recharging it.
- Check the tyre pressure.
- Clean the machine to remove the protective grease.
- Check all the lubricant levels and top up, if necessary.
- Change the combustion air filter.
- Grease all components fitted with grease nipples.
- Start up the engine and run it idle for about ten minutes.
- Operate the machine without load and check all movements.

NL

**DE HEFTRUCK WEER IN BEDRIJF
STELLEN**

Voor het werk te hervatten na een lange periode dat de heftruck niet gebruikt is:

- Monteer de accu weer na hem opgeladen te hebben.
- Controleer de bandenspanning.
- Verwijder het beschermvet van de heftruck.
- Kijk alle smeermiddeelniveaus na en vul ze eventueel bij.
- Vervang het verbrandingsluchtfILTER.
- Vet alle onderdelen in die voorzien zijn van smeernippels.
- Start de motor van de heftruck en laat hem onbelast gedurende ongeveer tien minuten draaien.
- Laat de machine onbelast werken en controleer alle bewegingen.





**2 - *DIMENSIONI -
USO e MANUTENZIONE***
***DIMENSIONS -
USE and MAINTENANCE***
***AFMETINGEN -
GEBRUIK en ONDERHOUD***



IT

FUNZIONI COMANDI IN CABINA

1. Inclinazione in avanti dell'accessorio gru
2. Inclinazione all'indietro dell'accessorio gru
3. Discesa del braccio telescopico con accessorio gru.
4. Salita del braccio telescopico con accessorio gru.
5. Rientro sfili del braccio telescopico con accessorio gru.
6. Uscita sfili del braccio telescopico con accessorio gru.
7. Salita fune dell'accessorio gru.
8. Discesa fune dell'accessorio gru
9. Rotazione in senso antiorario della torretta.
10. Rotazione in senso orario della torretta.

US

FONCTION DES COMMANDES DANS LA CABINE

1. Crane attachment tilted forwards
2. Crane attachment tilted backwards
3. Telescopic boom descent with crane attachment
4. Telescopic boom ascent with crane attachment
5. Telescopic boom extensions retracted with crane attachment
6. Telescopic boom extensions out with crane attachment
7. Crane attachment rope ascent.
8. Crane attachment rope descent.
9. Anticlockwise rotation of the turret.
10. Clockwise rotation of the turret.

NL

FUNCTIES VAN DE BEDIENINGEN IN DE CABINE

1. Kraanwerktuig voorover hellen
2. Kraanwerktuig achterover hellen
3. Telescopische arm met kraanwerktuig omlaag.
4. Telescopische arm met kraanwerktuig omhoog.
5. Telescopische arm met kraanwerktuig intrekken.
6. Telescopische arm met kraanwerktuig uitschuiven.
7. Kabel van het kraanwerktuig omhoog.
8. Kabel van het kraanwerktuig omlaag.
9. Draaiing van de zwenkkop tegen de richting van de klok in.
10. Draaiing van de zwenkkop in de richting van de klok.

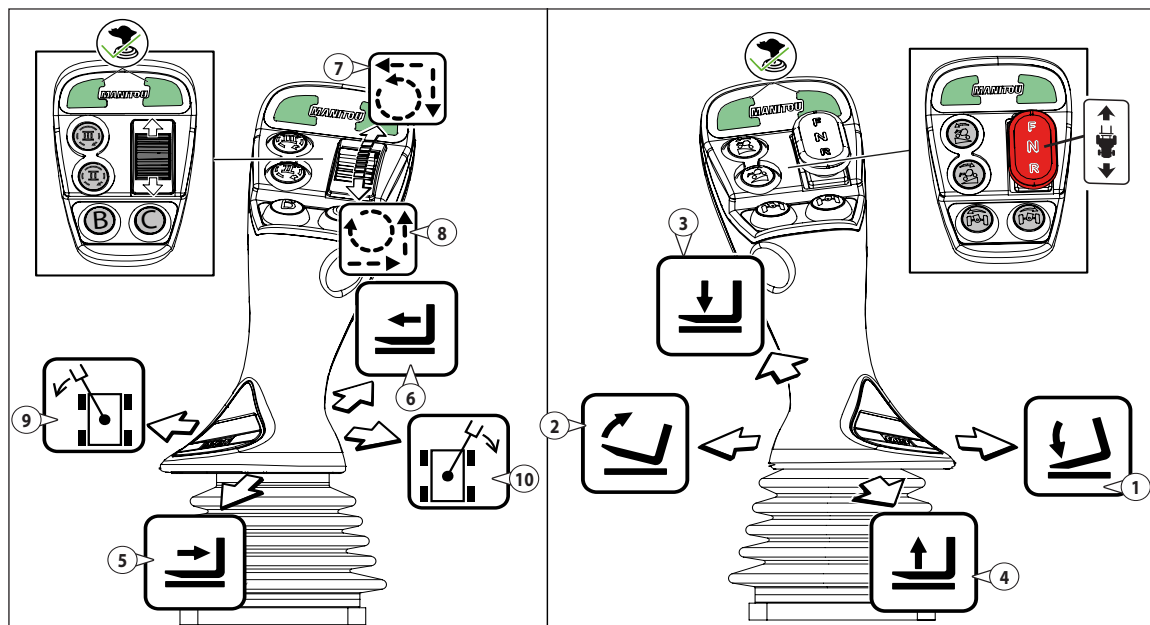

IT

FUNZIONI RADIOCOMANDO

1. Pulsante per confermare il riconoscimento dell'accessorio a display.
2. Consenso avviamento motore e clacson. Azionare il clacson quando il Radiocomando è avviato.
3. M-KEY: La M-Key permette di alimentare l'Unità trasmittente. Spingere fino in fondo la M-Key all'interno della relativa sede di alloggiamento.
4. Pulsante elettropompa di emergenza per il salvataggio della piattaforma:
 - Per arretrare il braccio telescopico: mantenere premuto il pulsante per azionare la pompa di salvataggio.
 - Eseguire solamente le manovre strettamente necessarie per ritornare a terra.
5. Pulsante avviamento motore:
 - Prima dell'accensione, occorre disinserire il pulsante rosso di ARRESTO D'EMERGENZA.
 - Premere il pulsante (2) poi premere sul pulsante (5) per accendere il motore.
6. Connettore filocomando. Consenso manovre dalla piattaforma.
7. Scorrimento pagine del display.
8. Illuminazione del display.
9. Non utilizzato.
10. Pulsante accensione luci braccio telescopico.
11. Pagina visualizzazione e scorrimento accessori.
12. Display a colori da 2,8" che visualizza le informazioni di lavoro e stabilità della macchina, avvisi del motore, accessorio in uso.
13. Joystick destro:
 - Sollevamento/discesa braccio.
 - Inclinazione in avanti/indietro del carico (TILT selezionato).
 - Comando accessorio AUX (AUX selezionato).

US

RADIO CONTROL

1. Button to confirm the recognition of the accessory on the display.
2. Engine and horn start consent. Sound the horn when the radio control is started.
3. M-KEY: The M-Key allows you to power the transmitting unit. Push the M-Key all the way into its housing seat.
4. Emergency electric pump button for platform rescue:
 - To retract the telescopic arm: keep the button pressed to activate the rescue pump.
 - Carry out only the maneuvers strictly necessary to return to the ground.
5. Engine start button:
 - Before switching on, the red EMERGENCY STOP button must be disconnected.
 - Press button (2) then press button (5) to start the engine.
6. Wired control connector. Consent to maneuvers from the platform.
7. Scroll display pages.
8. Display illumination.
9. Not used.
10. Telescopic arm lights switch.
11. Accessory display and scrolling page.
12. 2.8 "color display that displays machine working and stability information, engine warnings, accessory in use.
13. Right joystick:
 - Arm lifting / lowering.
 - Forward / backward inclination of the load (TILT selected).
 - AUX accessory control (AUX selected).

NL

FUNCTIES AFSTANDSBEDIENING

1. Knop voor bevestiging van de herkenning van het hulpstuk op het display.
2. Toestemming voor het starten van de motor en de claxon. De claxon inschakelen als de radiobesturing wordt gestart.
3. M-KEY: Met de M-Key kan de zender van stroom worden voorzien. Duw de M-Key helemaal in zijn behuizing.
4. Knop voor de elektrische noodpomp voor redding van het platform:
 - De telescooparm inschuiven: houd de toets ingedrukt om de reddingspomp te activeren.
 - Voer alleen manoeuvres uit die strikt noodzakelijk zijn om naar de grond terug te keren.
5. Starttoets motor:
 - Vóór het inschakelen moet de rode NOODSTOP-toets worden uitgezet.
 - Druk op de toets (2) en daarna op de toets (5) om de motor te starten.
6. Bedrade besturingsconnector. Manoeuvres toegestaan vanaf het platform.
7. Bladeren door pagina's op het display.
8. Verlichting display.
9. Niet in gebruik.
10. Lichtschakelaar telescooparm.
11. Display hulpstuk en door pagina's bladeren.
12. Kleurendisplay van 2,8" dat werk- en stabiliteitsinformatie over de machine, motorwaarschuwingen en het gebruikte hulpstuk weergeeft.
13. Joystick rechts:
 - Arm omhoog / Omlaag.
 - Voorwaarts / achterwaarts kantelen van de lading (gekozen KANTELING).
 - AUX-bediening hulpstuk (geselecteerde AUX).

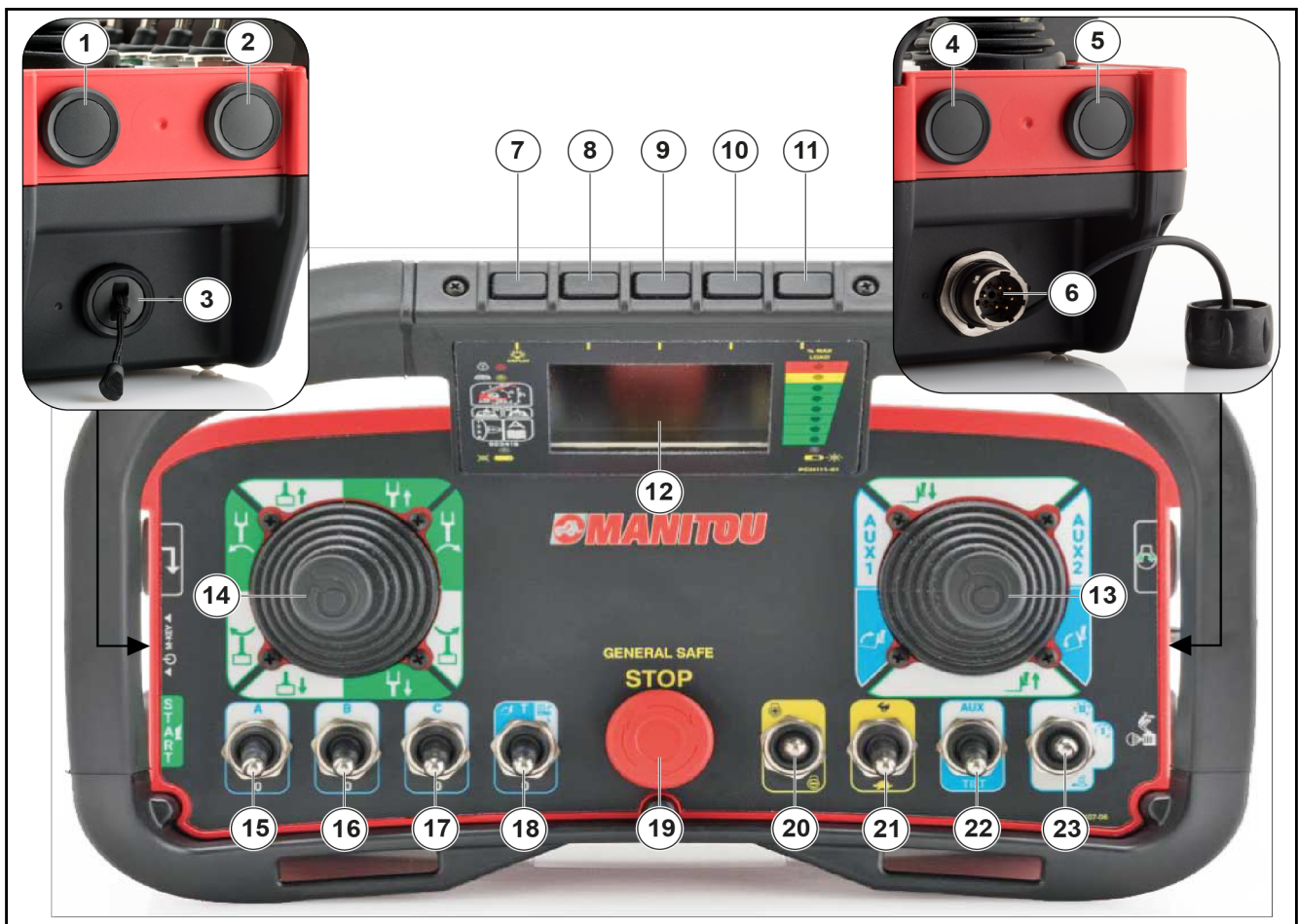



IT

14. Joystick sinistro:
 - Estensione/retrazione braccio telescopico.
 - Rotazione torretta.
15. Selettore movimenti accessorio.
16. Selettore movimenti accessorio - 12V in testa braccio.
17. Selettore movimenti accessorio.
18. Consenso inclinazione carico o livellamento piattaforma.



Il brandeggio del cesto o l'inclinazione della piattaforma sono consentiti solo sotto i 3 m di altezza.

19. Pulsante rosso "ARRESTO DI EMERGENZA". Se premuto, permette di arrestare il motore termico.
In caso di pericolo, permette all'utilizzatore di arrestare i movimenti idraulici.
Per ripristinare i movimenti idraulici ruotare il pulsante rosso in senso orario.
20. Interruttore gestione giri motore (RPM).
21. Selettore velocità dei movimenti idraulici.
22. Selettore movimento AUX (accessorio) o TILT (inclinazione carico/cesto).
23. Movimenti multipli dell'accessorio: "I/II" e "Bloccaggio idraulico dell'accessorio".

Joystick, selettori, pulsanti funzioni macchina

13-14 - Manipolatore.
Azionare il manipolatore per effettuare i movimenti desiderati seguendo le frecce colorate.
I movimenti dei cestelli si devono considerare invertiti durante il lavoro in posizione negativa "↓" (Cestello 3D, Aerial Jib 2).

15-16-17 - Commutatore movimenti.
Ad ogni posizione (A-B-C-D) corrisponde una coppia di comandi eseguibile simultaneamente.

I movimenti e le combinazioni possibili sono visualizzato sullo schermo

US

14. Left joystick:
 - Extension / retraction of the telescopic arm.
 - Turret rotation.
15. Accessory movement selector.
16. Accessory movement selector - 12V in the arm head.
17. Accessory movement selector.
18. Load tilting or platform leveling consent.



The slewing or inclination of the platform are allowed only below 3m height.

19. Red button "EMERGENCY STOP".
If pressed, it allows to stop the heat engine. In case of danger, it allows the user to stop hydraulic movements.
To restore the hydraulic movements, turn the red button clockwise.
20. Engine speed management switch (RPM).
21. Speed selector for hydraulic movements.
22. AUX (accessory) or TILT (load / basket tilt) movement selector.
23. Multiple movements of the accessory: "I / II" and "Hydraulic locking of the accessory".

Joystick, selectors, machine functions buttons macchina

13-14 - Joystick.
Operate the manipulator to make the required movements by following the coloured arrows.
The platform movements must be considered as inverted when working in the negative position "↓" (System 3D, Aerial Jib 2).

15-16-17 - Movements switch.
Each position (A-B-C-D) has a corresponding pair of commands that can be executed simultaneously.

The movements and possible combinations are displayed on the screen.

NL

14. Joystick links:
 - Telescooparm inschuiven / uitschuiven.
 - Draaien van het draaimechanisme.
15. Keuzeschakelaar voor beweging hulpstuk.
16. Keuzeschakelaar voor beweging hulpstuk - 12 V in de kop van de arm.
17. Keuzeschakelaar voor beweging hulpstuk.
18. Lading kantelen of toestemming platform nivelleren.



De kantelbewegingen van de kooi of het platform zijn alleen toegestaan onder 3 meter hoogte.

19. Rode toets 'NOODSTOP'.
Wanneer deze toets wordt ingedrukt, kunt u hiermee de warmtemotor stoppen.
Bij gevaar kan de gebruiker hiermee de hydraulische bewegingen stoppen.
Draai de rode toets rechtsom om de hydraulische bewegingen weer te hervatten.
20. Schakelaar voor beheer motortoerental (tr/min).
21. Keuzeschakelaar voor snelheid van hydraulische bewegingen.
22. Keuzeschakelaar voor beweging van AUX (hulpstuk) of TILT (lading/mand kantelen).
23. Meerdere bewegingen van het hulpstuk: 'I / II' en 'Blokking hydraulisch hulpstuk'.

Joysticks, keuzeschakelaars, knoppen voor machinefuncties

13-14 - Stuurknuppel.
Gebruik de stuurknuppel om de gewenste bewegingen te maken volgens de gekleurde pijlen. De bewegingen van de werkkooien moeten omgekeerd beschouwd worden als er in negatieve positie "↓" gewerkt wordt (werkkooi 3D, Aerial Jib 2).

15-16-17 - Bewegingsschakelaar
Bij elke positie (A-B-C-D) hoort een paar gelijktijdig uitvoerbare bedieningen.

De bewegingen en mogelijke combinaties worden weergegeven op het scherm.

IT

US

NL

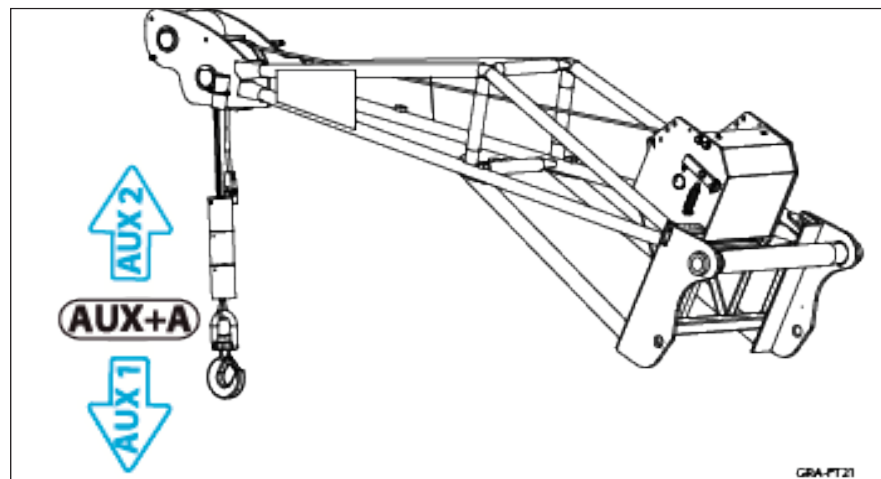
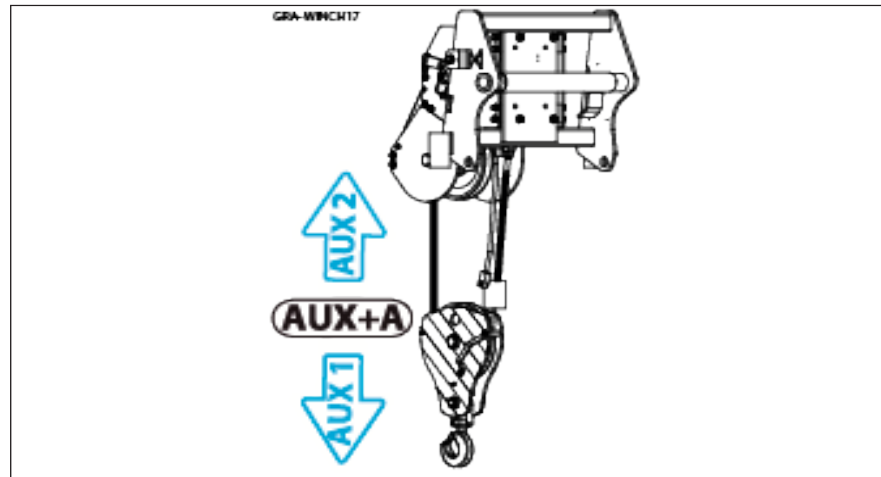



IT

CARATTERISTICHE BRACCETTI E ARGANI

GAMMA BRACCETTI E ARGANI

(Secondo modello di macchina)

ARGANO IDRAULICO

- ARGANO 3T
- ARGANO 3T TD
- ARGANO 4T
- ARGANO 5T

ARGANO IDRAULICO SU BRACCIO

- ARGANO 5,5T

BRACCETTO TRALICCIATO

- P 600
- P 1000
- P 1200
- P 1500
- P 2000

BRACCETTO A 2 GANCI FISSI

- P 4000
- P 6000

BRACCETTO TRALICCIATO CON ARGANO

- PT 600
- PT 1000
- PT 1200
- PT 1500
- PT 2000

BRACCETTO TRALICCIATO ESTENSIBILE CON ARGANO

- PT 800

BRACCETTO CON GANCIO FISSO

- PC 30
- PC 40
- PC 50
- PC 60

MANIPOLATORE BIG-BAG

- HBB 1500-2400

US

CHARACTERISTICS OF JIB & CRANE AND WINCHES

RANGE JIB & CRANE AND WINCHES

(Depending on the machine model)

HYDRAULIC WINCH

- WINCH 3T
- WINCH 3T TD
- WINCH 4T
- WINCH 5T

HYDRAULIC WINCH ON THE BOOM

- WINCH 5,5T

EXTENSION JIB

- P 600
- P 1000
- P 1200
- P 1500
- P 2000

CRANE

- P 4000
- P 6000

EXTENSION JIB WITH WINCH

- PT 600
- PT 1000
- PT 1200
- PT 1500
- PT 2000

EXPANDABLE JIB WITH WINCH

- PT 800

FRAME MOUNTED HOOK

- PC 30
- PC 40
- PC 50
- PC 60

BIG-BAG HANDLER

- HBB 1500-2400

NL

KENMERKEN ARMEN EN LIEREN

ASSORTIMENT ARMEN EN LIEREN

(Naar gelang model machine)

HYDRAULISCHE LIER

- WINCH 3T
- WINCH 3T TD
- WINCH 4T
- WINCH 5T

HYDRAULISCHE LIER OP ARM

- WINCH 5,5T

VERLENGDE ARM

- P 600
- P 1000
- P 1200
- P 1500
- P 2000

ARM MET 2 VASTE HAKEN

- P 4000
- P 6000

VERLENGDE ARM MET LIER

- PT 600
- PT 1000
- PT 1200
- PT 1500
- PT 2000

VERLENGDE ARM UITBREIDBAAR MET LIER

- PT 800

ARM MET VASTE HAAK

- PC 30
- PC 40
- PC 50
- PC 60

MANIPULATOR VOOR "BIG BAGS"

- HBB 1500-2400



WINCH 3T

IT

ARGANO 3 T

Descrizione:

Argano idraulico 3t

Caratteristiche:

- Tiro al 3° strato di 3000Kg.
- Velocità massima al 3° strato 23mt/min
- Il tiro è in due taglie.
- La fune è di 49mt, diametro 10mm disposta su tre strati.
- Motore orbitale Sauer-Danfoss OMSU
- Riduttore epicicloidale con freno negativo a dischi in bagno d'olio.
- Il tamburo è filettato e dotato di un rullo pressa fune in modo da assicurare sempre un corretto avvolgimento della fune.
- Presenza di un guida fune che migliora ulteriormente l'avvolgimento della fune sul tamburo.
- Classificazione ISO 4301/1: T4,L2,M4.

Sicurezze:

- Fine corsa discesa idraulico positivo.
- Fine corsa salita idraulico positivo.

US

WINCH 3 T

Description:

3t Hydraulic winch

Features:

- Pull at 3rd layer 3000kg.
- Maximum speed at 3rd layer 23 m/min
- The pull is in two sheaves.
- The rope is 49 m long, 10mm diameter arranged in three layers.
- Sauer-Danfoss OMSU orbital motor
- Planetary drive with negative oil bath disk brake
- The drum is threaded and provided with a rope press roller in order to always ensure correct winding of the rope.
- Presence of a rope guide which further improves the winding of the rope on the drum.
- ISO 4301/1 Classification: T4, L2, M4.

Safety devices:

- Positive hydraulic descent limit switch.
- Positive hydraulic ascent limit switch.

NL

WINCH 3 T

Beschrijving:

Hydraulische lier 3t

Kenmerken:

- Trekkracht 3de laag 3000 kg.
- Maximumsnelheid 3de laag 23 m/min.
- Kabel dubbel gebruikt.
- De kabel is 49 m, diameter 10 mm in drie lagen.
- Sauer-Danfoss OMSU orbitmotor
- Planetaire reductor met negatieve schijvenrem in oliebad.
- De trommel is gegleufd en voorzien van een kabelandrukrol voor een altijd correcte opwikkeling van de kabel.
- Aanwezigheid van een kabelgeleider voor een nog betere opwikkeling van de kabel op de trommel.
- Classificatie ISO 4301/1: T4,L2,M4.

Beschermingen:

- Positieve hydraulische eindaanslag daling.
- Positieve hydraulische eindaanslag stijging.





[kg] (lb)	[t] (t)	[mm] (in) x [m] (ft)	[m/min] (ft/min)	[bar] (psi)	[mm] (in)													[kg] (lb)
				P max														
3000 (6614)	5 (5)	∅ 10 (0,4) x 49 (160)	23 (75)	210 (3045)	A	B	C	D	E	F	G	H	I	L	M	N	395 (870)	
					1810 (71)	900 (35)	506 (20)	730 (29)	353 (14)	270 (11)	750 (29)	750 (29)	780 (31)	873 (35)	680 (27)	200 (8)		

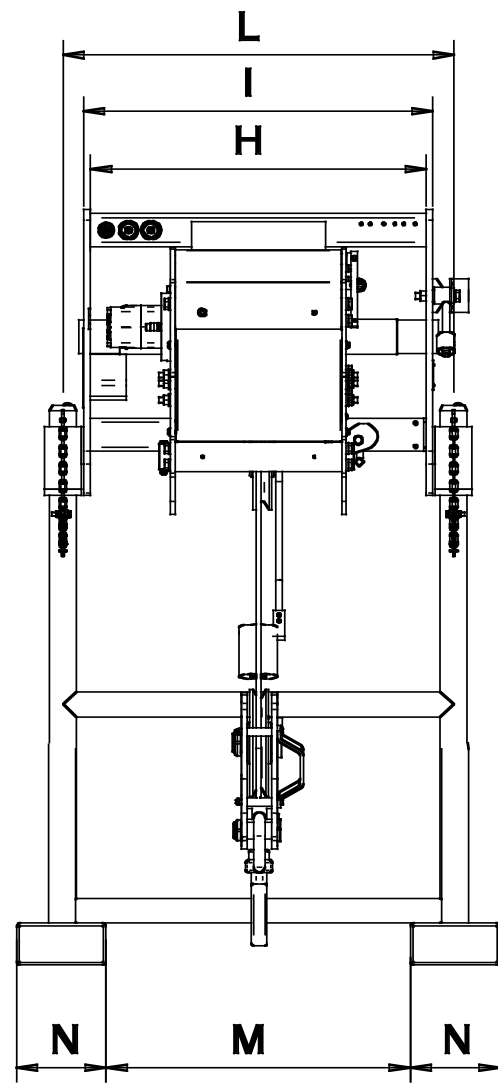
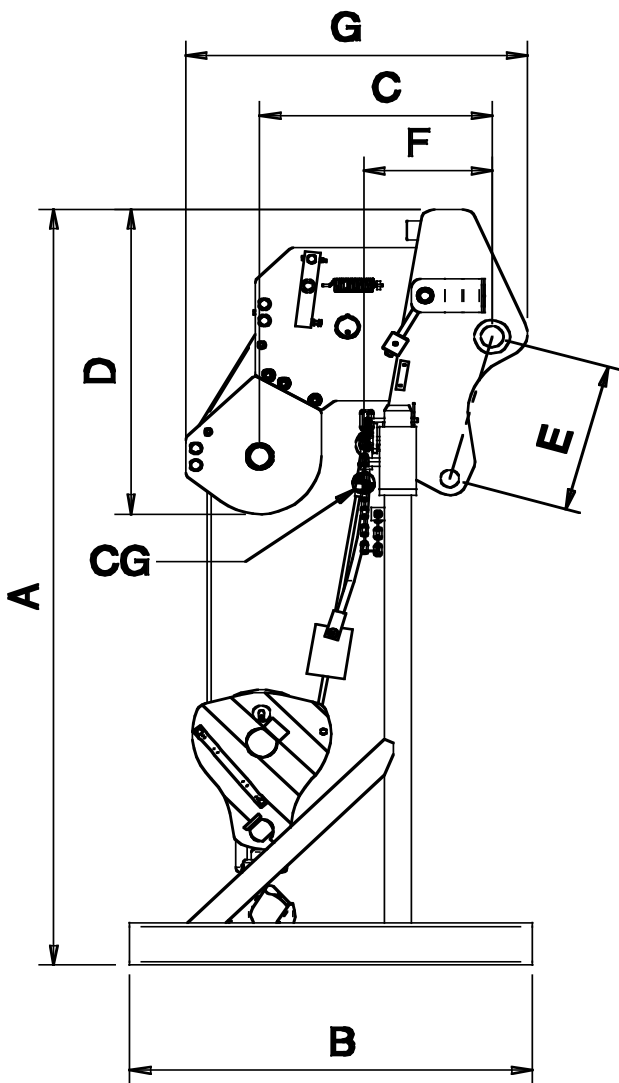

IT

MESSA IN SERVIZIO E UTILIZZO

Per la vostra sicurezza, prima di iniziare un ciclo di lavoro, attenersi alle Istruzioni obbligatorie di verifica e controllo:

- verificare l'integrità della struttura esterna dell'argano.
- verificare il corretto collegamento idraulico degli innesti rapidi 1, 2, Drenaggio e lo stato dei tubi flessibili (Fig.1);
- controllare il corretto funzionamento del fine corsa discesa fune H (Fig.2);
- controllare il corretto funzionamento del fine corsa salita fune L (Fig.2);
- controllare lo stato della fune e il corretto avvolgimento sul tamburo A (Fig.3);
- controllare il corretto movimento laterale e di rotazione della puleggia di guida fune B (Fig.3);
- controllare lo stato dei capocorda C (Fig.4) e E (Fig.5);

US

STARTING UP AND USE

For your safety, before starting a work cycle, follow the Compulsory instructions for inspection and control:

- check to make sure the external structure of the winch is intact.
- Check to ensure the correct hydraulic connection of quick-release couplings 1, 2, drainage and the condition of the hose pipes (Fig.1);
- check to ensure correct working of the rope descent limit switch H (Fig.2);
- check to ensure correct working of the rope ascent limit switch L (Fig.2);
- check the condition of the rope and that it is wound correctly on the drum A (Fig.3);
- check the correct lateral movement and rotation of the rope guide pulley B (Fig.3);
- check the condition of cable terminals C (Fig.4) and E (Fig.5);

NL

INBEDRIJFSTELLING EN GEBRUIK

Houd u, voor uw eigen veiligheid, voor met een werkcyclus aan te vangen, aan de verplichte controle-instructies:

- controleer of de buitenste structuur van de lier intact is.
- controleer of de hydraulische verbinding van de snelkoppelingen 1, 2, Afvoer en de staat van de slangen in orde zijn (Fig.1);
- controleer de werking van de eindslag kabel omlaag H (Fig.2);
- controleer de werking van de eindslag kabel omhoog L (Fig.2);
- controleer de staat van de kabel en de opwikkeling op de trommel A (Fig.3);
- controleer de zijdelingse beweging en draaibeweging van het kabelgeleidewiel B (Fig.3);
- controleer de staat van het kabeluiteinde C (Fig.4) en E (Fig.5);

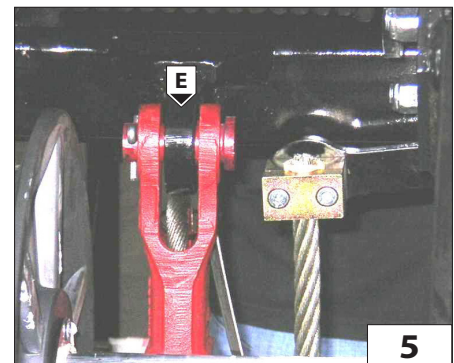
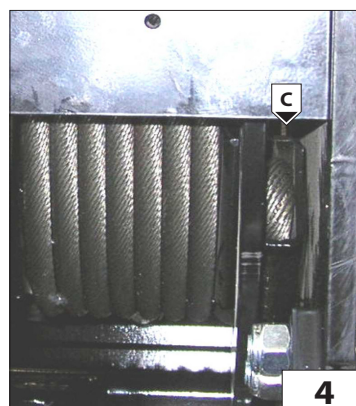
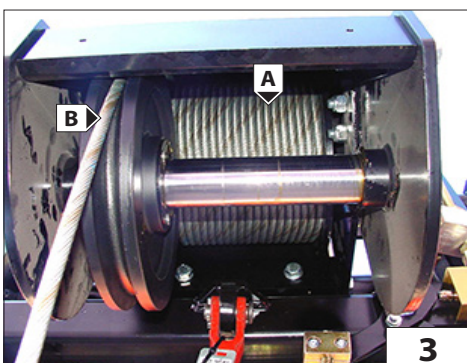
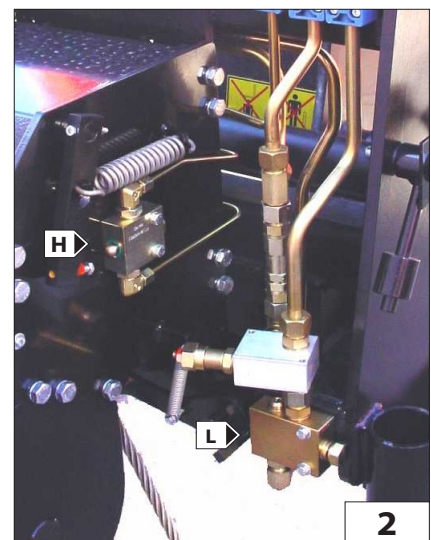
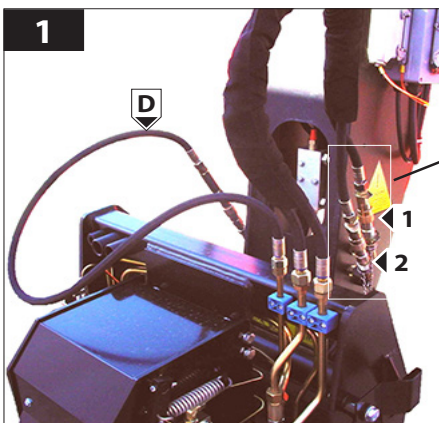

IT

- verificare l'integrità del bozzello e la
- rotazione della sua puleggia F (Fig.6);
- verificare lo stato del gancio: che non sia deformato, che ruoti liberamente e che la linguetta di sicurezza sia efficiente G (Fig.6);
- controllare l'aggancio dell'argano alla macchina operatrice J (Fig.7).

Per l'utilizzo, dalla posizione di parcheggio, sganciare l'argano dal suo piedistallo, sfilando i fermi di sicurezza. K (Fig.7)

US

- check the condition of the pulley block and rotation of the pulley F (Fig.6);
- check the condition of the hook: to make sure it is not deformed, that it rotates freely and that the safety tab G (Fig. 6) is in working order;
- check the hook-up of the winch to the operating machine J (Fig. 7).

To use, from the parking position, unhook the winch from its frame, removing the safety catches. K (Fig.7)

NL

- controleer de takel en de draaiing van zijn kabelschijf F (Fig.6);
- controleer de staat van de haak: of deze niet vervormd is, of hij vrij draait en of zijn veiligheidssluiting efficiënt is G (Fig.6);
- controleer de aankoppeling van de lier aan de machine J (Fig.7).

Voor het gebruik de lier, vanuit zijn parkeerstand, van zijn staander haken door de beveiligingen eruit te trekken. K (Fig.7)

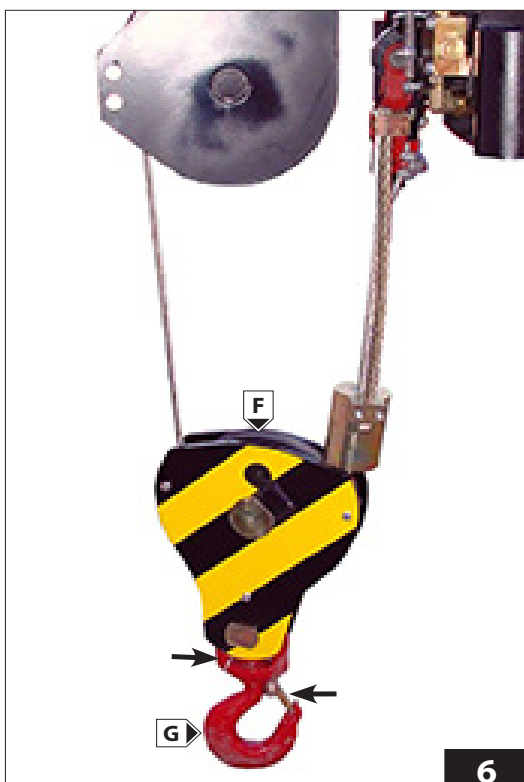

6



7



IT

MANUTENZIONE

- RIDUTTORE
- FUNE, PULEGGIA E CAPOCORDA
- BOZZELLO
- GANCIO
- FINE CORSA DISCESA FUNE
- FINE CORSA SALITA FUNE
- IMPIANTO IDRAULICO

US

MAINTENANCE

- REDUCTION GEAR
- ROPE, PULLEY AND CABLE TERMINAL
- PULLEY BLOCK
- HOOK
- ROPE DESCENT LIMIT SWITCH
- ROPE ASCENT LIMIT SWITCH
- HYDRAULIC SYSTEM

NL

ONDERHOUD

- REDUCTOR
- KABEL, KABELSCHIJF en KABELUI-
TEINDEN
- TAKEL
- HAAK
- EINDAANSLAG KABEL OMLAAG
- EINDAANSLAG KABEL OMHOOG
- HYDRAULISCH CIRCUIT

IT

RIDUTTORE

Una corretta lubrificazione consente un buon funzionamento e una lunga durata del riduttore.

Per accedere all'indicatore di livello o al tappo di rabbocco olio, occorre srotolare completamente la fune dal tamburo.

Controllare il livello dell'olio almeno una volta al mese B (Fig.8) e all'occorrenza rabboccare A (Fig.8) con olio dello stesso tipo di quello presente all'interno del riduttore (ISO VG 150).

Si consiglia l'utilizzo di olio per ingranaggi con additivazione EP con viscosità ISO VG, dipendente dalla temperatura di esercizio.

La prima sostituzione dell'olio deve essere effettuata dopo 100 ore di funzionamento, successivamente ogni 12 mesi o ogni 2000 ore di funzionamento.

Eseguire il cambio dell'olio con riduttore ancora caldo per facilitare un completo svuotamento.

Per scaricare l'olio, ruotare il tamburo del motore portando il tappo di rabbocco / scarico A (Fig.8a) verso il basso. Svitare il tappo A (Fig.8a) e scaricare completamente l'olio.

Ruotare il tamburo portando il foro di rabbocco/scarico verso l'alto A (Fig.8). Svitare il tappo di livello olio B (Fig.8); Rabboccare con olio nuovo e di tipo corretto fino a quando l'olio non fuoriesce da foro di livello B (Fig.8).(0,25 lt) Riavvitare i tappi e riavvolgere la fune.

US

REDUCTION GEAR

Correct lubrication allows proper working and longer life of the reduction gear.

To access the level indicator or oil topping up cap, the rope must be unwound completely from the drum.

Check the oil level at least once a month B (Fig.8) and if required, top up A (Fig.8) with oil of the same type as that present inside the reduction gear (ISO VG 150).

It is advisable to use oil for gears to which EP is added with viscosity ISO VG, depending on the operating temperature.

The first oil change must be after 100 hours of operation, then subsequently every 12 months or every 2000 hours of operation.

Change the oil with the reduction gear still hot to allow complete drainage.

To drain the oil, turn the engine drum so that the filler/drainage cap A (Fig. 8a) is facing downwards.

Unscrew cap A (Fig.8a) and drain out the oil completely.

Turn the drum to bring the topping up/drainage hole facing upwards A (Fig.8). Unscrew the oil level cap B (Fig.8).

Top up with fresh oil of the correct type until the oil flows out through the level hole B (Fig.8).(0.25 l).

Screw the cap back on and rewind the rope.

NL

REDUCTOR

Een correcte smering maakt een goede werking en een lange levensduur van de reductor mogelijk.

Om toegang te verkrijgen tot de oliepeilindicator of de oliebijvuldop, moet de kabel helemaal van de trommel gerold worden.

Controleer het oliepeil minstens eens per maand B (Fig.8) en indien nodig bijvullen A (Fig.8) met olie van hetzelfde soort als dat aanwezig is in de reductor (ISO VG 150).

Er wordt aangeraden olie voor tandwielen te gebruiken met additievering van EP met viscositeit ISO VG, afhankelijk van de bedrijfstemperatuur.

De eerste olieerversing moet na 100 werkuren plaatsvinden, daarna om de 12 maanden of om de 2000 werkuren.

Ververs de olie met nog warme reductor om een complete leging te vergemakkelijken.

Om de olie af te voeren, de trommel van de motor zodanig draaien dat de bijvul/aftapdop A (Fig.8a) naar beneden staat.

Draai de dop A (Fig.8a) los en laat alle olie weglopen.

Draai de trommel zodanig dat de bijvul/aftapopening naar boven staat A (Fig.8).

Draai de oliepeildop los B (Fig.8);

Bijvullen met nieuwe olie van het juiste type totdat de olie door de oliepeilopening naar buiten komt B (Fig.8) (0,25 l)

Draai de doppen weer vast en wikkel de kabel weer op.

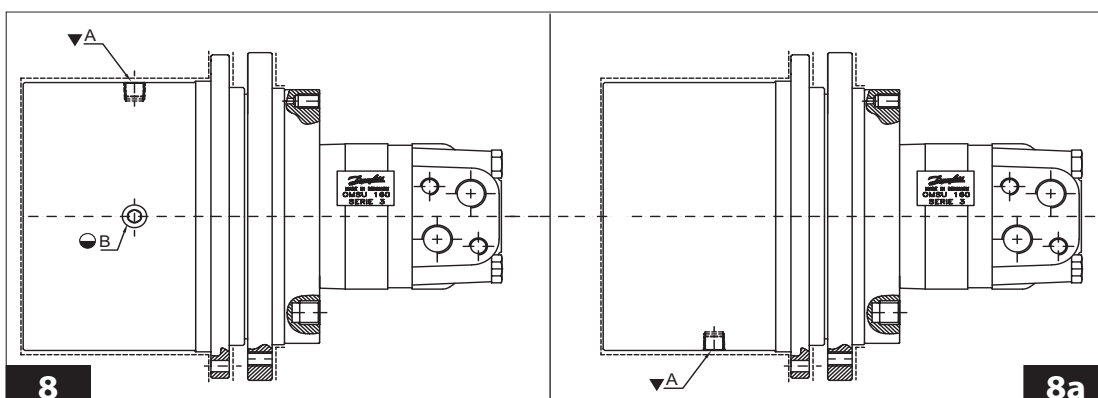
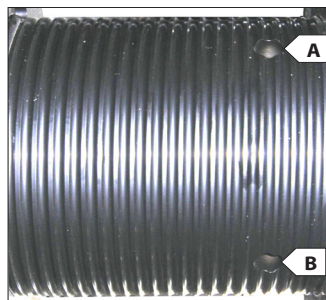

IT

FUNE, PULEGGIA e CAPOCORDA

Controllare giornalmente che la fune A (Fig.9) sia sempre in ottimo stato, che non ci siano filamenti rotti (Fig.9a) e che sia ben arrotolata sul tamburo B (Fig.9).

Altrimenti sostituirla con una nuova e dello stesso diametro e caratteristiche. Controllare la lubrificazione della fune, se necessita lubrificare con grasso industriale oppure olio sintetico anti-polvere.

Controllare giornalmente e mantenere lubrificato il perno C (Fig.9) su cui ruota la puleggia di guida D (Fig.9), che dovrà avere sempre un buono movimento di rotazione e di traslazione laterale. Se necessita, lubrificare con grasso al sapone di litio il perno.

Assicurarsi dell'integrità dei capocorda E (Fig.10) e dei suoi morsetti fermafune F (Fig.10).

US

ROPE, PULLEY AND CABLE TERMINAL

Check daily to make sure the rope A (Fig.9) is always in excellent condition, that it is not frayed (Fig.9a) and that it is wound perfectly around the drum B (Fig.9).

If necessary replace with a new rope having the same diameter and features. Check the lubrication of the rope, if necessary, lubricate with industrial grease or dust-proof synthetic oil.

Check the pin C (Fig. 9) on which the guide pulley D (Fig.9) rotates daily and keep it lubricated, it must always rotate and move transversely freely.

If necessary, lubricate the pin with lithium soap grease.

Ensure the integrity of the cable terminals E (Fig.10) and the rope retainer clamps F (Fig.10).

NL

KABEL, KABELSCHIJF en KABELUITEINDEN

Controleer dagelijks of de kabel A (Fig.9) in optimale staat verkeert, of er geen draden stuk zijn (Fig.9a) en of hij goed op de trommel gewonden is B (Fig.9).

Vervang hem anders door een nieuwe met dezelfde diameter en eigenschappen.

Controleer de smering van de kabel, indien nodig smeren met industrieel vet of synthetische olie tegen stof.

Controleer dagelijks de pen C (Fig.9) waarop de geleideschijven D (Fig.9) draait en houd ze gesmeerd. Deze moet altijd een goede draai beweging en zijwaartse schuif beweging behouden. Indien nodig, de pen invetten met lithiumzeepvet.

Controleer de staat van de kabeluiteinden E (Fig.10) en de kabelklemmen F (Fig.10).

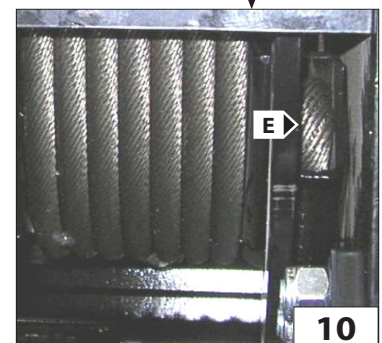
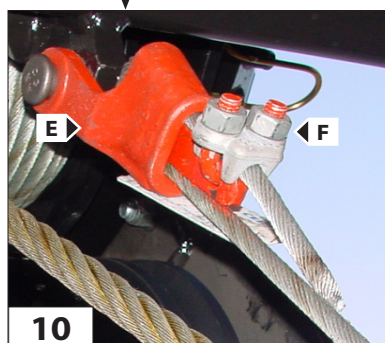
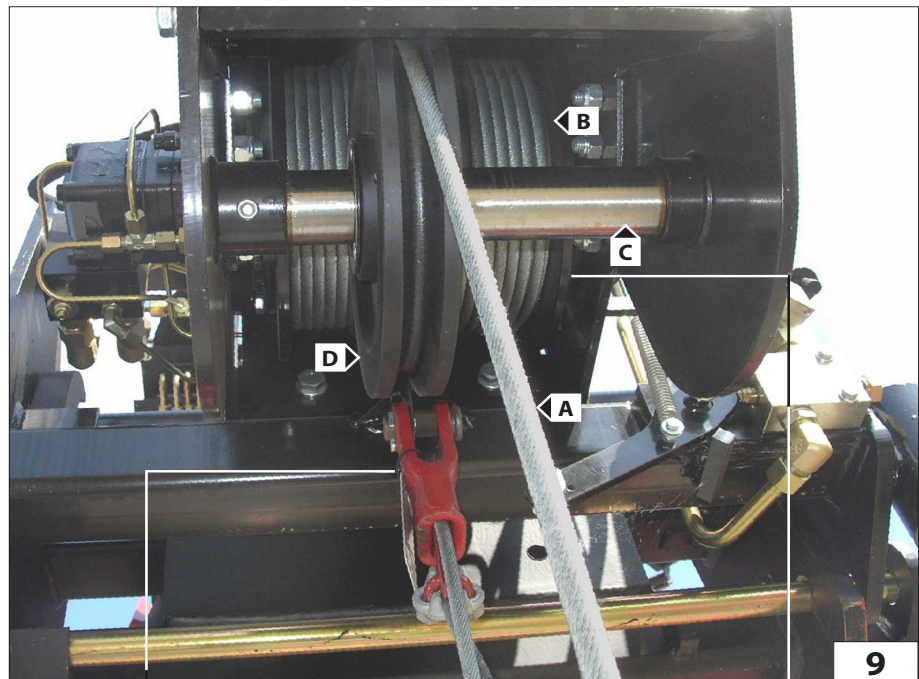
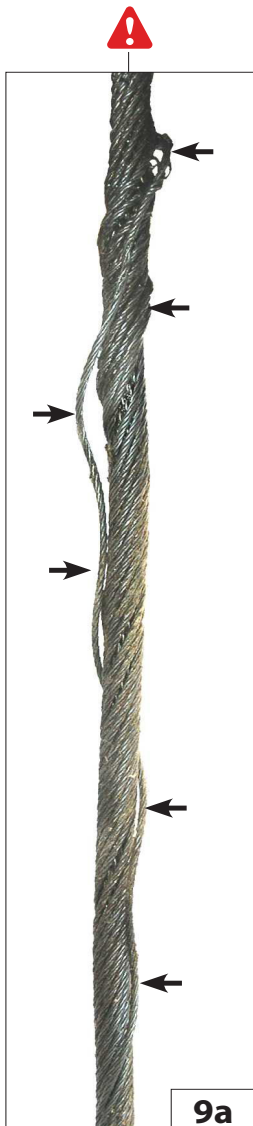

IT

BOZZELLO

Per una massima efficienza e sicurezza, mantenere intatta la struttura esterna H (Fig.11) e controllare che la puleggia L (Fig.12) ruoti correttamente sul suo perno M (Fig.12).

Se necessità, lubrificare con grasso al sapone di litio il perno M (Fig.11).

GANCIO

Per una massima efficienza mantenere lubrificata la vite di rotazione del gancio N (Fig.12).

Senza carico sospeso, il gancio deve sempre ruotare liberamente e con la sola pressione della mano P (Fig.12).

Controllare lo stato e l'efficienza della linguetta di sicurezza O (Fig.12).

Controllare lo stato e l'efficienza della linguetta di sicurezza O (Fig.12).

US

PULLEY BLOCK

For maximum efficiency and safety, keep the external structure H (Fig.11) intact and check to make sure the pulley L (Fig.12) rotates correctly on its pin M (Fig.12).

If necessary, lubricate the pin M (Fig.11) with lithium soap grease

HOOK

For maximum efficiency keep the hook rotation screw N (Fig. 12) lubricated.

Without a load hanging from it, the hook must always rotate freely when pushed slightly by hand P (Fig. 12).. Check the condition and efficiency of safety tab O (Fig. 12).

NL

TAKEL

Voor een maximale efficiëntie en veiligheid, de buitenste structuur intact houden H (Fig.11) en controleren of de kabelschijf L (Fig.12) goed op zijn pen draait M (Fig.12).

Indien nodig, de pen M (Fig.11) invetten met lithiumzeepvet.

HAAK

Voor een maximale efficiëntie de draaischroef van de haak N (Fig.12) gesmeerd houden.

Zonder hangende lading moet de haak altijd vrij kunnen draaien door er met de hand tegenaan te drukken P (Fig.12).

Controleer de staat en de efficiëntie van de veiligheidsluiting O (Fig.12).

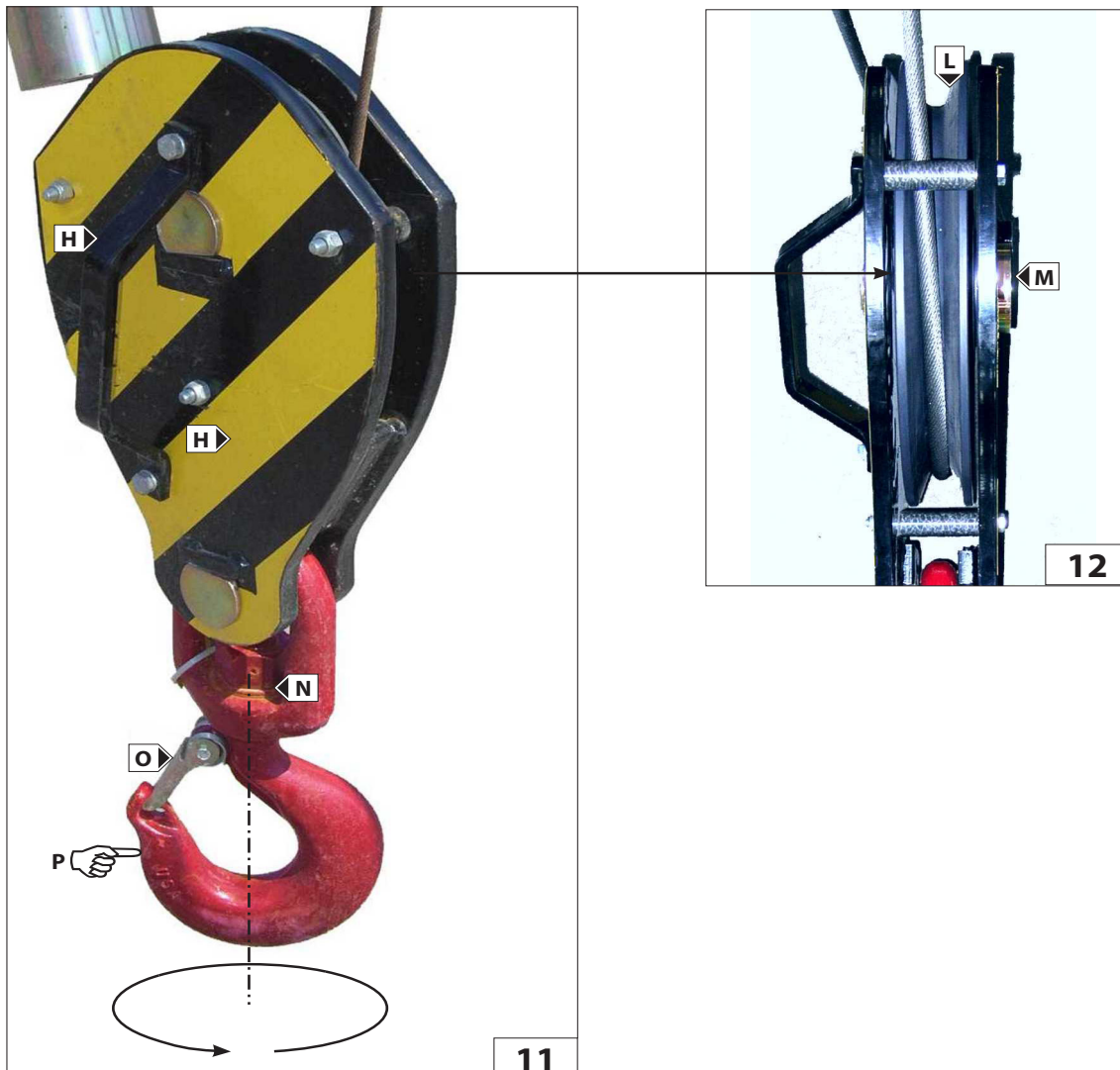

IT

FINE CORSA DISCESA FUNE (Fig.13)

Giornalmente per una massima efficienza mantenere sempre pulito il pistoncino e la valvola idraulica di sicurezza; controllare il serraggio dei raccordi e lo stato dei tubi.

Inoltre verificare l'integrità del leveraggio di contatto finecorsa discesa e la tenuta della sua molla.

FINE CORSA SALITA FUNE

Giornalmente per una massima efficienza mantenere sempre pulito il pistoncino e la valvola idraulica di sicurezza; controllare il serraggio dei raccordi e lo stato dei tubi.

Inoltre verificare l'integrità del leveraggio di contatto finecorsa salita e la tenuta della sua molla. (Fig.14)

IMPIANTO IDRAULICO (Fig.15)

Ispezionare giornalmente raccordi, valvole, tubi, per evitare eventuali perdite di olio che compromettano il rendimento e la durata dell'organo.

US

ROPE DESCENT LIMIT SWITCH (Fig. 13)

For maximum efficiency, check daily and keep the piston and hydraulic safety valve clean, check to make sure the connections are tightened properly and check the condition of the pipes. Also check the condition of the descent limit switch contact linkages and hold of its spring.

ROPE ASCENT LIMIT SWITCH

For maximum efficiency, check daily and keep the piston and hydraulic safety valve clean, check to make sure the connections are tightened properly and check the condition of the pipes. Also check the condition of the ascent limit switch contact linkages and hold of its spring. (Fig.14)

HYDRAULIC SYSTEM (Fig.15)

Check the connectors, valves, tubes daily to prevent oil leaks which could affect the performance and life of the winch.

NL

EINDAANSLAG KABEL OMLAAG (Fig.13)

Voor een maximale efficiëntie dagelijks altijd het zuigertje en het hydraulische veiligheidsventiel schoon houden; controleer of de verbindingen goed vast zitten en de staat van de leidingen. Controleer eveneens de staat van de hefbomen van de eindaanslag voor het dalen en zijn veer.

EINDAANSLAG KABEL OMHOOG

Voor een maximale efficiëntie dagelijks altijd het zuigertje en het hydraulische veiligheidsventiel schoon houden; controleer of de verbindingen goed vast zitten en de staat van de leidingen. Controleer eveneens de staat van de hefbomen van de eindaanslag voor het stijgen en zijn veer. (Fig.14)

HYDRAULISCHE INSTALLATIE (Fig.15)

Controleer dagelijks de verbindingstukken, kleppen en leidingen om eventuele olieklekken te voorkomen die het rendement en de levensduur van de lier zouden kunnen beïnvloeden.

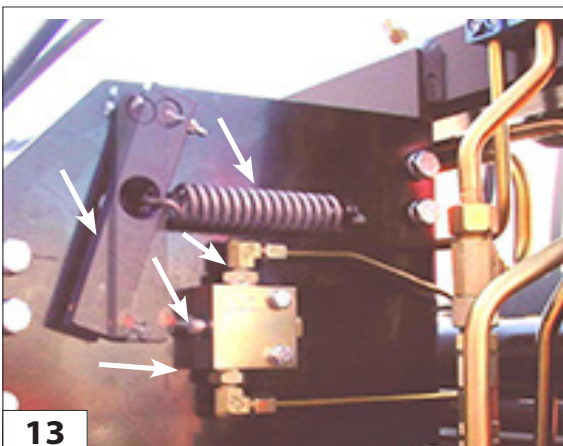

13

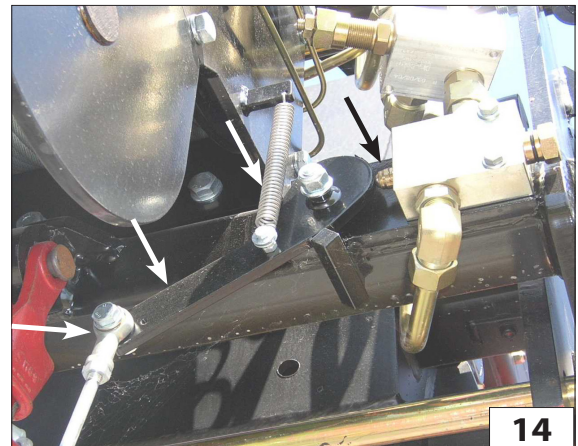

14

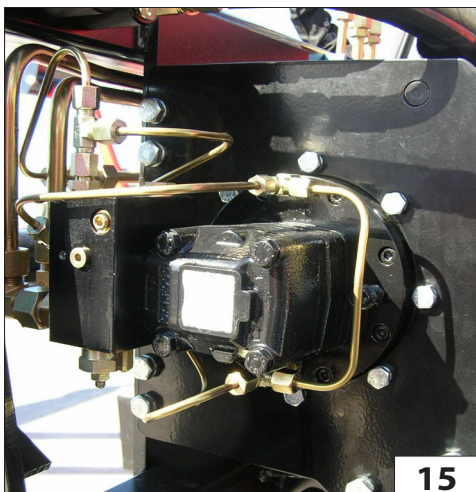

15

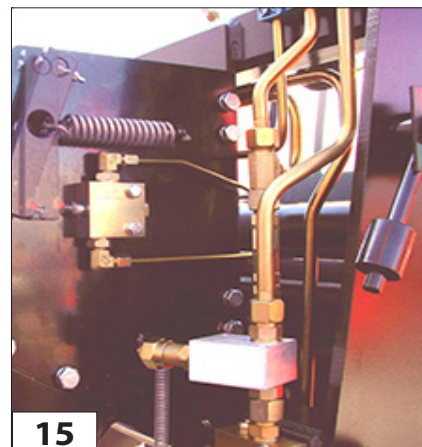

15

IT
SCHEMA IDRAULICO

US
HYDRAULIC DIAGRAM

NL
HYDRAULISCH SCHEMA

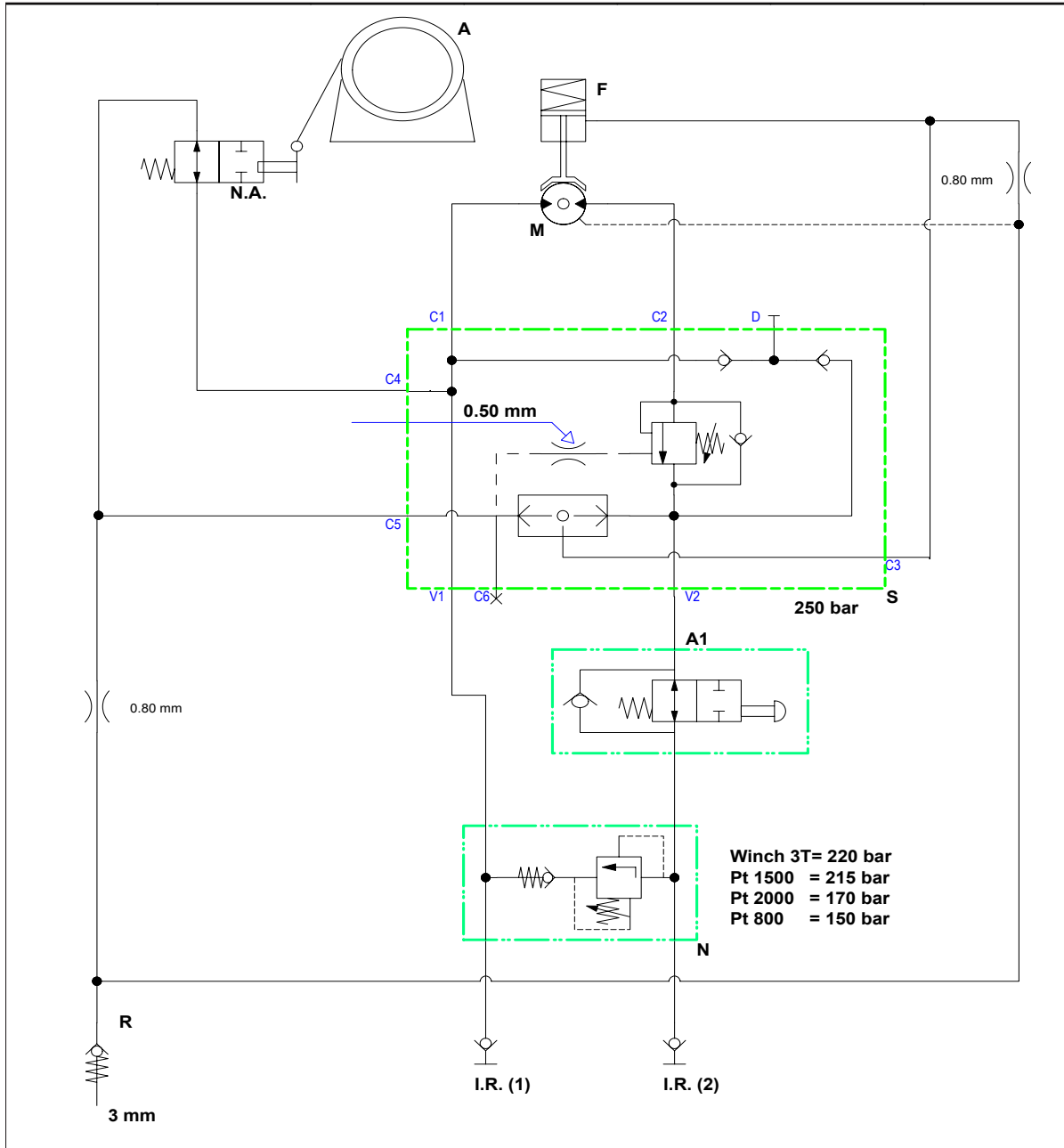

A = ARGANO
N.A. = MICRO MASSIMA DISCESA
R = SERBATOIO OLIO
I.R.1 = INNESTO RAPIDO
I.R.2 = INNESTO RAPIDO
A1 = MICRO MASSIMA SALITA
S = VALVOLA
N = VALVOLA MASSIMA PRESSIONE
M = MOTORE
F = FRENO

A = WINCH
N.A. = MAX. DESCENT MICRO SWITCH
R = OIL TANK
I.R.1 = QUICK-RELEASE COUPLING
I.R.2 = QUICK-RELEASE COUPLING
A1 = MAX. ASCENT MICRO SWITCH
S = VALVE
N = PRESSURE RELIEF VALVE
M = MOTOR
F = BRAKE

A = LIER
N.A. = MICRO MAXIMALE DALING
R = OLIETANK
I.R.1 = SNELKOPPELING
I.R.2 = SNELKOPPELING
A1 = MICRO MAXIMALE STIJGING
S = VENTIEL
N = MAXIMUMDRUKVENTIEL
M = MOTOR
F = REM



Questa pagina è intenzionalmente vuota
This page is left blank intentionally
Deze pagina is opzettelijk leeg gelaten



WINCH 4T

IT

ARGANO 4 T

Descrizione:

Argano idraulico 4t.

Caratteristiche:

- Tiro al 3° strato di 4000Kg.
- Velocità massima al 3° strato 21,5m/ min.
- Il tiro è in due taglie.
- La fune è di 53mt, diametro 12mm disposta su tre strati.
- Motore orbitale Sauer-Danfoss OMSU 80
- Riduttore epicicloidale con freno negativo a dischi in bagno d'olio.
- Il tamburo è filettato e dotato di un rullo pressa fune in modo da assicurare sempre un corretto avvolgimento della fune.
- Presenza di un guida fune che migliora ulteriormente l'avvolgimento della fune sul tamburo.
- Classificazione ISO 4301/1: T4,L2,M4.

Sicurezza:

- Fine corsa discesa idraulico positivo.
- Fine corsa salita idraulico positivo.

US

WINCH 4 T

Description:

4t Hydraulic winch

Features:

- Pull at 3rd layer 4000 kg.
- Maximum speed at 3rd layer 21.5m/ min.
- The pull is in two sheaves.
- The rope is 53 m long, 12mm diameter arranged in three layers.
- Sauer-Danfoss OMSU 80 orbital motor
- Planetary drive with negative oil bath disk brake
- The drum is threaded and provided with a rope press roller in order to always ensure correct winding of the rope.
- Presence of a rope guide which further improves the winding of the rope on the drum.
- ISO 4301/1 Classification: T4, L2, M4.

Safety devices:

- Positive hydraulic descent limit switch.
- Positive hydraulic ascent limit switch.

NL

WINCH 4 T

Beschrijving:

Hydraulische lier 4t

Kenmerken:

- Trekkracht 3de laag 4000 kg.
- Maximumsnelheid 3de laag 21,5 m/ min.
- Kabel dubbel gebruikt.
- De kabel is 53 m, diameter 12 mm in drie lagen.
- Sauer-Danfoss OMSU 80 orbitmotor
- Planetaire reductor met negatieve schijvenrem in oliebad.
- De trommel is gegleefd en voorzien van een kabelandrukrol voor een altijd correcte opwikkeling van de kabel.
- Aanwezigheid van een kabelgeleider voor een nog betere opwikkeling van de kabel op de trommel.
- Classificatie ISO 4301/1: T4,L2,M4.

Beschermingen:

- Positieve hydraulische eindaanslag daling.
- Positieve hydraulische eindaanslag stijging.





[kg] (lb)	[t] (t)	[mm] (in) x [m] (ft)	[m/min] [ft/min]	[bar] (psi)	[mm] (in)												[kg] (lb)
				P max													
4000 (8818)	5 (5)	∅ 12 (0,5) x 53 (174)	21,5 (70)	275 (3988)	A	B	C	D	E	F	G	H	I	L	M	N	510 (1124)
					1810 (71)	900 (35)	557 (22)	814 (32)	353 (14)	320 (12)	838 (33)	126 (5)	750 (29)	15 (0,6)	680 (27)	200 (8)	

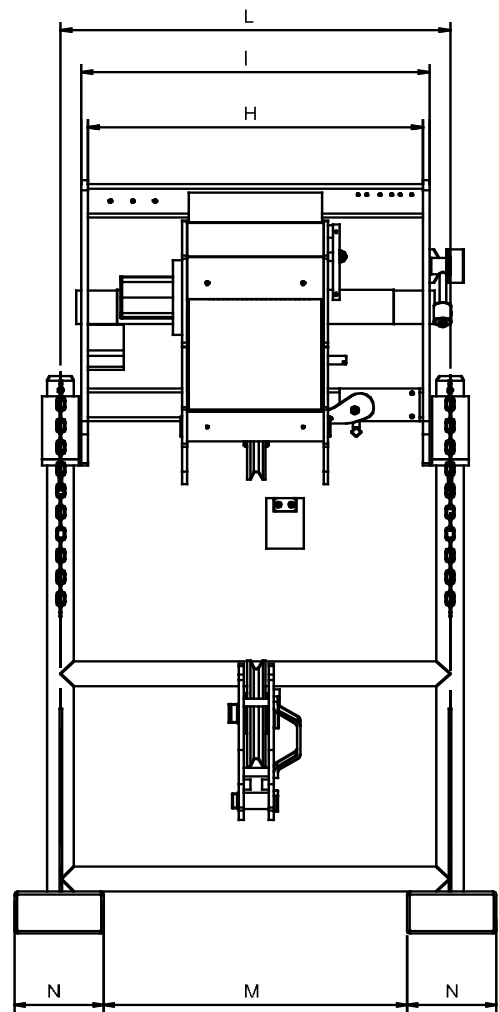
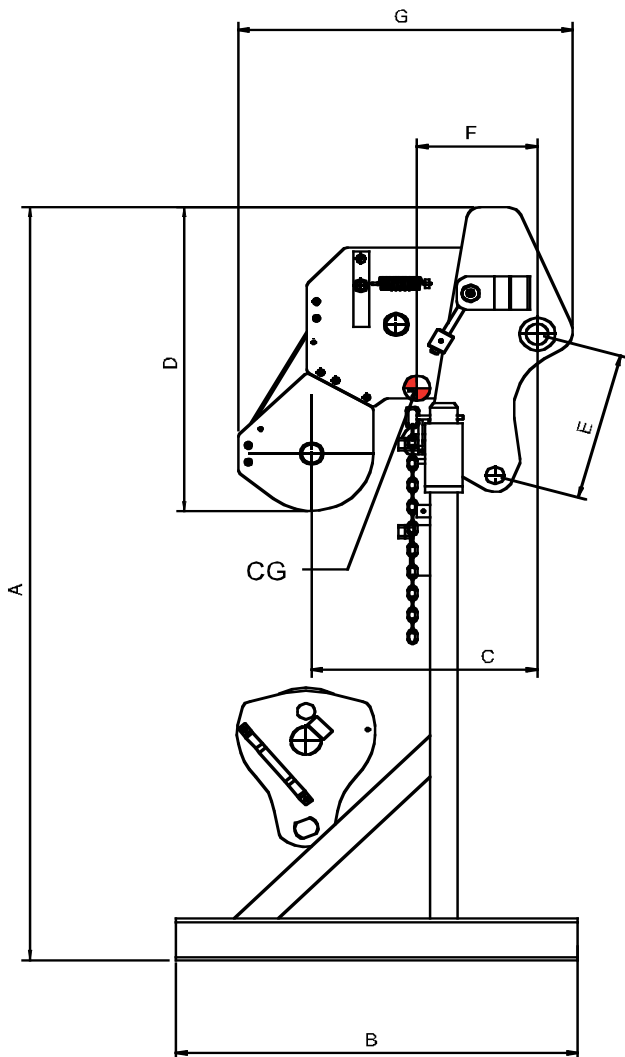

IT

MESSA IN SERVIZIO E UTILIZZO

Per la vostra sicurezza, prima di iniziare un ciclo di lavoro, attenersi alle Istruzioni obbligatorie di verifica e controllo:

- verificare l'integrità della struttura esterna dell'argano.
- verificare il corretto collegamento idraulico degli innesti rapidi 1, 2, Drenaggio e lo stato dei tubi flessibili (Fig.1);
- controllare il corretto funzionamento del fine corsa discesa fune H (Fig.2);
- controllare il corretto funzionamento del fine corsa salita fune L (Fig.2);
- controllare lo stato della fune e il corretto avvolgimento sul tamburo A (Fig.3);
- controllare il corretto movimento laterale e di rotazione della puleggia di guida fune B (Fig.3);
- controllare lo stato dei capocorda C (Fig.4) e E (Fig.5);

US

STARTING UP AND USE

For your safety, before starting a work cycle, follow the Compulsory instructions for inspection and control:

- check to make sure the external structure of the winch is intact.
- Check to ensure the correct hydraulic connection of quick-release couplings 1, 2, drainage and the condition of the hose pipes (Fig.1);
- check to ensure correct working of the rope descent limit switch H (Fig.2);
- check to ensure correct working of the rope ascent limit switch L (Fig.2);
- check the condition of the rope and that it is wound correctly on the drum A (Fig.3);
- check the correct lateral movement and rotation of the rope guide pulley B (Fig.3);
- check the condition of cable terminals C (Fig.4) and E (Fig.5);

NL

INBEDRIJFSTELLING EN GEBRUIK

Houd u, voor uw eigen veiligheid, voor met een werkcyclus aan te vangen, aan de **verplichte controle-instructies**:

- controleer of de buitenste structuur van de lier intact is.
- controleer of de hydraulische verbinding van de snelkoppelingen 1, 2, Afvoer en de staat van de slangen in orde zijn (Fig.1);
- controleer de werking van de eindslag kabel omlaag H (Fig.2);
- controleer de werking van de eindslag kabel omhoog L (Fig.2);
- controleer de staat van de kabel en de opwikkeling op de trommel A (Fig.3);
- controleer de zijdelingse beweging en draai beweging van het kabelgeleidewiel B (Fig.3);
- controleer de staat van het kabeluiteinde C (Fig.4) en E (Fig.5);

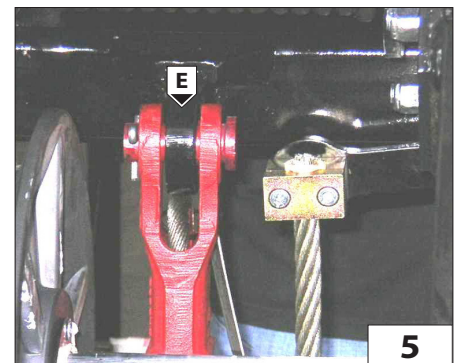
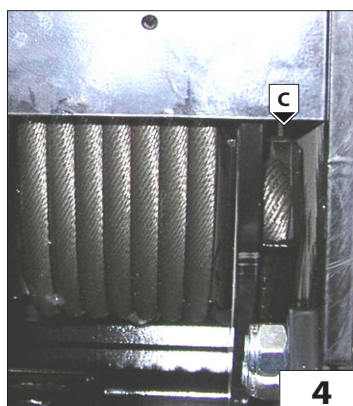
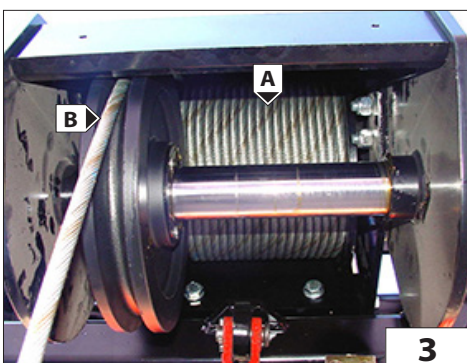
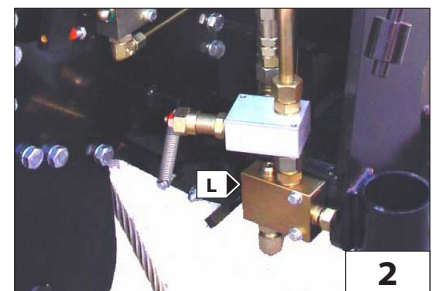
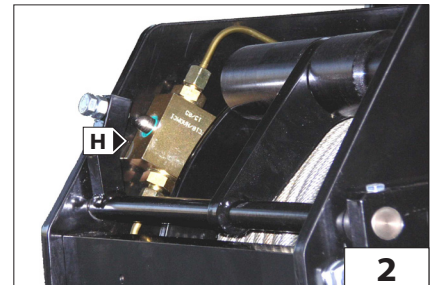
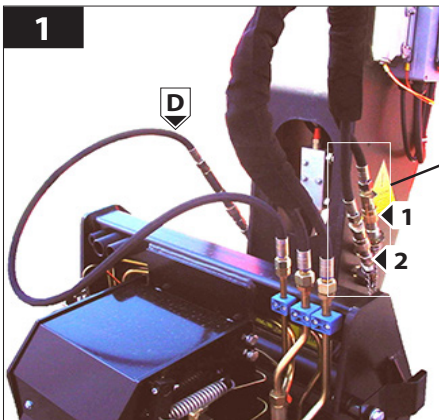

IT

- verificare l'integrità del bozzello e la rotazione della sua puleggia F (Fig.6);
- verificare lo stato del gancio: che non sia deformato, che ruoti liberamente e che la linguetta di sicurezza sia efficiente G (Fig.6);
- controllare l'aggancio dell'argano alla macchina operatrice J (Fig.7).

Per l'utilizzo, dalla posizione di parcheggio, sganciare l'argano dal suo piedistallo, sfilando i fermi di sicurezza. K (Fig.7)

US

- check the condition of the pulley block and rotation of the pulley F (Fig.6);
- check the condition of the hook: to make sure it is not deformed, that it rotates freely and that the safety tab G (Fig. 6) is in working order;
- check the hook-up of the winch to the operating machine J (Fig.7).

To use, from the parking position, unhook the winch from its frame, removing the safety catches. K (Fig.7)

NL

- controleer de takel en de draaiing van zijn kabelschijf F (Fig.6);
- controleer de staat van de haak: of deze niet vervormd is, of hij vrij draait en of zijn veiligheidssluiting efficiënt is G (Fig.6);
- controleer de aankoppeling van de lier aan de machine J (Fig.7).

Voor het gebruik de lier, vanuit zijn parkeerstand, van zijn staander haken door de beveiligingen eruit te trekken. K (Fig.7)

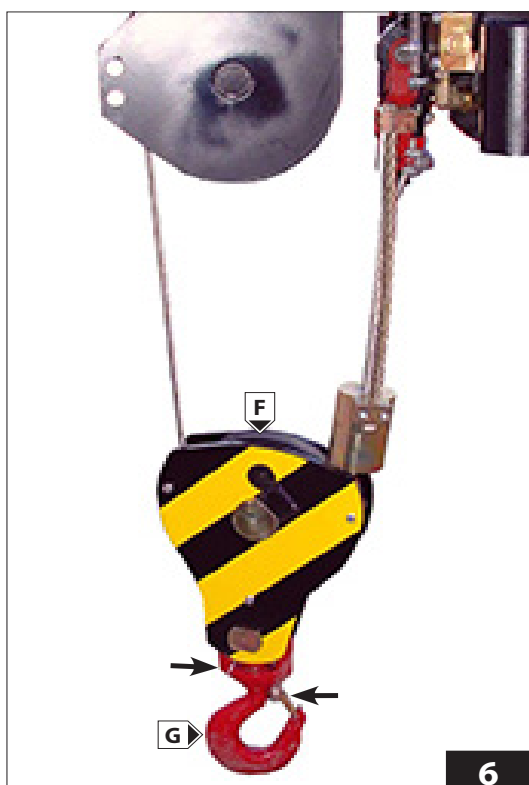



IT

MANUTENZIONE

- RIDUTTORE
- FUNE, PULEGGIA E CAPOCORDA
- BOZZELLO
- GANCIO
- FINE CORSA DISCESA FUNE
- FINE CORSA SALITA FUNE
- IMPIANTO IDRAULICO

US

MAINTENANCE

- REDUCTION GEAR
- ROPE, PULLEY AND CABLE TERMINAL
- PULLEY BLOCK
- HOOK
- ROPE DESCENT LIMIT SWITCH
- ROPE ASCENT LIMIT SWITCH
- HYDRAULIC SYSTEM

NL

ONDERHOUD

- REDUCTOR
- KABEL, KABELSCHIJF en KABELUI-
TEINDEN
- TAKEL
- HAAK
- EINDAANSLAG KABEL OMLAAG
- EINDAANSLAG KABEL OMHOOG
- HYDRAULISCH CIRCUIT

IT

RIDUTTORE

Una corretta lubrificazione consente un buon funzionamento e una lunga durata del riduttore.

Per accedere all'indicatore di livello o al tappo di rabbocco olio, occorre srotolare completamente la fune dal tamburo.

Controllare il livello dell'olio ogni 100 ore A (Fig.8b) e all'occorrenza rabboccare A (Fig.8b) con olio dello stesso tipo di quello presente all'interno del riduttore (SHELL SPIRAX HD80 W90).

Si consiglia l'utilizzo di olio per ingranaggi con additivazione EP con viscosità SAE 80W/90 oppure SAE 85W/140.

La prima sostituzione dell'olio deve essere effettuata dopo 150 ore di funzionamento, successivamente ogni 1000 ore di funzionamento.

Eseguire il cambio dell'olio con riduttore ancora caldo per facilitare un completo svuotamento.

Per scaricare l'olio, ruotare il tamburo del motore portando il tappo di rabbocco / scarico A (Fig.8a) verso il basso. Svitare il tappo A (Fig.8a) e scaricare completamente l'olio.

Ruotare il tamburo portando il foro di rabbocco/scarico sull'asse orizzontale A (Fig.8b).

Rabboccare con olio nuovo e di tipo corretto fino a quando l'olio non fuoriesce da foro di livello A (Fig.8b) (1,3 lt).

Riavvitare i tappi e riavvolgere la fune.

US

REDUCTION GEAR

Correct lubrication allows proper working and longer life of the reduction gear.

To access the level indicator or oil topping up cap, the rope must be unwound completely from the drum.

Check the oil level at least every 100 hours A (Fig.8b) and if required, top up A (Fig.8b) with oil of the same type as that present inside the reduction gear (SHELL SPIRAX HD80 W90).

Use gear oil with additive EP with viscosity SAE 80W/90 or SAE 85W/140.

The first oil change must be after 150 hours of operation, then subsequently every 1000 hours of operation.

Change the oil with the reduction gear still hot to allow complete drainage.

To drain the oil, turn the engine drum so that the filler/drainage cap A (Fig. 8a) is facing downwards.

Unscrew cap A (Fig.8a) and drain out the oil completely.

Turn the drum to bring the topping up/drainage hole horizontal A (Fig.8b).

Top up with fresh oil of the correct type until the oil flows out through the level hole A (Fig.8b) (1.3 l).

Screw the cap back on and rewind the rope.

NL

REDUCTOR

Een correcte smering maakt een goede werking en een lange levensduur van de reductor mogelijk.

Om toegang te verkrijgen tot de oliepeilindicator of de oliebijvuldop, moet de kabel helemaal van de trommel gerold worden.

Controleer het oliepeil om de 100 uren A (Fig.8b) en indien nodig bijvullen A (Fig.8b) met olie van hetzelfde soort als dat aanwezig is in de reductor (SHELL SPIRAX HD80 W90).

Er wordt aangeraden olie voor tandwielen te gebruiken met additievering van EP met viscositeit SAE 80W/90 of SAE 85W/140.

De eerste olieversing moet na 150 werkuren plaatsvinden, daarna om de 1000 werkuren.

Ververs de olie met nog warme reductor om een complete leging te vergemakkelijken.

Om de olie af te voeren, de trommel van de motor zodanig draaien dat de bijvul/aftapdop A (Fig.8a) naar beneden staat.

Draai de dop A (Fig.8a) los en laat alle olie weglopen.

Draai de trommel zodanig dat de bijvul-/aftapopening op de horizontale as staat A (Fig.8b).

Bijvullen met nieuwe olie van het juiste type totdat de olie door de oliepeilopening naar buiten komt A (Fig.8b) (1,3 l)

Draai de doppen weer vast en wikkel de kabel weer op.

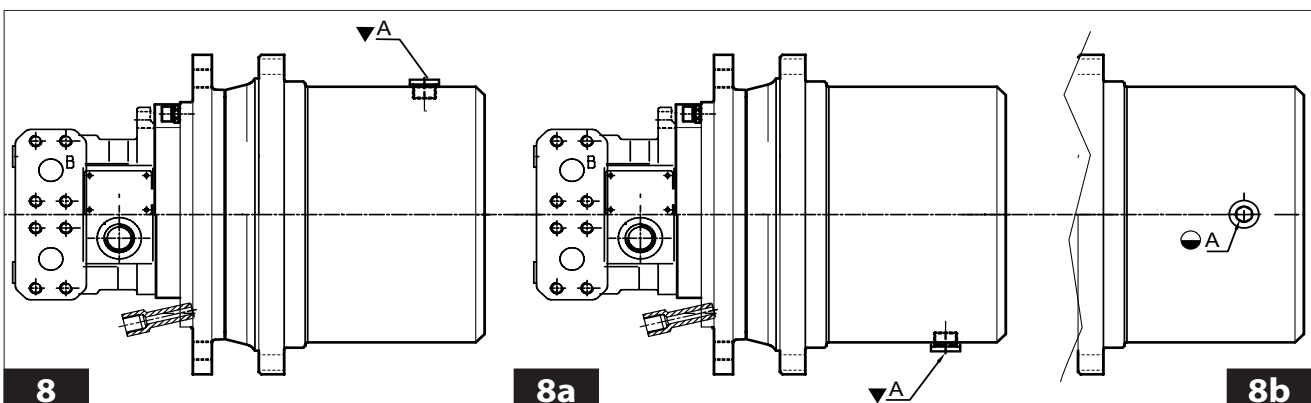
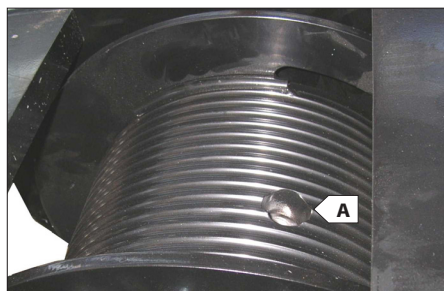

IT

FUNE, PULEGGIA e CAPOCORDA

Controllare giornalmente che la fune A (Fig.9) sia sempre in ottimo stato, che non ci siano filamenti rotti (Fig.9a) e che sia ben arrotolata sul tamburo B (Fig.9).

Altrimenti sostituirla con una nuova e dello stesso diametro e caratteristiche. Controllare la lubrificazione della fune, se necessita lubrificare con grasso industriale oppure olio sintetico anti-polvere.

Controllare giornalmente e mantenere lubrificato il perno C (Fig.9) su cui ruota la puleggia di guida D (Fig.9), che dovrà avere sempre un buono movimento di rotazione e di traslazione laterale. Se necessita, lubrificare con grasso al sapone di litio il perno.

Assicurarsi dell'integrità dei capocorda E (Fig.10) e dei suoi morsetti fermafune F (Fig.10).

US

ROPE, PULLEY AND CABLE TERMINAL

Check daily to make sure the rope A (Fig.9) is always in excellent condition, that it is not frayed (Fig.9a) and that it is wound perfectly around the drum B (Fig.9).

If necessary replace with a new rope having the same diameter and features. Check the lubrication of the rope, if necessary, lubricate with industrial grease or dust-proof synthetic oil.

Check the pin C (Fig. 9) on which the guide pulley D (Fig.9) rotates daily and keep it lubricated, it must always rotate and move transversely freely. If necessary, lubricate the pin with lithium soap grease.

Ensure the integrity of the cable terminals E (Fig.10) and the rope retainer clamps F (Fig.10).

NL

KABEL, KABELSCHIJF en KABELUITEINDEN

Controleer dagelijks of de kabel A (Fig.9) in optimale staat verkeert, of er geen draden stuk zijn (Fig.9a) en of hij goed op de trommel gewonden is B (Fig.9).

Vervang hem anders door een nieuwe met dezelfde diameter en eigenschappen.

Controleer de smering van de kabel, indien nodig smeren met industrieel vet of synthetische olie tegen stof.

Controleer dagelijks de pen C (Fig.9) waarop de geleideschijven D (Fig.9) draait en houd ze gesmeerd. Deze moet altijd een goede draai beweging en zijwaartse schuif beweging behouden. Indien nodig, de pen invetten met lithiumzeepvet.

Controleer de staat van de kabeluiteinden E (Fig.10) en de kabelklemmen F (Fig.10).

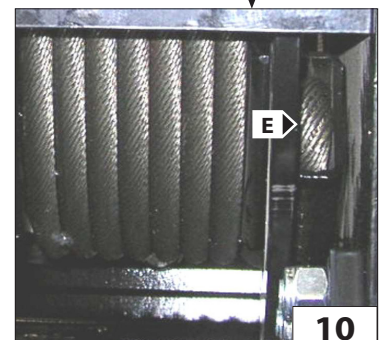
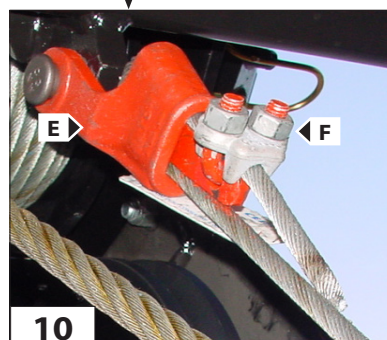
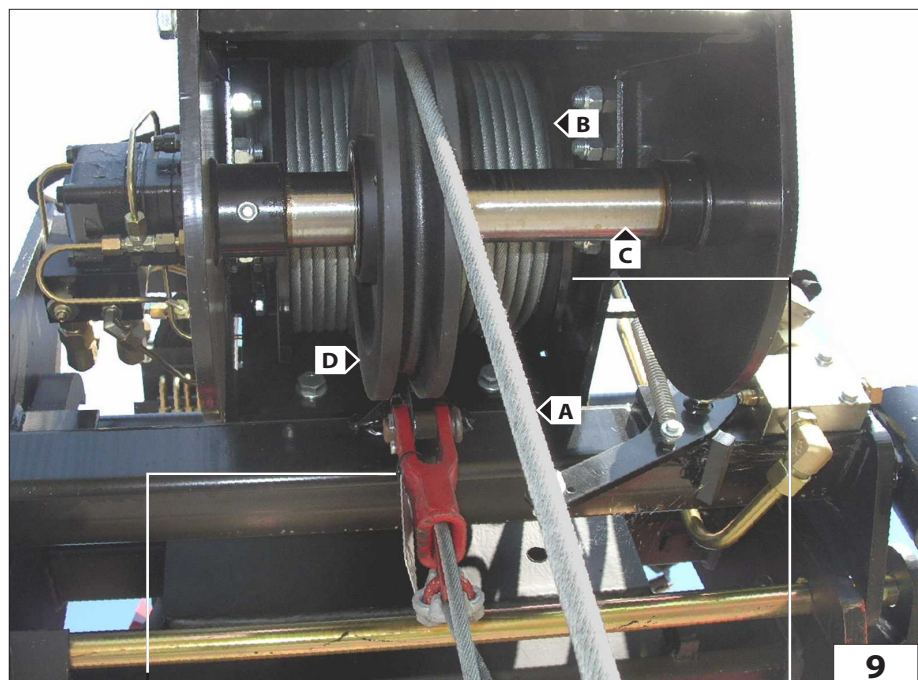
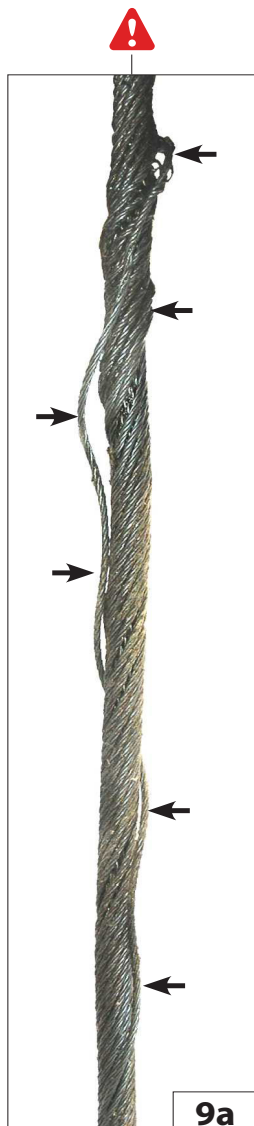

IT

BOZZELLO

Per una massima efficienza e sicurezza, mantenere intatta la struttura esterna H (Fig.11) e controllare che la puleggia L (Fig.12) ruoti correttamente sul suo perno M (Fig.12) .

Se necessità, lubrificare con grasso al sapone di litio il perno M (Fig.11).

GANCIO

Per una massima efficienza mantenere lubrificata la vite di rotazione del gancio N (Fig.12).

Senza carico sospeso, il gancio deve sempre ruotare liberamente e con la sola pressione della mano P (Fig.12). Controllare lo stato e l'efficienza della linguetta di sicurezza O (Fig.12).

US

PULLEY BLOCK

For maximum efficiency and safety, keep the external structure H (Fig.11) intact and check to make sure the pulley L (Fig.12) rotates correctly on its pin M (Fig.12) .

If necessary, lubricate the pin M (Fig. 11) with lithium soap grease

HOOK

For maximum efficiency keep the hook rotation screw N (Fig. 12) lubricated.

Without a load hanging from it, the hook must always rotate freely when pushed slightly by hand P (Fig. 12).. Check the condition and efficiency of safety tab O (Fig. 12).

NL

TAKEL

Voor een maximale efficiëntie en veiligheid, de buitenste structuur intact houden H (Fig.11) en controleren of de kabelschijf L (Fig.12) goed op zijn pen draait M (Fig.12).

Indien nodig, de pen M (Fig.11) invetten met lithiumzeepvet.

HAAK

Voor een maximale efficiëntie de draaischroef van de haak N (Fig.12) gesmeerd houden.

Zonder hangende lading moet de haak altijd vrij kunnen draaien door er met de hand tegenaan te drukken P (Fig.12).

Controleer de staat en de efficiëntie van de veiligheidsluiting O (Fig.12).

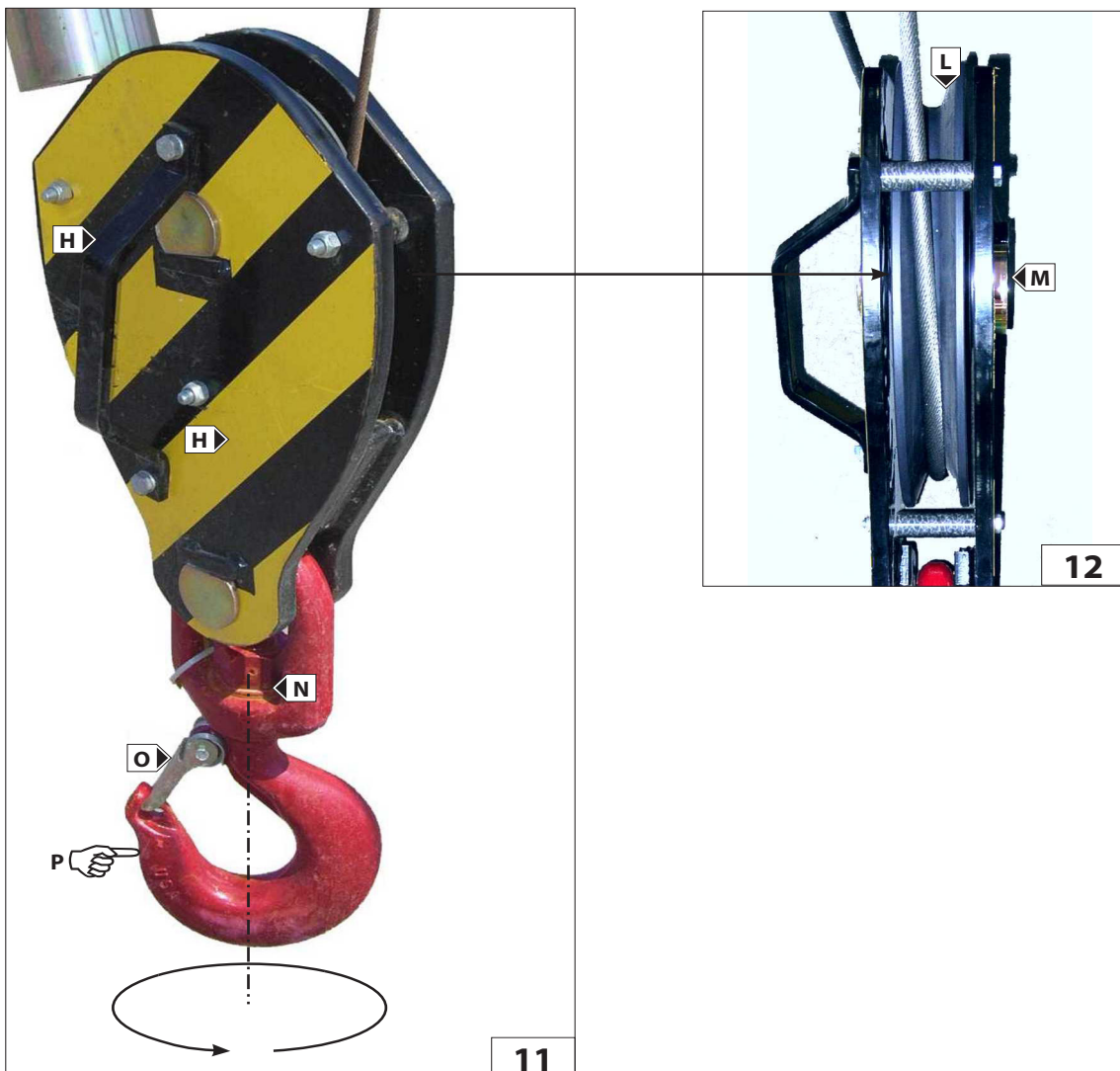

IT

FINE CORSA DISCESA FUNE (Fig.13)

Giornalmente per una massima efficienza mantenere sempre pulito il pistoncino e la valvola idraulica di sicurezza; controllare il serraggio dei raccordi e lo stato dei tubi. Inoltre verificare l'integrità del leveraggio di contatto finecorsa discesa e la tenuta della sua molla.

FINE CORSA SALITA FUNE

Giornalmente per una massima efficienza mantenere sempre pulito il pistoncino e la valvola idraulica di sicurezza; controllare il serraggio dei raccordi e lo stato dei tubi. Inoltre verificare l'integrità del leveraggio di contatto finecorsa salita e la tenuta della sua molla. (Fig.14)

IMPIANTO IDRAULICO (Fig.15)

Ispezionare giornalmente raccordi, valvole, tubi, per evitare eventuali perdite di olio che compromettano il rendimento e la durata dell'argano.

US

ROPE DESCENT LIMIT SWITCH (Fig. 13)

For maximum efficiency, check daily and keep the piston and hydraulic safety valve clean, check to make sure the connections are tightened properly and check the condition of the pipes. Also check the condition of the descent limit switch contact linkages and hold of its spring.

ROPE ASCENT LIMIT SWITCH

For maximum efficiency, check daily and keep the piston and hydraulic safety valve clean, check to make sure the connections are tightened properly and check the condition of the pipes. Also check the condition of the ascent limit switch contact linkages and hold of its spring. (Fig.14)

HYDRAULIC SYSTEM (Fig.15)

Check the connectors, valves, tubes daily to prevent oil leaks which could affect the performance and life of the winch.

NL

EINDAANSLAG KABEL OMLAAG (Fig.13)

Voor een maximale efficiëntie dagelijks altijd het zuigertje en het hydraulische veiligheidsventiel schoon houden; controleer of de verbindingen goed vast zitten en de staat van de leidingen. Controleer eveneens de staat van de hefboomen van de eindaanslag voor het dalen en zijn veer.

EINDAANSLAG KABEL OMHOOG

Voor een maximale efficiëntie dagelijks altijd het zuigertje en het hydraulische veiligheidsventiel schoon houden; controleer of de verbindingen goed vast zitten en de staat van de leidingen. Controleer eveneens de staat van de hefboomen van de eindaanslag voor het stijgen en zijn veer. (Fig.14)

HYDRAULISCHE INSTALLATIE (Fig.15)

Controleer dagelijks de verbindingstukken, kleppen en leidingen om eventuele olieklekken te voorkomen die het rendement en de levensduur van de lier zouden kunnen beïnvloeden.

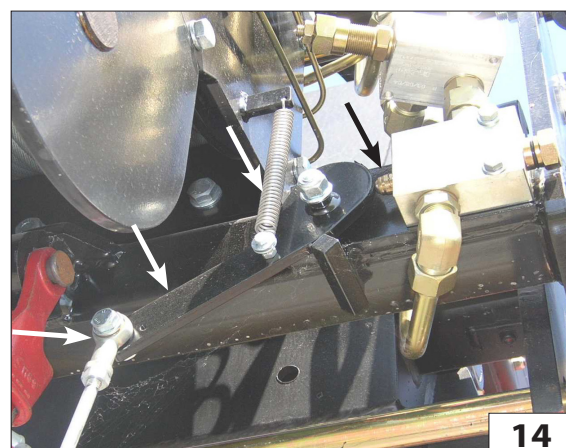
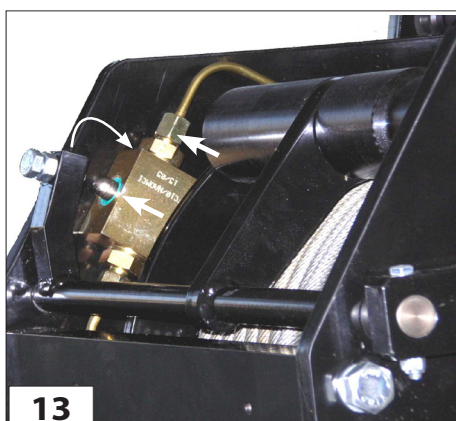
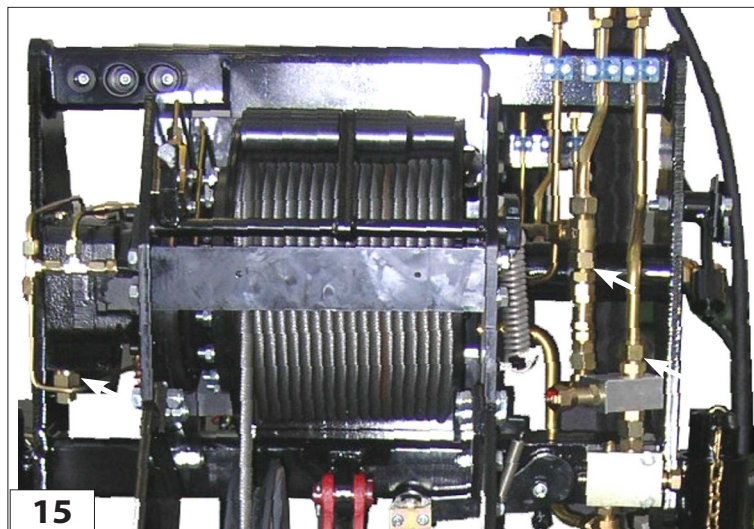

IT

US

NL

SCHEMA IDRAULICO

HYDRAULIC DIAGRAM

HYDRAULISCH SCHEMA

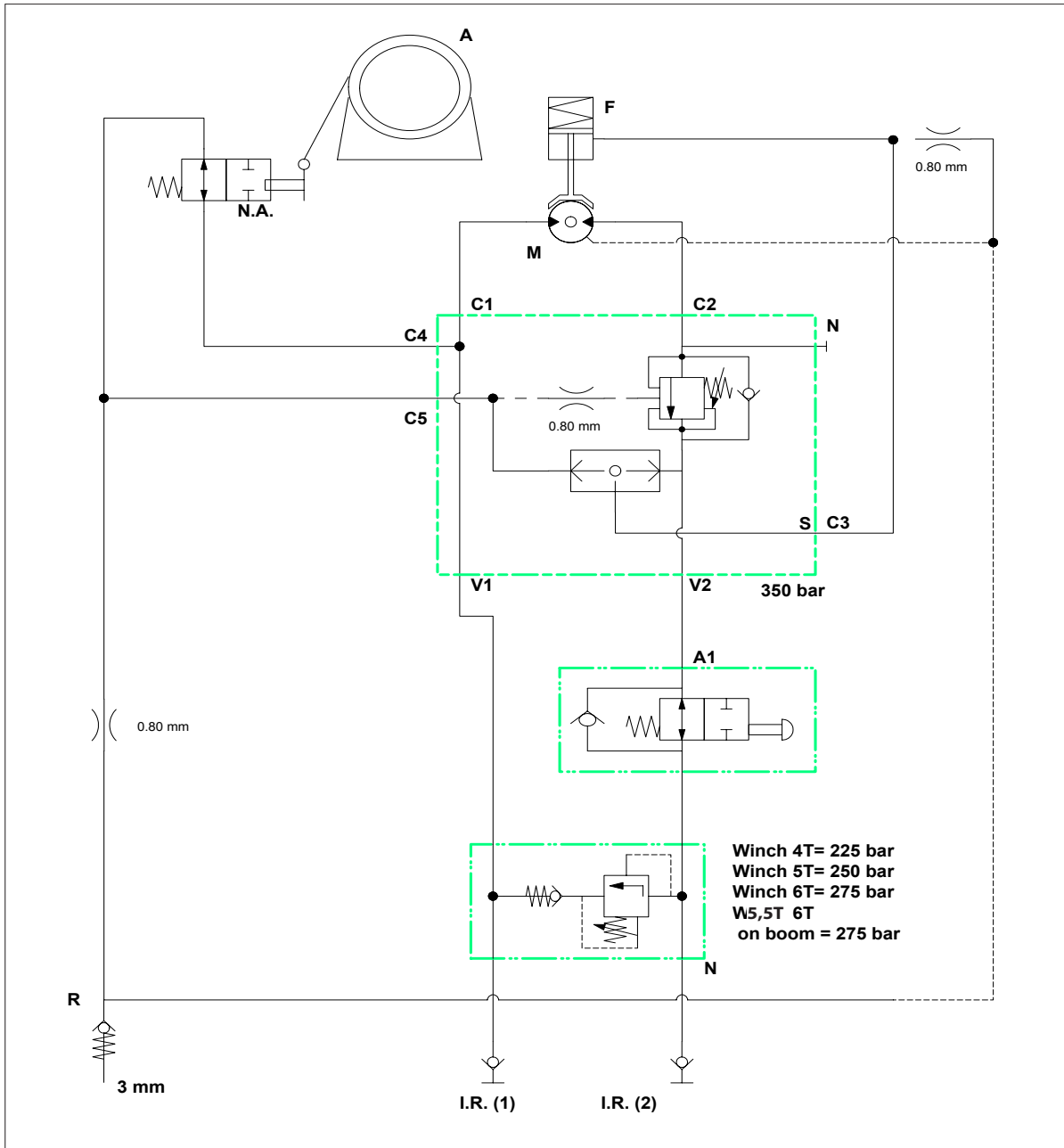

A = ARGANO
N.A. = MICRO MASSIMA DISCESA
R = SERBATOIO OLIO
I.R.1 = INNESTO RAPIDO
I.R.2 = INNESTO RAPIDO
A1 = MICRO MASSIMA SALITA
S = VALVOLA
N = VALVOLA MASSIMA PRESSIONE
M = MOTORE
F = FRENO

A = WINCH
N.A. = MAX. DESCENT MICRO SWITCH
R = OIL TANK
I.R.1 = QUICK-RELEASE COUPLING
I.R.2 = QUICK-RELEASE COUPLING
A1 = MAX. ASCENT MICRO SWITCH
S = VALVE
N = PRESSURE RELIEF VALVE
M = MOTOR
F = FRENO

A = LIER
N.A. = MICRO MAXIMALE DALING
R = OLJETANK
I.R.1 = SNELKOPPELING
I.R.2 = SNELKOPPELING
A1 = MICRO MAXIMALE STIJGING
S = VENTIEL
N = MAXIMUMDRUKVENTIEL
M = MOTOR
F = REM



Questa pagina è intenzionalmente vuota
This page is left blank intentionally
Deze pagina is opzettelijk leeg gelaten



WINCH 5T

IT

ARGANO 5 T

Descrizione:

Argano idraulico 5t.

Caratteristiche:

- Tiro al 3° strato di 5000Kg.
- Velocità massima al 3° strato 21,5mt/ min.
- Il tiro è in due taglie.
- La fune è di 53mt, diametro 12mm disposta su tre strati.
- Motore orbitale Sauer-Danfoss OMSU 80
- Riduttore epicicloidale con freno negativo a dischi in bagno d'olio.
- Il tamburo è filettato e dotato di un rullo pressa fune in modo da assicurare sempre un corretto avvolgimento della fune.
- Presenza di un guida fune che migliora ulteriormente l'avvolgimento della fune sul tamburo.
- Classificazione ISO 4301/1: T4,L2,M4.

Sicurezze:

- Fine corsa discesa idraulico positivo.
- Fine corsa salita idraulico positivo.

US

WINCH 5 T

Description:

5t Hydraulic winch

Features:

- Pull at 3rd layer 5000 kg.
- Maximum speed at 3^o layer 21.5m/ min.
- The pull is in two sheaves.
- The rope is 53 m long, 12mm diameter arranged in three layers.
- Sauer-Danfoss OMSU 80 orbital motor
- Planetary drive with negative oil bath disk brake
- The drum is threaded and provided with a rope press roller in order to always ensure correct winding of the rope.
- Presence of a rope guide which further improves the winding of the rope on the drum.
- ISO 4301/1 Classification: T4, L2, M4.

Safety devices:

- Positive hydraulic descent limit switch.
- Positive hydraulic ascent limit switch.

NL

WINCH 5 T

Beschrijving:

Hydraulische lier 5t

Kenmerken:

- Trekkracht 3de laag 5000 kg.
- Maximalsnelheid 3de laag 21,5 m/ min.
- Kabel dubbel gebruikt.
- De kabel is 53 m, diameter 12 mm in drie lagen.
- Sauer-Danfoss OMSU 80 orbitmotor
- Planetaire reductor met negatieve schijvenrem in oliebad.
- De trommel is gegleufd en voorzien van een kabelandrukrol voor een altijd correcte opwikkeling van de kabel.
- Aanwezigheid van een kabelgeleider voor een nog betere opwikkeling van de kabel op de trommel.
- Classificatie ISO 4301/1: T4,L2,M4.

Beschermingen:

- Positieve hydraulische eindaanslag daling.
- Positieve hydraulische eindaanslag stijging.





[kg] (lb)	[t] (t)	[mm] (in) x [m] (ft)	[m/min] (ft/min)	[bar] (psi)	[mm] (in)												[kg] (lb)
				P max													
5000 (11023)	5 (5)	∅ 12 (0,5) x 53 (174)	21,5 (70)	275 (3988)	A	B	C	D	E	F	G	H	I	L	M	N	510 (1124)
					1810 (71)	900 (35)	557 (22)	814 (32)	353 (14)	320 (12)	838 (33)	126 (5)	750 (29)	15 (0,6)	680 (27)	200 (8)	

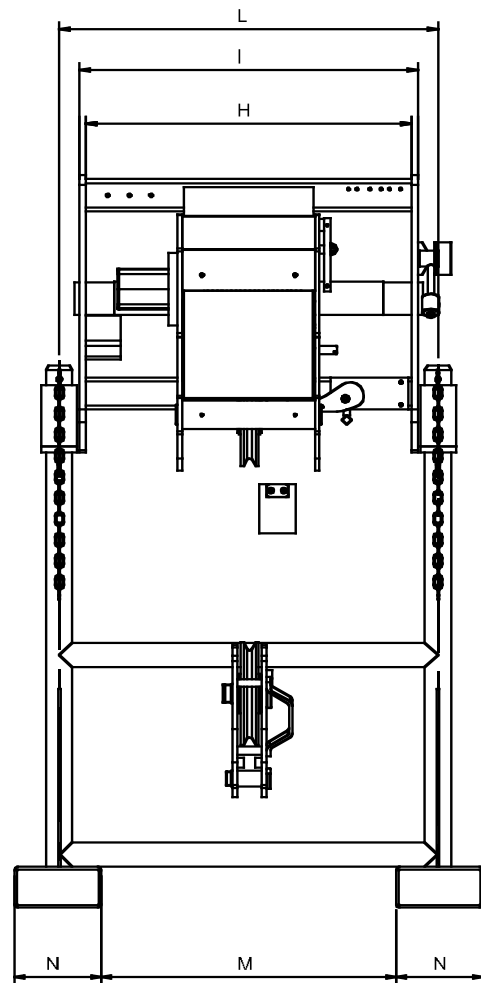
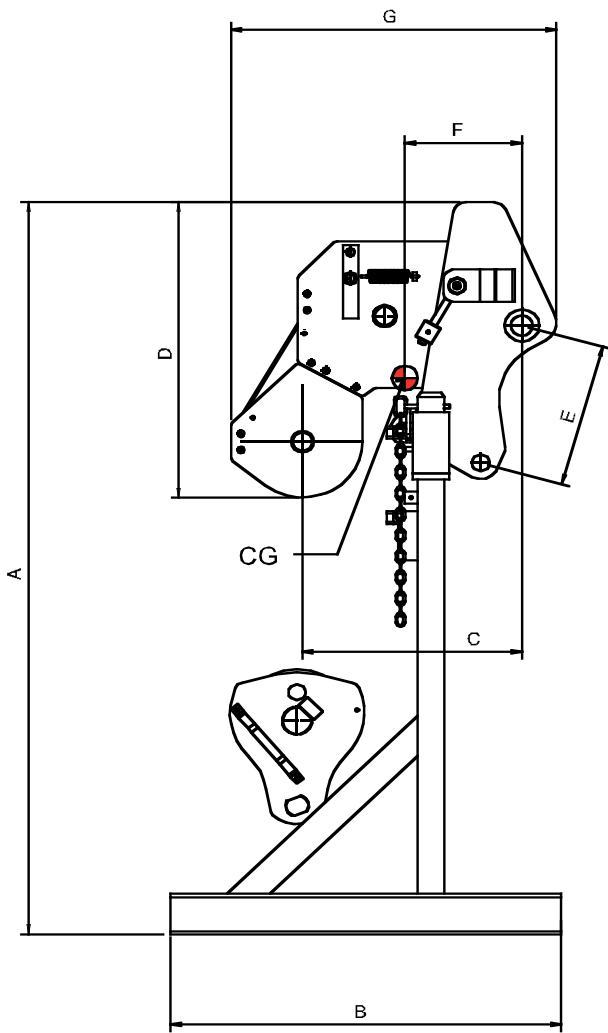

IT

MESSA IN SERVIZIO E UTILIZZO

Per la vostra sicurezza, prima di iniziare un ciclo di lavoro, attenersi alle Istruzioni obbligatorie di verifica e controllo:

- verificare l'integrità della struttura esterna dell'argano.
- verificare il corretto collegamento idraulico degli innesti rapidi 1, 2, Drenaggio e lo stato dei tubi flessibili (Fig.1);
- controllare il corretto funzionamento del fine corsa discesa fune H (Fig.2);
- controllare il corretto funzionamento del fine corsa salita fune L (Fig.2);
- controllare lo stato della fune e il corretto avvolgimento sul tamburo A (Fig.3);
- controllare il corretto movimento laterale e di rotazione della puleggia di guida fune B (Fig.3);
- controllare lo stato dei capocorda C (Fig.4) e E (Fig.5);

US

STARTING UP AND USE

For your safety, before starting a work cycle, follow the Compulsory instructions for inspection and control:

- check to make sure the external structure of the winch is intact.
- Check to ensure the correct hydraulic connection of quick-release couplings 1, 2, drainage and the condition of the hose pipes (Fig.1);
- check to ensure correct working of the rope descent limit switch H (Fig.2);
- check to ensure correct working of the rope ascent limit switch L (Fig.2);
- check the condition of the rope and that it is wound correctly on the drum A (Fig.3);
- check the correct lateral movement and rotation of the rope guide pulley B (Fig.3);
- check the condition of cable terminals C (Fig.4) and E (Fig.5);

NL

INBEDRIJFSTELLING EN GEBRUIK

Houd u, voor uw eigen veiligheid, voor met een werkcyclus aan te vangen, aan de **verplichte controle-instructies**:

- controleer of de buitenste structuur van de lier intact is.
- controleer of de hydraulische verbinding van de snelkoppelingen 1, 2, Afvoer en de staat van de slangen in orde zijn (Fig.1);
- controleer de werking van de eindslag kabel omlaag H (Fig.2);
- controleer de werking van de eindslag kabel omhoog L (Fig.2);
- controleer de staat van de kabel en de opwikkeling op de trommel A (Fig.3);
- controleer de zijdelingse beweging en draai beweging van het kabelgeleidewiel B (Fig.3);
- controleer de staat van het kabeluiteinde C (Fig.4) en E (Fig.5);

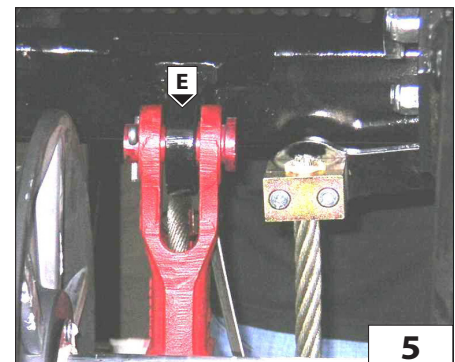
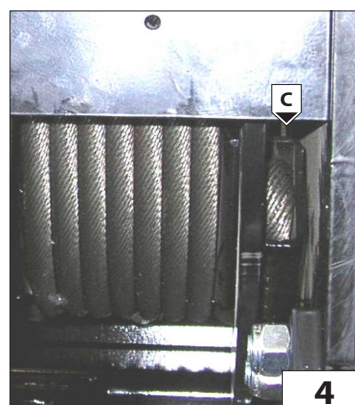
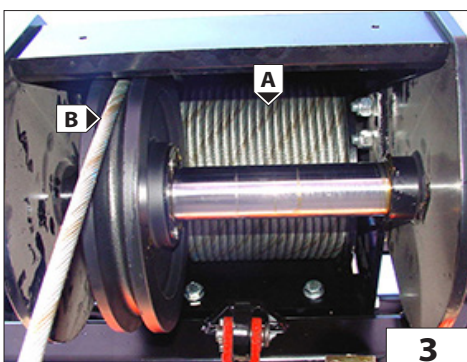
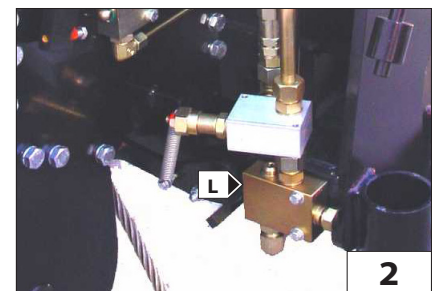
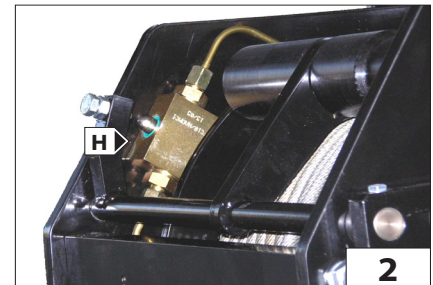
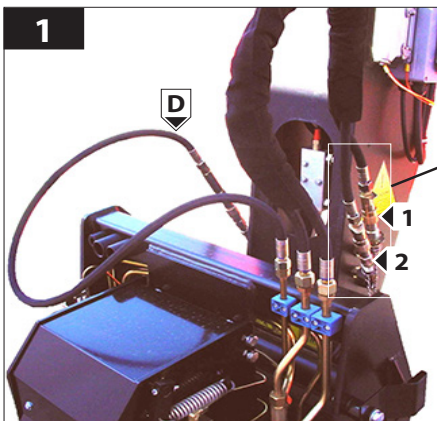

IT

- verificare l'integrità del bozzello e la rotazione della sua puleggia F (Fig.6);
- verificare lo stato del gancio: che non sia deformato, che ruoti liberamente e che la linguetta di sicurezza sia efficiente G (Fig.6);
- controllare l'aggancio dell'argano alla macchina operatrice J (Fig.7).

Per l'utilizzo, dalla posizione di parcheggio, sganciare l'argano dal suo piedistallo, sfilando i fermi di sicurezza. K (Fig.7)

US

- check the condition of the pulley block and rotation of the pulley F (Fig.6);
- check the condition of the hook: to make sure it is not deformed, that it rotates freely and that the safety tab G (Fig. 6) is in working order;
- check the hook-up of the winch to the operating machine J (Fig. 7).

To use, from the parking position, unhook the winch from its frame, removing the safety catches. K (Fig.7)

NL

- controleer de takel en de draaiing van zijn kabelschijf F (Fig.6);
- controleer de staat van de haak: of deze niet vervormd is, of hij vrij draait en of zijn veiligheidssluiting efficiënt is G (Fig.6);
- controleer de aankoppeling van de lier aan de machine J (Fig.7).

Voor het gebruik de lier, vanuit zijn parkeerstand, van zijn staander haken door de beveiligingen eruit te trekken. K (Fig.7)





IT

MANUTENZIONE

- RIDUTTORE
- FUNE, PULEGGIA E CAPOCORDA
- BOZZELLO
- GANCIO
- FINE CORSA DISCESA FUNE
- FINE CORSA SALITA FUNE
- IMPIANTO IDRAULICO

US

MAINTENANCE

- REDUCTION GEAR
- ROPE, PULLEY AND CABLE TERMINAL
- PULLEY BLOCK
- HOOK
- ROPE DESCENT LIMIT SWITCH
- ROPE ASCENT LIMIT SWITCH
- HYDRAULIC SYSTEM

NL

ONDERHOUD

- REDUCTOR
- KABEL, KABELSCHIJF en KABELUI-
TEINDEN
- TAKEL
- HAAK
- EINDAANSLAG KABEL OMLAAG
- EINDAANSLAG KABEL OMHOOG
- HYDRAULISCH CIRCUIT

IT

RIDUTTORE

Una corretta lubrificazione consente un buon funzionamento e una lunga durata del riduttore.

Per accedere all'indicatore di livello o al tappo di rabbocco olio, occorre srotolare completamente la fune dal tamburo.

Controllare il livello dell'olio ogni 100 ore A (Fig.8b) e all'occorrenza rabboccare A (Fig.8b) con olio dello stesso tipo di quello presente all'interno del riduttore (SHELL SPIRAX HD80 W90).

Si consiglia l'utilizzo di olio per ingranaggi con additivazione EP con viscosità SAE 80W/90 oppure SAE 85W/140.

La prima sostituzione dell'olio deve essere effettuata dopo 150 ore di funzionamento, successivamente ogni 1000 ore di funzionamento.

Eseguire il cambio dell'olio con riduttore ancora caldo per facilitare un completo svuotamento.

Per scaricare l'olio, ruotare il tamburo del motore portando il tappo di rabbocco / scarico A (Fig.8a) verso il basso. Svitare il tappo A (Fig.8a) e scaricare completamente l'olio.

Ruotare il tamburo portando il foro di rabbocco/scarico sull'asse orizzontale A (Fig.8b).

Rabboccare con olio nuovo e di tipo corretto fino a quando l'olio non fuoriesce da foro di livello A (Fig.8b) (1,3 lt).

Riavvitare i tappi e riavvolgere la fune.

US

REDUCTION GEAR

Correct lubrication allows proper working and longer life of the reduction gear.

To access the level indicator or oil topping up cap, the rope must be unwound completely from the drum.

Check the oil level at least every 100 hours A (Fig.8b) and if required, top up A (Fig.8b) with oil of the same type as that present inside the reduction gear (SHELL SPIRAX HD80 W90).

Use gear oil with additive EP with viscosity SAE 80W/90 or SAE 85W/140.

The first oil change must be after 150 hours of operation, then subsequently every 1000 hours of operation.

Change the oil with the reduction gear still hot to allow complete drainage.

To drain the oil, turn the engine drum so that the filler/drainage cap A (Fig.8a) is facing downwards.

Unscrew cap A (Fig.8a) and drain out the oil completely.

Turn the drum to bring the topping up/drainage hole horizontal A (Fig.8b).

Top up with fresh oil of the correct type until the oil flows out through the level hole A (Fig.8b) (1.3 l).

Screw the cap back on and rewind the rope.

NL

REDUCTOR

Een correcte smering maakt een goede werking en een lange levensduur van de reductor mogelijk.

Om toegang te verkrijgen tot de oliepeilindicator of de oliebijvuldop, moet de kabel helemaal van de trommel gerold worden.

Controleer het oliepeil om de 100 uren A (Fig.8b) en indien nodig bijvullen A (Fig.8b) met olie van hetzelfde soort als dat aanwezig is in de reductor (SHELL SPIRAX HD80 W90).

Er wordt aangeraden olie voor tandwielen te gebruiken met additievering van EP met viscositeit SAE 80W/90 of SAE 85W/140.

De eerste olieversing moet na 150 werkuren plaatsvinden, daarna om de 1000 werkuren.

Ververs de olie met nog warme reductor om een complete leging te vergemakkelijken.

Om de olie af te voeren, de trommel van de motor zodanig draaien dat de bijvul/aftapdop A (Fig.8a) naar beneden staat.

Draai de dop A (Fig.8a) los en laat alle olie weglopen.

Draai de trommel zodanig dat de bijvul/aftapopening op de horizontale as staat A (Fig.8b).

Bijvullen met nieuwe olie van het juiste type totdat de olie door de oliepeilopening naar buiten komt A (Fig.8b) (1,3 l) Draai de doppen weer vast en wikkel de kabel weer op.

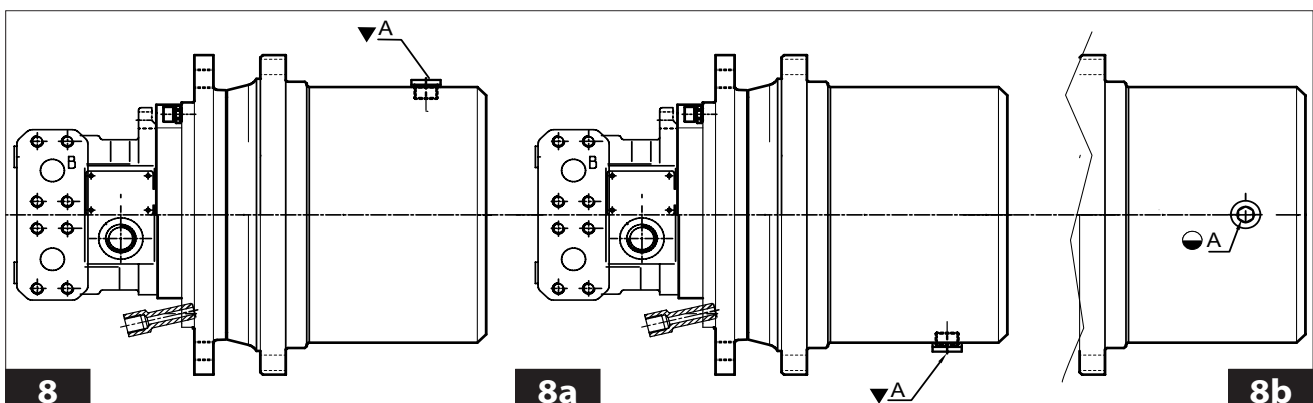
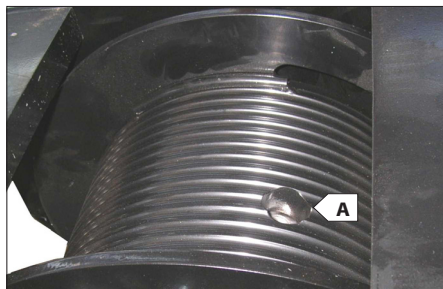

IT

FUNE, PULEGGIA e CAPOCORDA

Controllare giornalmente che la fune A (Fig.9) sia sempre in ottimo stato, che non ci siano filamenti rotti (Fig.9a) e che sia ben arrotolata sul tamburo B (Fig.9).

Altrimenti sostituirla con una nuova e dello stesso diametro e caratteristiche. Controllare la lubrificazione della fune, se necessita lubrificare con grasso industriale oppure olio sintetico anti-polvere.

Controllare giornalmente e mantenere lubrificato il perno C (Fig.9) su cui ruota la puleggia di guida D (Fig.9), che dovrà avere sempre un buono movimento di rotazione e di traslazione laterale. Se necessita, lubrificare con grasso al sapone di litio il perno.

Assicurarsi dell'integrità dei capocorda E (Fig.10) e dei suoi morsetti fermafune F (Fig.10).

US

ROPE, PULLEY AND CABLE TERMINAL

Check daily to make sure the rope A (Fig.9) is always in excellent condition, that it is not frayed (Fig.9a) and that it is wound perfectly around the drum B (Fig.9).

If necessary replace with a new rope having the same diameter and features. Check the lubrication of the rope, if necessary, lubricate with industrial grease or dust-proof synthetic oil.

Check the pin C (Fig. 9) on which the guide pulley D (Fig.9) rotates daily and keep it lubricated, it must always rotate and move transversely freely. If necessary, lubricate the pin with lithium soap grease.

Ensure the integrity of the cable terminals E (Fig.10) and the rope retainer clamps F (Fig.10).

NL

KABEL, KABELSCHIJF en KABELUITEINDEN

Controleer dagelijks of de kabel A (Fig.9) in optimale staat verkeert, of er geen draden stuk zijn (Fig.9a) en of hij goed op de trommel gewonden is B (Fig.9).

Vervang hem anders door een nieuwe met dezelfde diameter en eigenschappen.

Controleer de smering van de kabel, indien nodig smeren met industrieel vet of synthetische olie tegen stof.

Controleer dagelijks de pen C (Fig.9) waarop de geleideschijven D (Fig.9) draait en houd ze gesmeerd. Deze moet altijd een goede draai beweging en zijwaartse schuif beweging behouden. Indien nodig, de pen invetten met lithiumzeepvet.

Controleer de staat van de kabeluiteinden E (Fig.10) en de kabelklemmen F (Fig.10).

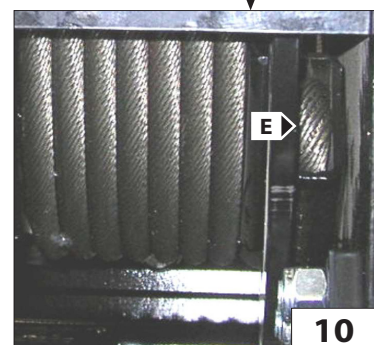
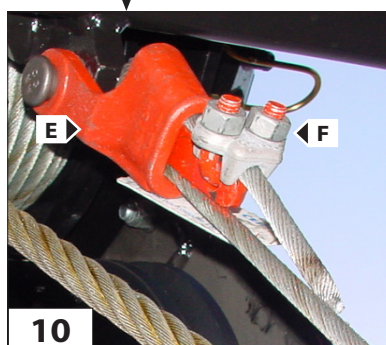
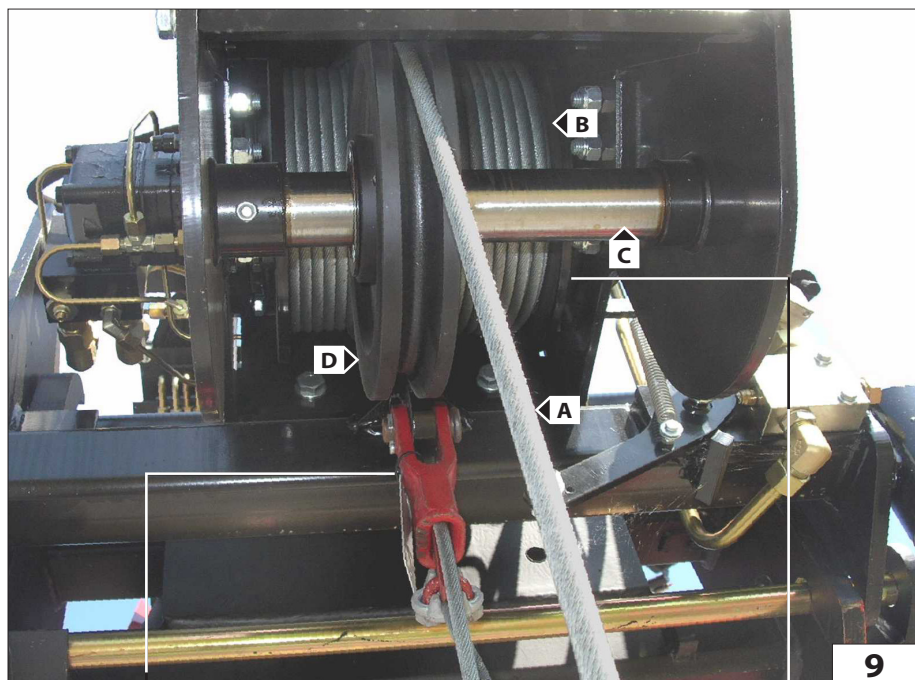
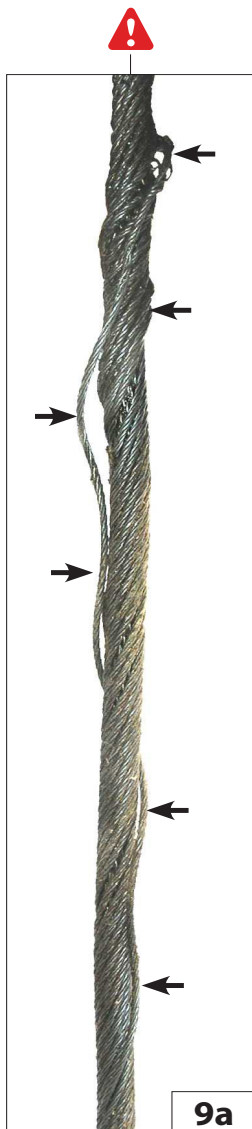

IT

BOZZELLO

Per una massima efficienza e sicurezza, mantenere intatta la struttura esterna H (Fig.11) e controllare che la puleggia L (Fig.12) ruoti correttamente sul suo perno M (Fig.12) .

Se necessità, lubrificare con grasso al sapone di litio il perno M (Fig.11).

GANCIO

Per una massima efficienza mantenere lubrificata la vite di rotazione del gancio N (Fig.12).

Senza carico sospeso, il gancio deve sempre ruotare liberamente e con la sola pressione della mano P (Fig.12). Controllare lo stato e l'efficienza della linguetta di sicurezza O (Fig.12).

US

PULLEY BLOCK

For maximum efficiency and safety, keep the external structure H (Fig.11) intact and check to make sure the pulley L (Fig.12) rotates correctly on its pin M (Fig.12) .

If necessary, lubricate the pin M (Fig. 11) with lithium soap grease

HOOK

For maximum efficiency keep the hook rotation screw N (Fig. 12) lubricated.

Without a load hanging from it, the hook must always rotate freely when pushed slightly by hand P (Fig. 12).. Check the condition and efficiency of safety tab O (Fig. 12).

NL

TAKEL

Voor een maximale efficiëntie en veiligheid, de buitenste structuur intact houden H (Fig.11) en controleren of de kabelschijf L (Fig.12) goed op zijn pen draait M (Fig.12).

Indien nodig, de pen M (Fig.11) invetten met lithiumzeepvet.

HAAK

Voor een maximale efficiëntie de draaischroef van de haak N (Fig.12) gesmeerd houden.

Zonder hangende lading moet de haak altijd vrij kunnen draaien door er met de hand tegenaan te drukken P (Fig.12).

Controleer de staat en de efficiëntie van de veiligheidssluiting O (Fig.12).

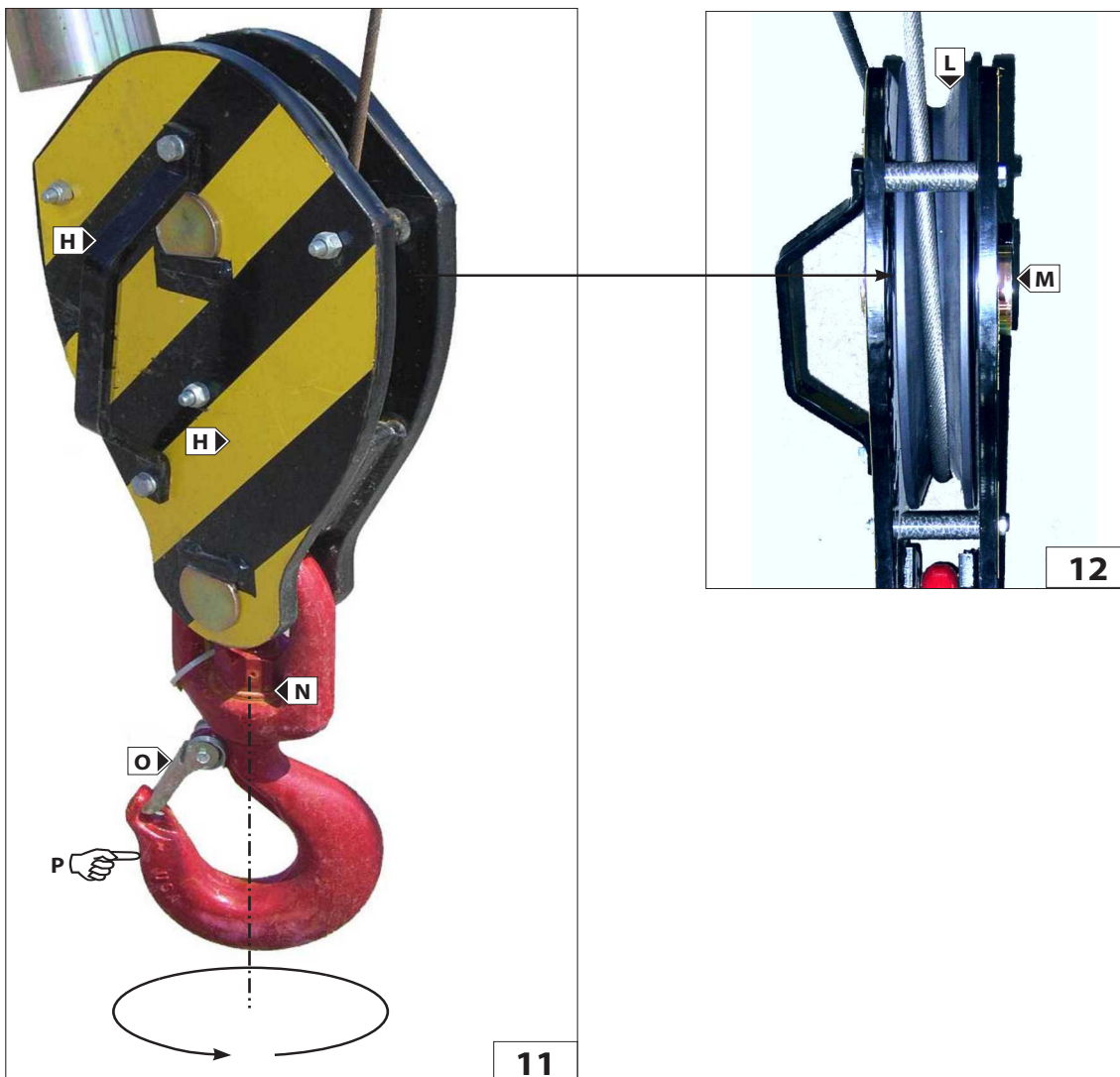

IT

FINE CORSA DISCESA FUNE (Fig.13)

Giornalmente per una massima efficienza mantenere sempre pulito il pistoncino e la valvola idraulica di sicurezza; controllare il serraggio dei raccordi e lo stato dei tubi . Inoltre verificare l'integrità del leveraggio di contatto finecorsa discesa e la tenuta della sua molla.

FINE CORSA SALITA FUNE

Giornalmente per una massima efficienza mantenere sempre pulito il pistoncino e la valvola idraulica di sicurezza; controllare il serraggio dei raccordi e lo stato dei tubi . Inoltre verificare l'integrità del leveraggio di contatto finecorsa salita e la tenuta della sua molla. (Fig.14)

IMPIANTO IDRAULICO (Fig.15)

Ispezionare giornalmente raccordi, valvole, tubi, per evitare eventuali perdite di olio che compromettano il rendimento e la durata dell'organo.

US

ROPE DESCENT LIMIT SWITCH (Fig. 13)

For maximum efficiency, check daily and keep the piston and hydraulic safety valve clean, check to make sure the connections are tightened properly and check the condition of the pipes. Also check the condition of the descent limit switch contact linkages and hold of its spring.

ROPE ASCENT LIMIT SWITCH

For maximum efficiency, check daily and keep the piston and hydraulic safety valve clean, check to make sure the connections are tightened properly and check the condition of the pipes. Also check the condition of the ascent limit switch contact linkages and hold of its spring. (Fig.14)

HYDRAULIC SYSTEM (Fig.15)

Check the connectors, valves, tubes daily to prevent oil leaks which could affect the performance and life of the winch.

NL

EINDAANSLAG KABEL OMLAAG (Fig.13)

Voor een maximale efficiëntie dagelijks altijd het zuigertje en het hydraulische veiligheidsventiel schoon houden; controleer of de verbindingen goed vast zitten en de staat van de leidingen. Controleer eveneens de staat van de hefbomen van de eindaanslag voor het dalen en zijn veer.

EINDAANSLAG KABEL OMHOOG

Voor een maximale efficiëntie dagelijks altijd het zuigertje en het hydraulische veiligheidsventiel schoon houden; controleer of de verbindingen goed vast zitten en de staat van de leidingen. Controleer eveneens de staat van de hefbomen van de eindaanslag voor het stijgen en zijn veer. (Fig.14)

HYDRAULISCHE INSTALLATIE (Fig.15)

Controleer dagelijks de verbindingstukken, kleppen en leidingen om eventuele olieklekken te voorkomen die het rendement en de levensduur van de lier zouden kunnen beïnvloeden.

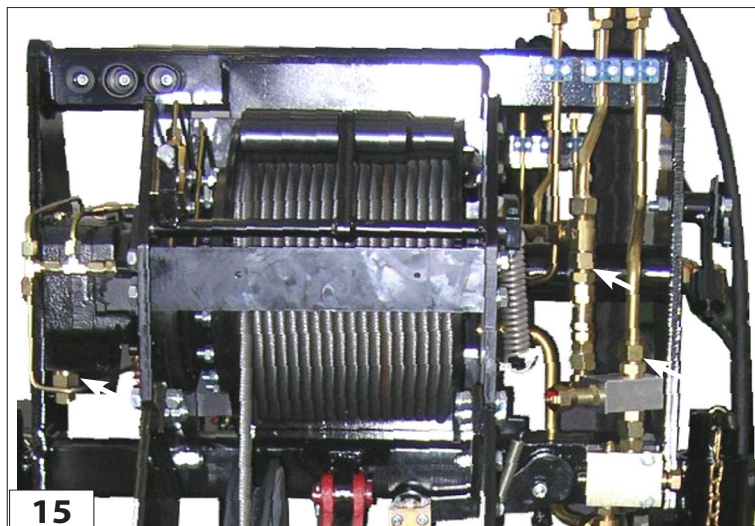

15

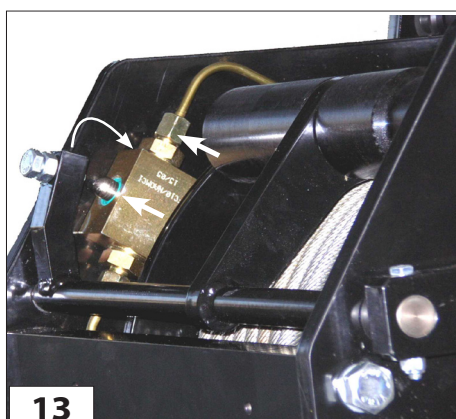

13

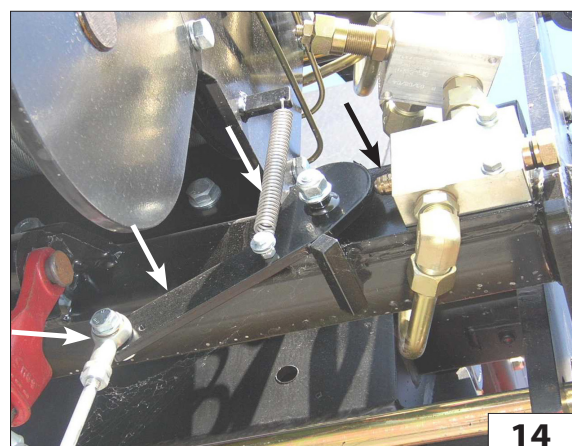

14

IT

US

NL

SCHEMA IDRAULICO

HYDRAULIC DIAGRAM

HYDRAULISCH SCHEMA

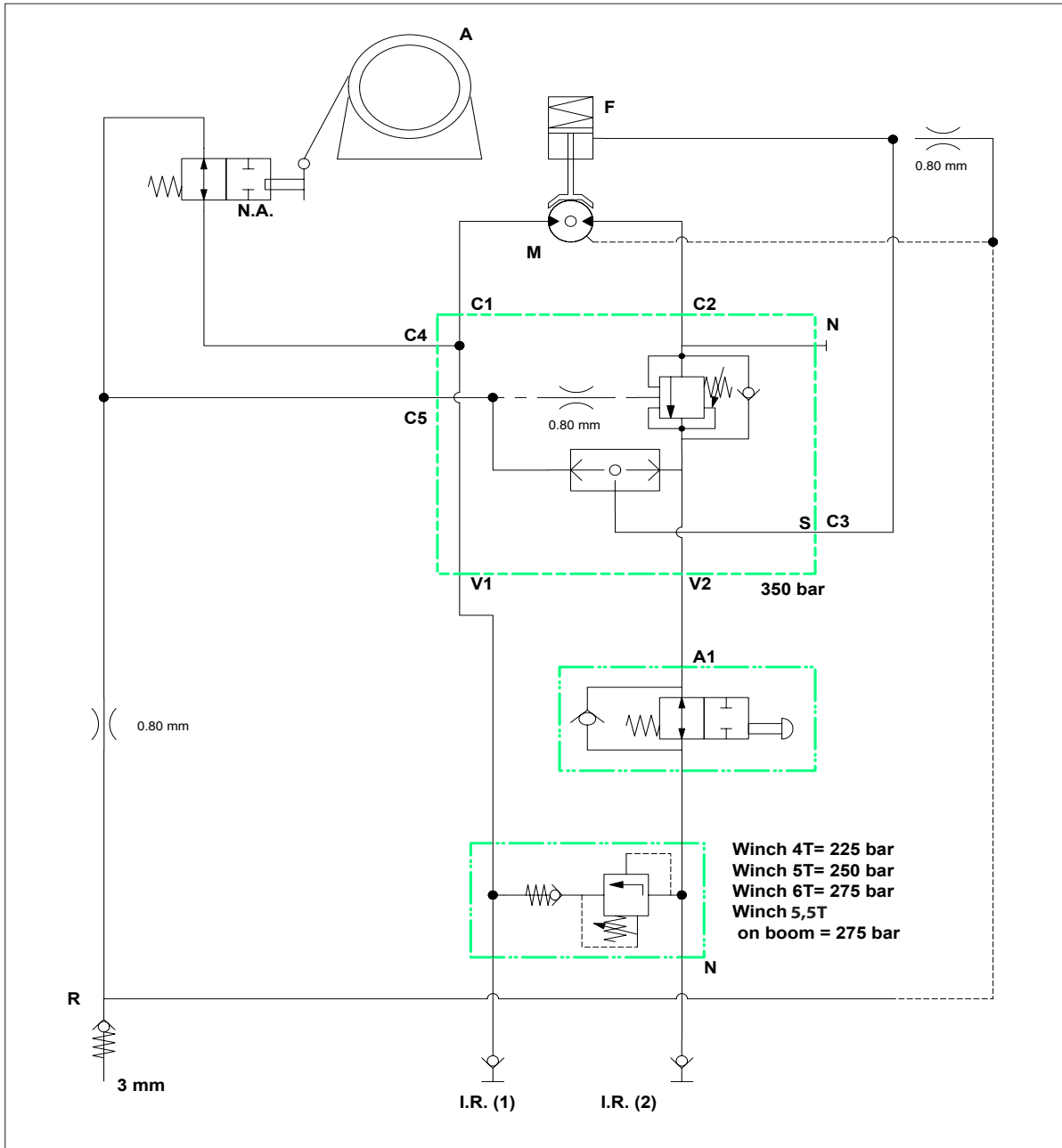

A = ARGANO
N.A. = MICRO MASSIMA DISCESA
R = SERBATOIO OLIO
I.R.1 = INNESTO RAPIDO
I.R.2 = INNESTO RAPIDO
A1 = MICRO MASSIMA SALITA
S = VALVOLA
N = VALVOLA MASSIMA PRESSIONE
M = MOTORE
F = FRENO

A = WINCH
N.A. = MAX. DESCENT MICRO SWITCH
R = OIL TANK
I.R.1 = QUICK-RELEASE COUPLING
I.R.2 = QUICK-RELEASE COUPLING
A1 = MAX. ASCENT MICRO SWITCH
S = VALVE
N = PRESSURE RELIEF VALVE
M = MOTOR
F = BRAKE

A = LIER
N.A. = MICRO MAXIMALE DALING
R = OLJETANK
I.R.1 = SNELKOPPELING
I.R.2 = SNELKOPPELING
A1 = MICRO MAXIMALE STIJLING
S = VENTIEL
N = MAXIMUMDRUKVENTIEL
M = MOTOR
F = REM



Questa pagina è intenzionalmente vuota
This page is left blank intentionally
Deze pagina is opzettelijk leeg gelaten



WINCH 5,5T

IT

ARGANO 5,5 T

Descrizione:

Argano idraulico 5,5t.

Caratteristiche:

- Tiro al 3° strato di 5500Kg.
- Velocità massima al 3° strato 21m/min.
- Il tiro è in due taglie.
- La fune è di 65 m (MRT2150) - 72 m (MRT2550), diametro 12 mm disposta su tre strati.
- Motore orbitale Sauer-Danfoss OMSU 80
- Riduttore epicicloidale con freno negativo a dischi in bagno d'olio.
- Il tamburo è filettato e dotato di un rullo pressa fune in modo da assicurare sempre un corretto avvolgimento della fune.
- Presenza di un guida fune che migliora ulteriormente l'avvolgimento della fune sul tamburo.
- Classificazione ISO 4301/1: T4,L2,M4.

Sicurezze:

- Fine corsa discesa idraulico positivo.
- Fine corsa salita idraulico positivo.

US

WINCH 5,5 T

Description:

5,5t Hydraulic winch

Features:

- Pull at 3rd layer 5500 kg.
- Maximum speed at 3° layer 21 m/min.
- The pull is in two sheaves.
- The rope is 65 m (MRT 2150) - 72 m (MRT 2550) long, 12 mm diameter arranged in three layers.
- Sauer-Danfoss OMSU 80 orbital motor
- Planetary drive with negative oil bath disk brake
- The drum is threaded and provided with a rope press roller in order to always ensure correct winding of the rope.
- Presence of a rope guide which further improves the winding of the rope on the drum.
- ISO 4301/1 Classification: T4, L2, M4.

Safety devices:

- Positive hydraulic descent limit switch.
- Positive hydraulic ascent limit switch.

NL

WINCH 5,5 T

Beschrijving:

Hydraulische lier 5,5t

Kenmerken:

- Trekkracht 3de laag 5500 kg.
- Maximumsnelheid 3de laag 21 m/min.
- Kabel dubbel gebruikt.
- De kabel is 65 m (MRT2150) - 72 m (MRT2550), diameter 12 mm in drie lagen.
- Sauer-Danfoss OMSU 80 orbitmotor
- Planetaire reductor met negatieve schijvenrem in oliebad.
- De trommel is gegleufd en voorzien van een kabelandrukrol voor een altijd correcte opwikkeling van de kabel.
- Aanwezigheid van een kabelgeleider voor een nog betere opwikkeling van de kabel op de trommel.
- Classificatie ISO 4301/1: T4,L2,M4.

Beschermingen:

- Positieve hydraulische eindaanslag daling.
- Positieve hydraulische eindaanslag stijging.





[kg] (lb)	[t] (t)	[mm] (in) x [m] (ft)		[m/min] (ft/min)	[bar] (psi)	[mm] (in)											[kg] (lb)	
					P max													
5500 (12125)	8 (8)	MRT 2150+	MRT 2550+	21 (69)	275 (3988)	A	B	C	D	E	F	G	H	I	L	M	N	510 (1124)
		Ø 12 (0,5) x 65 (213)	Ø 12 (0,5) x 72 (236)			1810 (71)	900 (35)	557 (22)	814 (32)	353 (14)	320 (12)	838 (33)	126 (5)	750 (29)	15 (0,6)	680 (27)	200 (8)	

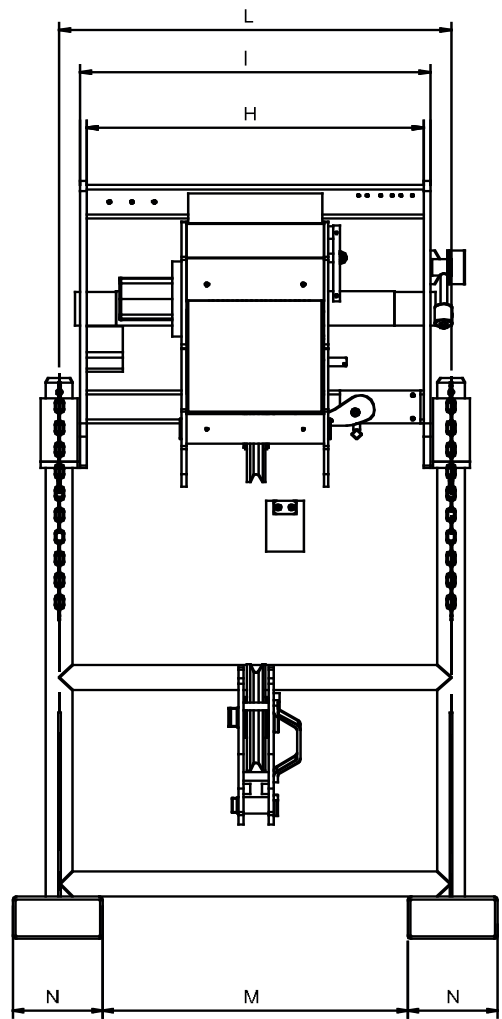
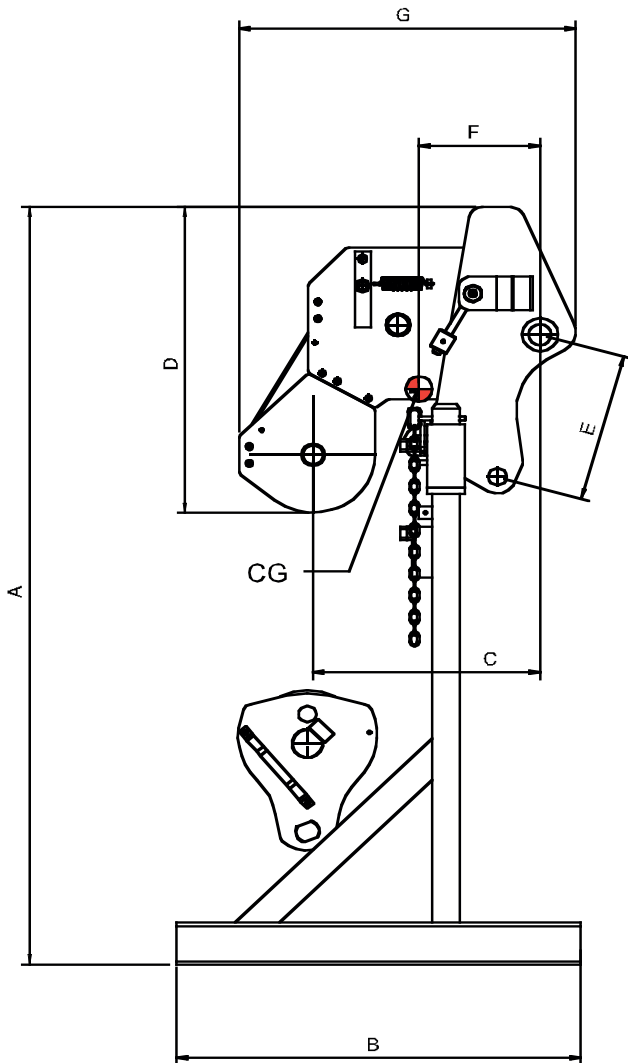

IT

US

NL

UTILIZZO DELL'ARGANO SUL BRACCIO

USING THE WINCH ON THE BOOM

GEBRUIK VAN DE LIER OP DE ARM

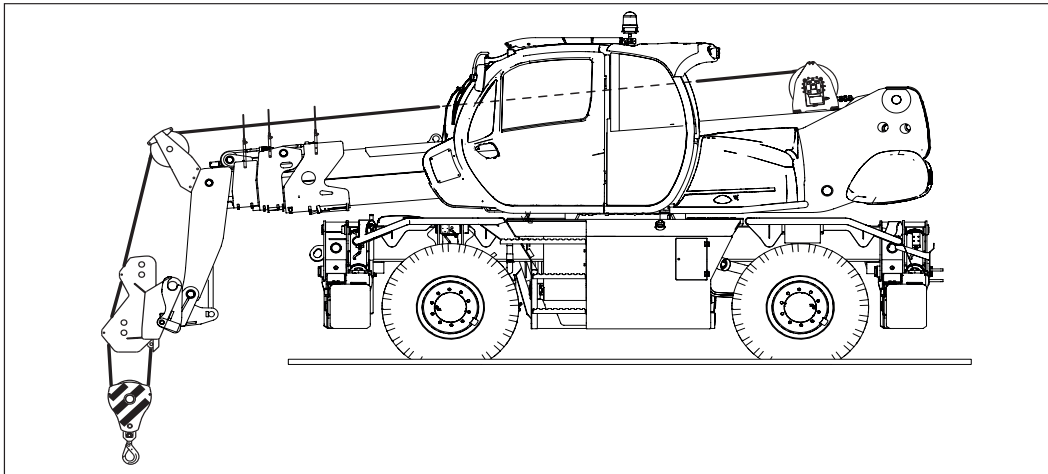

ATTIVAZIONE ARGANO

- Collegare i raccordi idraulici all'argano (Fig. 1 - Rif. A).
- Togliere la coppiglia (Fig. 2 - Rif. B) e sfilare il perno dalla staffa di riposo sul braccio esterno (Fig. 2 - Rif. C).
- Comandare la discesa della fune per permettere il passaggio attraverso i tre guida fune (Fig. 3 - Rif. D).
- Inserire la fune nella puleggia togliendo il perno (Fig. 4 - Rif. E).
- Liberare la fune dal ferma cavo (Fig. 5 - Rif. F) togliendo il morsetto di sicurezza.
- Inserire la fune nelle pulegge guida fune (Fig. 6 - Rif. G).

ACTIVATING THE WINCH

- Connect the hydraulic fittings to the winch (Fig. 1 - Ref. A).
- Remove the cotter pin (Fig. 2 - Ref. B) and extract the pin from clevis on the outside boom (Fig. 2 - Ref. C).
- Lower the rope to let it pass through the three rope guides (Fig. 3 - Ref. D).
- Insert the rope in the pulley, removing the pin (Fig. 4 - Ref. E).
- Free the rope from the cable clamp (Fig. 5 - Ref. F) after removing the safety clamp.
- Insert the rope in the rope guide pulley (Fig. 6 - Ref. G).

ACTIVERING LIER

- Sluit de hydraulische leidingen aan op de lier (Fig.1 - Ref.A).
- Verwijder de pin (Fig.2 - Ref.B) en schuif de pen uit de staaf op de externe arm (Fig.2 - Ref.C).
- Laat de kabel dalen en zorg ervoor dat hij door de drie kabelgeleiders gaat (Fig.3 - Ref.D).
- Steek de kabel in de schijf en verwijder de pin (Fig.4 - Ref.E).
- Bevrijd de kabel uit de kabelblokkering (Fig.5 - Ref.F) door de veiligheidsklem te verwijderen.
- Steek de kabel in de kabelgeleideschijf (Fig.6 - Ref.G).

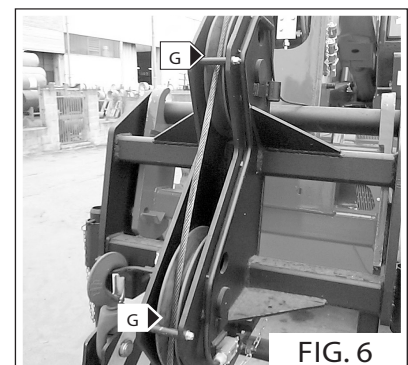
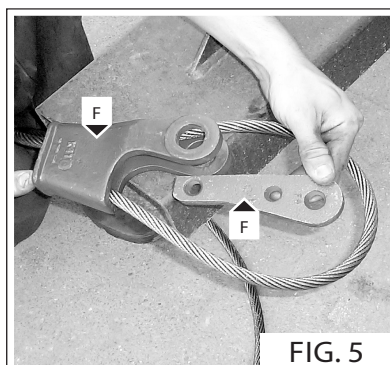
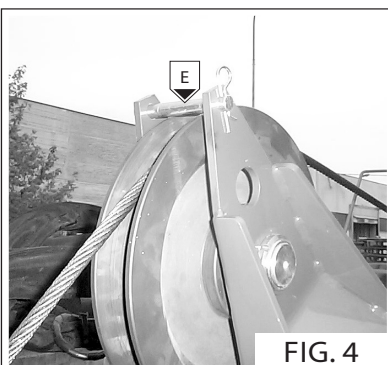
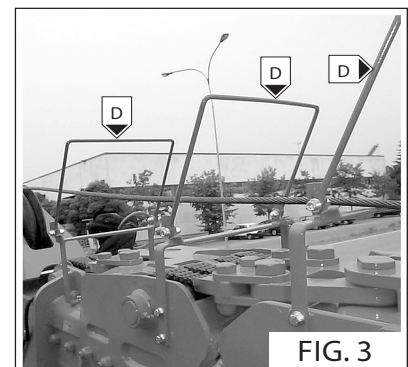
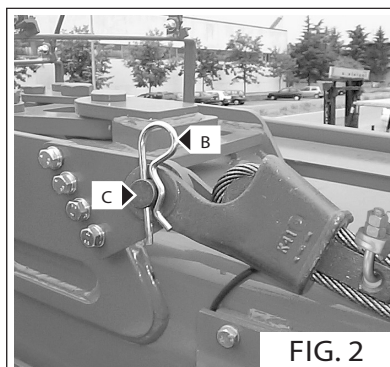
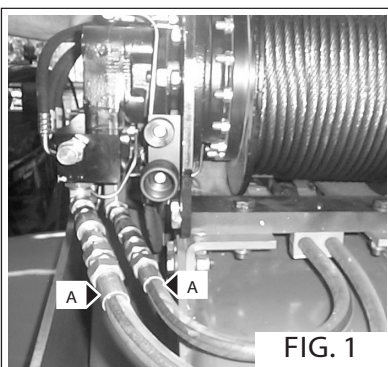

IT

- Inserire la fune nel bozzello (Fig. 7/8 - Rif. A) (la fune deve passare fra la puleggia ed i due perni (Fig. 7/8 - Rif. B).
- Inserire la fune nel peso di fine corsa salita fune (Fig. 9 - Rif. C).
- Inserire la fune nel ferma cavo (Fig. 10 - Rif. D) e bloccarla correttamente dando alcuni colpi di martello in entrambi i lati dell'insieme (Fig. 11 - Rif. E).
- Avvitare il morsetto di sicurezza fune al ferma cavo (Fig. 12 - Rif. F).
- Montare il ferma cavo nell'apposito alloggiamento sotto le pulegge guida fune (Fig. 12 - Rif. G).

US

- Insert the rope in the block (Fig. 7/8 - Ref. A) (the rope must pass through the pulley and the two pins (Fig. 7/8 - Rif. B).
- Insert the rope in the rope lift stop weight (Fig. 9 - Ref. C).
- Insert the rope in the cable clamp (Fig. 10 - Ref. D) and block it properly by tapping with a hammer on both sides of the assembly (Fig. 11 - Ref. E).
- Screw the safety clamp back on the cable clamp (Fig. 12 - Ref. F).
- Fit the cable clamp in its housing under the rope guide pulley (Fig. 12 - Ref. G).

NL

- Steek de kabel in de takel (Fig.7/8 - Ref.A) (de kabel moet tussen de schijf en de twee pinnen schuiven (Fig.7/8 - Ref.B).
- Steek de kabel in het gewicht van de eindaanslag kabel omhoog (Fig.9 - Ref.C).
- Steek de kabel in de kabelblokkering (Fig.10 - Ref.D) en blokkeer hem op correcte wijze door een paar keer met een hamer op beide kanten van het geheel te kloppen (Fig.11 - Ref.E).
- Draai de veiligheidsklem van de kabel vast op de kabelblokkering (Fig.12 - Ref.F).
- Monteer de kabelblokkering in de desbetreffende houder onder de kabelgeleideschijven (Fig.12 - Ref.G).

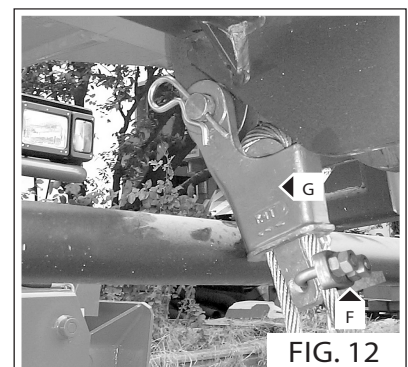
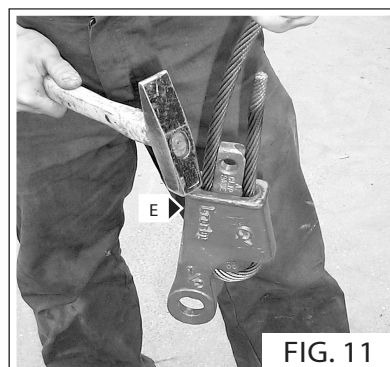
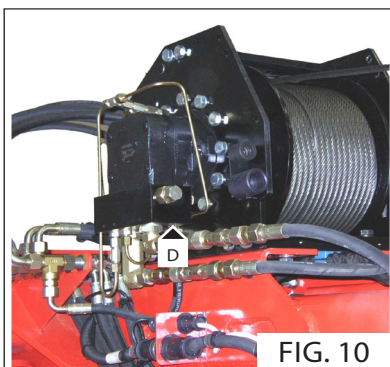
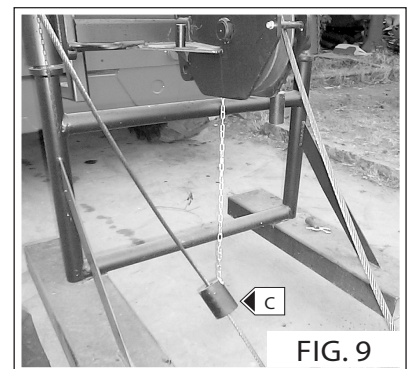
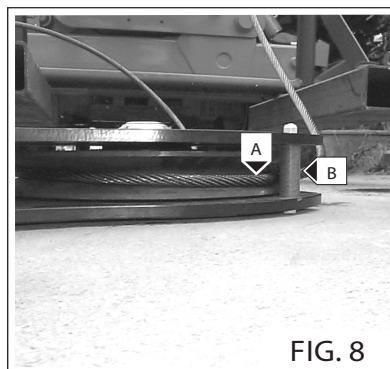
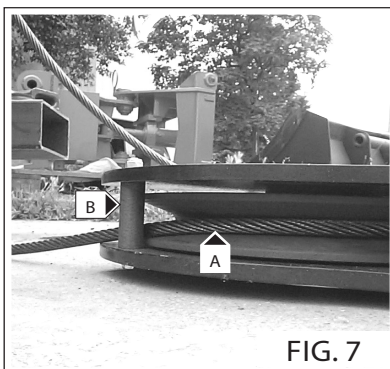

IT

- Posizionare la presa a riposo (Fig. 13 - Rif. A) e inserire il cavo per il fine corsa salita fune (Fig. 13 - Rif. B).
- Da questo momento si attivano i seguenti blocchi di movimento dovuti al fine corsa salita fune :
 - blocco salita fune
 - blocco sfilo braccio
 - blocco salita/discesa braccio



Attenzione :

- Se non viene attivato il fine corsa salita fune é in grave pericolo :
- l'incolumità delle persone circostanti
 - l'incolumità delle cose circostanti
 - l'integrità strutturale della macchina
 - il materiale sollevato
- Selezionare sul sistema di sicurezza la corretta posizione di lavoro per l'argano sul braccio della macchina e togliere il supporto delle pulegge guida fune (Fig. 14 - Rif. C).

US

- Position the gripper on hold (Fig. 13 - Ref. A) and insert the cable for the rope lift stop (Fig. 13 - Ref. B).
- From this moment onwards, the following movement blocks are activated due to the rope lift limitswitch :
 - rope lift block
 - boom extension block
 - boom ascent/descent block



Attention :

- If the rope lift stop is not activated there is serious risk for the safety of:
- bystanders
 - objects in the surrounding area
 - the machine structure
 - the material lifted
- Select on the safety system the correct operating position for the winch on the machine boom and remove the rope guide pulley support (Fig. 14 - Ref. C).

NL

- Zet de stekker in de ruststand (Fig.13 - Ref.A) en plaats de kabel voor de eindaanslag kabel omhoog (Fig.13 - Ref.B).
- Vanaf dit moment worden de volgende blokken geactiveerd door de eindaanslag kabel omhoog:
 - blok kabel omhoog
 - blok uitschuiven arm
 - blok stijgen/dalen arm



Let op:

- Als de eindaanslag kabel omhoog niet geactiveerd wordt, bestaat er groot gevaar voor:
- personen die zich in de nabije omgeving bevinden
 - voorwerpen die zich in de nabije omgeving bevinden
 - de structurele integriteit van de machine
 - het opgetilde materiaal
- Selecteer op het veiligheidssysteem de correcte werkpositie voor de lier op de arm van de machine en verwijder de steun van de kabelgeleideschijven (Fig.14 - Ref.C).

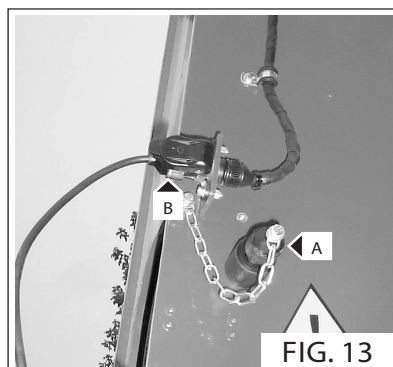

IT

INATTIVITA' DELL'ARGANO

- Per utilizzare altri accessori, ripetere le operazioni in ordine inverso ricordandosi di :
 - mettere il cavo per il fine corsa salita fune a riposo (Fig. 15 - Rif. A)
 - inserire la presa nella spina (Fig. 16 - Rif. B)
 - scollegare i raccordi idraulici dall'argano e riporli negli appositi supporti (Fig. 17 - Rif. C)
 - riporre il bozzello nell'apposito alloggiamento (Fig. 18 - Rif. D)
 - riporre il peso di fine corsa salita fune (Fig. 19 - Rif. E) nell'apposito perno (Fig. 19 - Rif. F)

US

PUTTING AWAY THE WINCH

- To use other accessories, repeat the operations described above in reverse order, and remember to :
 - put the rope lift limitswitch cable lying flat (Fig. 15 - Ref. A)
 - insert the plug into the socket (Fig. 16 - Ref. B)
 - disconnect the hydraulic fittings from the winch and replace them in their supports (Fig. 17 - Ref. C)
 - set the block back in its seating (Fig. 18 - Ref. D)
 - set the rope lift stop weight (Fig. 19 - Ref. E) back in its pin (Fig. 19 - Ref. F)

NL

ALS DE LIER NIET GEBRUIKT WORDT

- Om andere werktuigen te gebruiken, herhaal de handelingen in omgekeerde volgorde. Gelieve het volgende niet te vergeten:
 - breng de kabel voor de eindaanslag kabel omhoog in rustpositie (Fig.15 - Ref.A)
 - steek de stekker in het contact (Fig.16 - Ref.B)
 - koppel de hydraulische verbindingen van de lier los en plaats ze in de desbetreffende steunen (Fig.17 - Ref.C)
 - plaats de takel in de desbetreffende houder (Fig.18 - Ref.D)
 - plaats het gewicht van de eindaanslag kabel omhoog (Fig.19 - Ref.E) in de desbetreffende stift (Fig.19 - Ref.F)

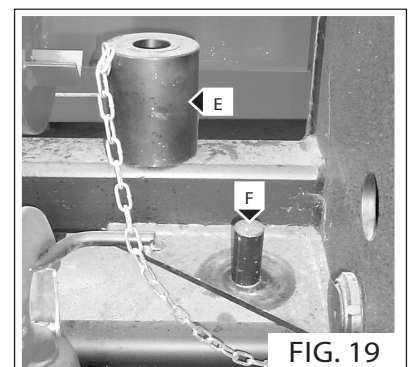
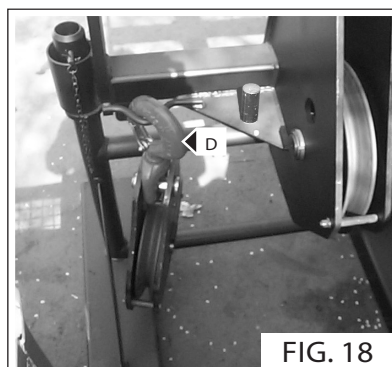
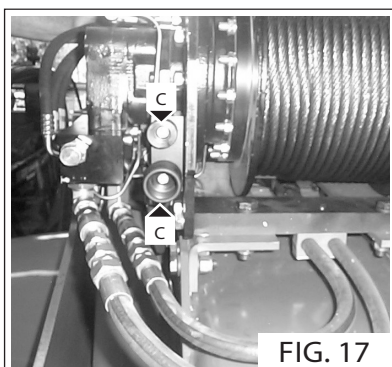
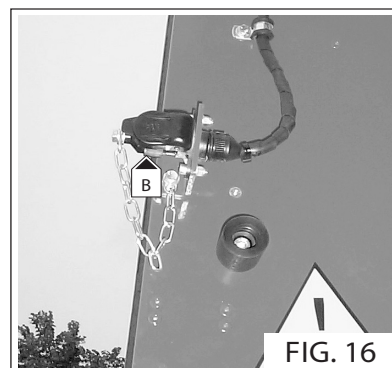



IT

MANUTENZIONE

- RIDUTTORE
- FUNE, PULEGGIA E CAPOCORDA
- BOZZELLO
- GANCIO
- FINE CORSA DISCESA FUNE
- FINE CORSA SALITA FUNE
- IMPIANTO IDRAULICO

US

MAINTENANCE

- REDUCTION GEAR
- ROPE, PULLEY AND CABLE TERMINAL
- PULLEY BLOCK
- HOOK
- ROPE DESCENT LIMIT SWITCH
- ROPE ASCENT LIMIT SWITCH
- HYDRAULIC SYSTEM

NL

ONDERHOUD

- REDUCTOR
- KABEL, KABELSCHIJF en KABELUI-
TEINDEN
- TAKEL
- HAAK
- EINDAANSLAG KABEL OMLAAG
- EINDAANSLAG KABEL OMHOOG
- HYDRAULISCH CIRCUIT

IT

RIDUTTORE

Una corretta lubrificazione consente un buon funzionamento e una lunga durata del riduttore.

Per accedere all'indicatore di livello o al tappo di rabbocco olio, occorre srotolare completamente la fune dal tamburo.

Controllare il livello dell'olio ogni 100 ore A (Fig.20b) e all'occorrenza rabboccare A (Fig.20b) con olio dello stesso tipo di quello presente all'interno del riduttore (SHELL SPIRAX HD80 W90). Si consiglia l'utilizzo di olio per ingranaggi con additivazione EP con viscosità SAE 80W/90 oppure SAE 85W/140.

La prima sostituzione dell'olio deve essere effettuata dopo 150 ore di funzionamento, successivamente ogni 1000 ore di funzionamento.

Eseguire il cambio dell'olio con riduttore ancora caldo per facilitare un completo svuotamento.

Per scaricare l'olio, ruotare il tamburo del motore portando il tappo di rabbocco / scarico A (Fig.20a) verso il basso.

Svitare il tappo A (Fig.20a) e scaricare completamente l'olio.

Ruotare il tamburo portando il foro di rabbocco/scarico sull'asse orizzontale A (Fig.20b).

Rabboccare con olio nuovo e di tipo corretto fino a quando l'olio non fuoriesce da foro di livello A (Fig.20b) (1,3 lt).

Riavvitare i tappi e riavvolgere la fune.

US

GEAR REDUCER

Correct lubrication will allow efficient working and long life of the gear reducer.

The rope must be unwound completely from the drum to access the level indicator or oil filler plug.

Check the oil level every 100 hours A (Fig.20b) and top up if necessary A (Fig.20b) with the same type of oil as that present in the gear reducer (SHELL SPIRAX HD80 W90).

Use of gear oil with EP additives with viscosity SAE 80W/90 or SAE 85W/140 is recommended.

Oil must be changed the first time after 150 hours of operation, and subsequently every 1000 hours of operation.

Change the oil with the gear reducer still hot so that the oil drains out completely.

To drain out the oil, turn the motor drum so that the filler/drain plug A (Fig.20a) is downwards.

Unscrew plug A (Fig.20a) and drain out the oil completely.

Turn the drum so that the filler/drain plug is on the horizontal axis A (Fig.20b).

Fill with the right type of oil until it starts flowing out through the levelhole A (Fig.20b). (1,3 lt)

Refit the plugs and rewind the rope.

NL

REDUCTOR

Een correcte smering maakt een goede werking en een lange levensduur van de reductor mogelijk.

Om toegang te verkrijgen tot de oliepeilindicator of de oliebijvuldop, moet de kabel helemaal van de trommel gerold worden.

Controleer het oliepeil om de 100 uren A (Fig.20b) en indien nodig bijvullen A (Fig.20b) met olie van hetzelfde soort als dat aanwezig is in de reductor (SHELL SPIRAX HD80 W90).

Er wordt aangeraden olie voor tandwielen te gebruiken met additievering van EP met viscositeit SAE 80W/90 of SAE 85W/140.

De eerste olieversing moet na 150 werkuren plaatsvinden, daarna om de 1000 werkuren.

Ververs de olie met nog warme reductor om een complete leging te vergemakkelijken.

Om de olie af te voeren, de trommel van de motor zodanig draaien dat de bijvul/aftapdop A (Fig.20a) naar beneden staat.

Draai de dop A (Fig.20a) los en laat alle olie weglopen.

Draai de trommel zodanig dat de bijvul-/aftapopening op de horizontale as staat A (Fig.20b).

Bijvullen met nieuwe olie van het juiste type totdat de olie door de oliepeilopening naar buiten komt A (Fig.20b) (1,3 l)

Draai de doppen weer vast en wikkel de kabel weer op.

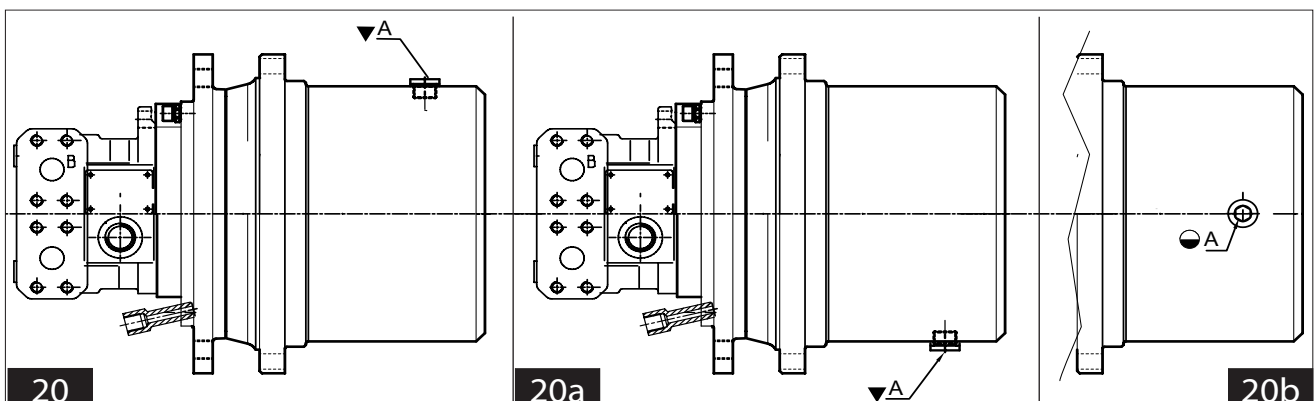
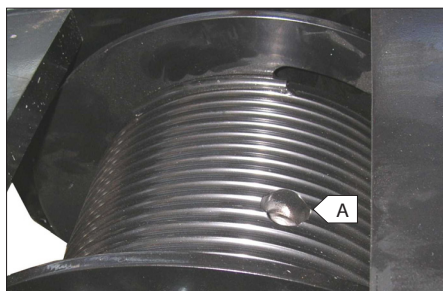

IT

FUNE, PULEGGIA e CAPOCORDA

Controllare giornalmente che la fune A (Fig.21) sia sempre in ottimo stato, che non ci siano filamenti rotti (Fig.21a) e che sia ben arrotolata sul tamburo B (Fig.21).

Altrimenti sostituirla con una nuova e dello stesso diametro e caratteristiche. Controllare la lubrificazione della fune, se necessita lubrificare con grasso industriale oppure olio sintetico anti-polvere.

Controllare giornalmente e mantenere lubrificato il perno C (Fig.21) su cui ruota la puleggia di guida D (Fig.21), che dovrà avere sempre un buono movimento di rotazione e di traslazione laterale.

Se necessita, lubrificare con grasso al sapone di litio il perno.

Assicurarsi dell'integrità dei capocorda E (Fig.22) e dei suoi morsetti fermafune F (Fig.22).

US

ROPE, PULLEY and TERMINAL

Check rope A daily (Fig.21) to make sure it is in perfect condition, that there are no broken filaments (Fig.21a) and that it is wound correctly around drum B (Fig.21).

If this is not the case, replace it with a new one having the same diameter and features.

Check the lubrication of the rope, and apply industrial grease or dust-proof synthetic oil, if necessary.

Check and lubricate pin C (Fig.21) on which guide pulley D (Fig.21) rotates, on a daily basis, making sure its rotation and transverse movements are smooth.

Lubricate the pin with lithium soap grease, if necessary.

Check the condition of terminal E (Fig.22) and its rope-holder clamps F (Fig.22).

NL

KABEL, KABELSCHIJF en KABELUITEINDEN

Controleer dagelijks of de kabel A (Fig.21) in optimale staat verkeert, of er geen draden stuk zijn (Fig.21a) en of hij goed op de trommel gewonden is B (Fig.21).

Vervang hem anders door een nieuwe met dezelfde diameter en eigenschappen.

Controleer de smering van de kabel, indien nodig smeren met industrieel vet of synthetische olie tegen stof.

Controleer dagelijks de pen C (Fig.21) waarop de geleideschijven D (Fig.21) draait en houd ze gesmeerd. Deze moet altijd een goede draai beweging en zijwaartse schuif beweging behouden.

Indien nodig, de pen invetten met lithi-umzeepvet.

Controleer de staat van de kabeluiteinden E (Fig.22) en de kabelklemmen F (Fig.22).

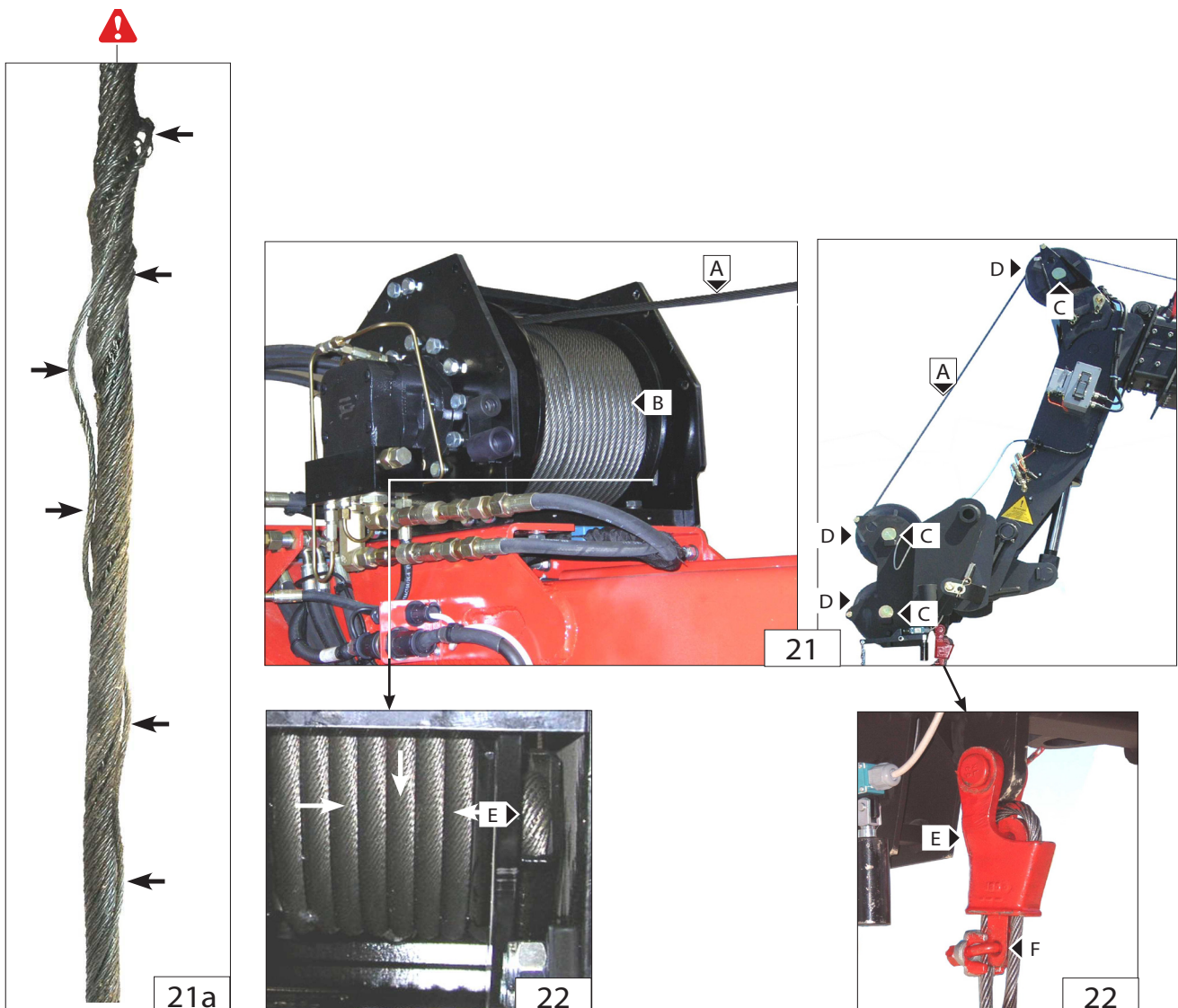

IT

BOZZELLO

Per una massima efficienza e sicurezza, mantenere intatta la struttura esterna H (Fig.23) e controllare che la puleggia L (Fig.24) ruoti correttamente sul suo perno M (Fig.24) .
Se necessità, lubrificare con grasso al sapone di litio il perno M (Fig.23).

GANCIO

Per una massima efficienza mantenere lubrificata la vite di rotazione del gancio N (Fig.24).
Senza carico sospeso, il gancio deve sempre ruotare liberamente e con la sola pressione della mano P (Fig.24).
Controllare lo stato e l'efficienza della linguetta di sicurezza O (Fig.24).

US

BLOCK

For maximum efficiency and safety, make sure the outer frame H (Fig.23) is intact and check pulley L (Fig.24) to make sure it rotates properly around its pin M (Fig.24) .
Lubricate pin M with lithium soap grease, if necessary (Fig.23).

HOOK

For maximum efficiency, keep the hook rotation screw N lubricated (Fig.24).
Without load suspended, the hook must rotate freely, merely by pressing with the hand P (Fig.24).
Check the condition and working of safety tab O (Fig.24).

NL

TAKEL

Voor een maximale efficiëntie en veiligheid, de buitenste structuur intact houden H (Fig.23) en controleren of de kabelschijf L (Fig.24) goed op zijn pen draait M (Fig.24).
Indien nodig, de pen M (Fig.23) invetten met lithiumzeepvet.

HAAK

Voor een maximale efficiëntie de draaischroef van de haak N (Fig.24) gesmeerd houden.
Zonder hangende lading moet de haak altijd vrij kunnen draaien door er met de hand tegenaan te drukken P (Fig.24).
Controleer de staat en de efficiëntie van de veiligheidssluiting O (Fig.24).

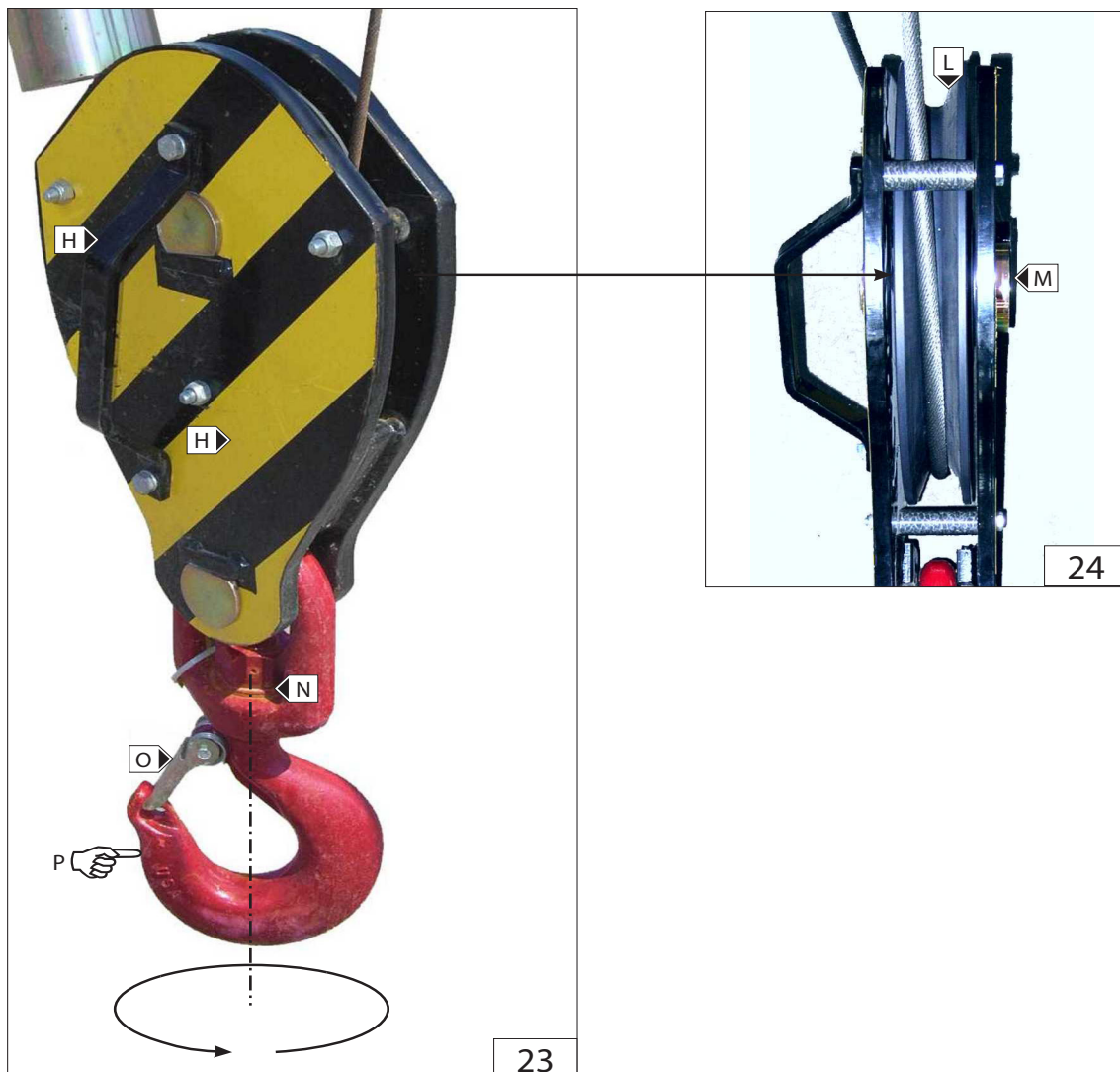

IT

FINE CORSA DISCESA FUNE (Fig.25)

Giornalmente per una massima efficienza mantenere sempre pulito il pistoncino e la valvola idraulica di sicurezza; controllare il serraggio dei raccordi e lo stato dei tubi. Inoltre verificare l'integrità del leveraggio di contatto fincorsa discesa e la tenuta della sua molla.

FINE CORSA SALITA FUNE

Giornalmente per una massima efficienza mantenere sempre pulito il pistoncino e il microinterruttore; controllare il collegamento elettrico. Inoltre verificare l'integrità del leveraggio di contatto fincorsa salita e la tenuta della sua molla. (Fig.26)

IMPIANTO IDRAULICO (Fig.27)

Ispezionare giornalmente raccordi, valvole, tubi, per evitare eventuali perdite di olio che compromettano il rendimento e la durata dell'argano.

US

ROPE DESCENT LIMIT STOP (Fig.25)

Keep the piston and hydraulic safety valve cleaned daily for maximum efficiency; check the unions and pipes to make sure they are tightened properly. Check the condition of the descent limit stop contact leverage and the seal on its spring.

ROPE LIFT LIMIT STOP

Keep the piston and safety microswitch cleaned daily for maximum efficiency; check the connection electrical. Also check the condition of the lift limit stop contact leverage and the seal on its spring. (Fig.26)

HYDRAULIC SYSTEM (Fig.27)

Inspect the unions, valves, pipes daily to prevent oil leakage which will affect the working and life of the winch.

NL

EINDAANSLAG KABEL OMLAAG (Fig.25)

Voor een maximale efficiëntie dagelijks altijd het zuigertje en het hydraulische veiligheidsventiel schoon houden; controleer of de verbindingen goed vast zitten en de staat van de leidingen. Controleer eveneens de staat van de hefbomen van de eindaanslag voor het dalen en zijn veer.

EINDAANSLAG KABEL OMHOOG

Voor een optimale efficiëntie dient u dagelijks het zuigertje en de microschakelaar schoon te maken en de elektrische aansluiting te controleren. Controleer eveneens de staat van de hefbomen van de eindaanslag voor het stijgen en zijn veer. (Fig.26)

HYDRAULISCHE INSTALLATIE (Fig.27)

Controleer dagelijks de verbindingstukken, kleppen en leidingen om eventuele olielekken te voorkomen die het rendement en de levensduur van de lier zouden kunnen beïnvloeden.

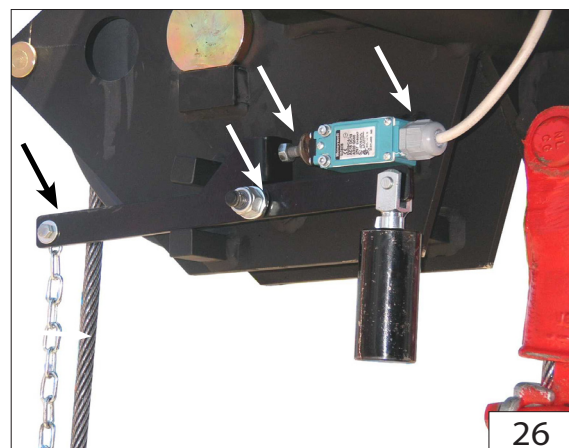
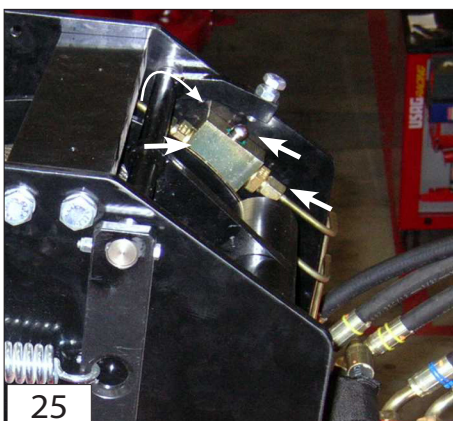
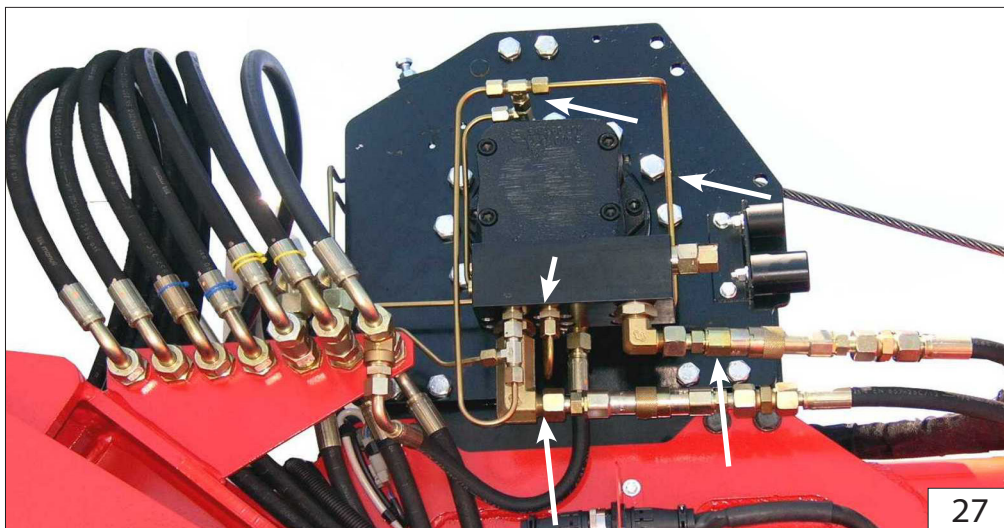



IT
SCHEMA IDRAULICO

US
HYDRAULIC DIAGRAM

NL
HYDRAULISCH SCHEMA

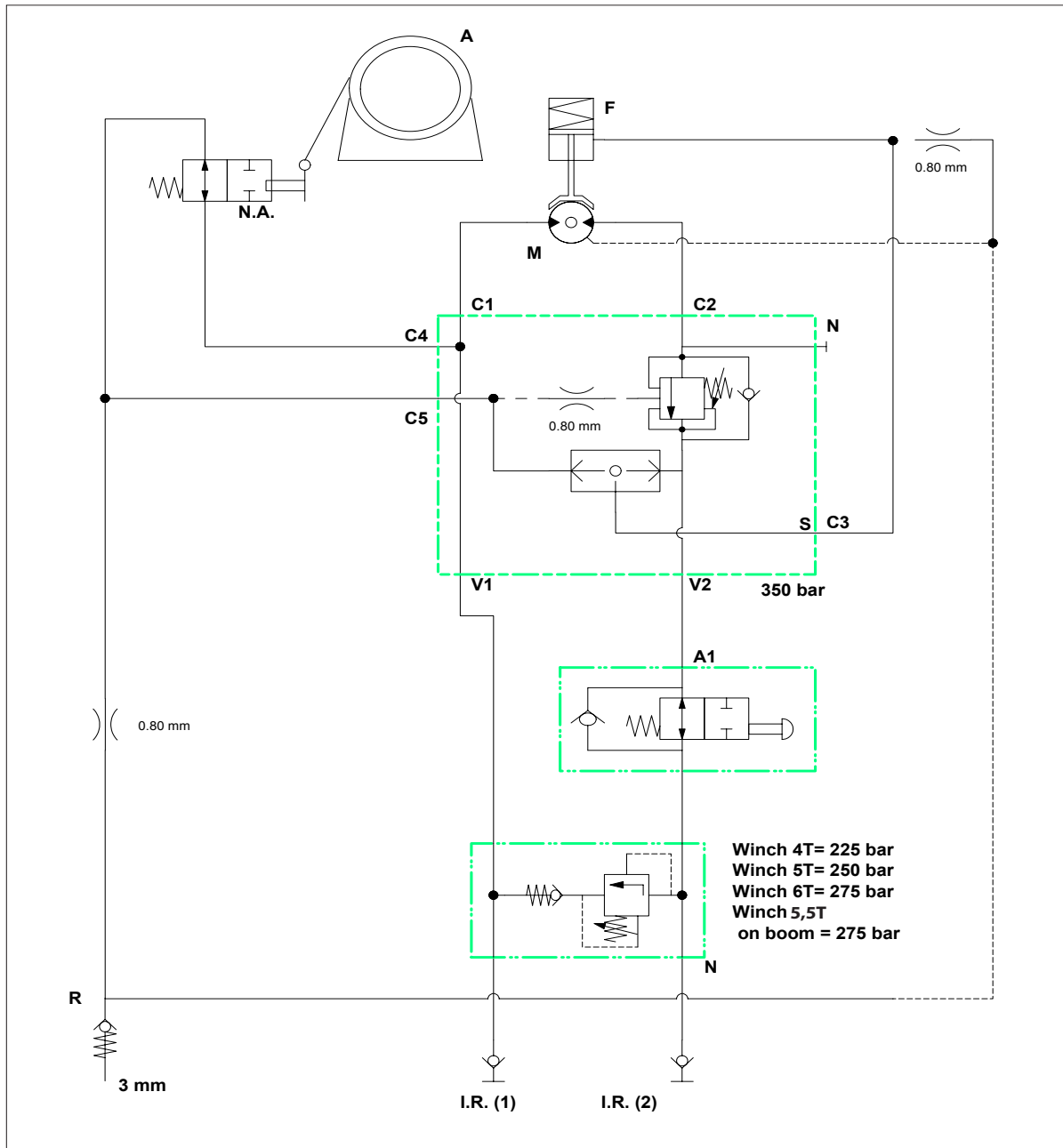

- A** = ARGANO
- N.A.** = MICRO MASSIMA DISCESA
- R** = SERBATOIO OLIO
- I.R.1** = INNESTO RAPIDO
- I.R.2** = INNESTO RAPIDO
- A1** = MICRO MASSIMA SALITA
- S** = VALVOLA
- N** = VALVOLA MASSIMA PRESSIONE
- M** = MOTORE
- F** = FRENO

- A** = WINCH
- N.A.** = MAX. DESCENT MICRO SWITCH
- R** = OIL TANK
- I.R.1** = QUICK-RELEASE COUPLING
- I.R.2** = QUICK-RELEASE COUPLING
- A1** = MAX. ASCENT MICRO SWITCH
- S** = VALVE
- N** = PRESSURE RELIEF VALVE
- M** = MOTOR
- F** = FRENO

- A** = LIER
- N.A.** = MICRO MAXIMALE DALING
- R** = OLJETANK
- I.R.1** = SNELKOPPELING
- I.R.2** = SNELKOPPELING
- A1** = MICRO MAXIMALE STIJGING
- S** = VENTIEL
- N** = MAXIMUMDRUKVENTIEL
- M** = MOTOR
- F** = REM



Questa pagina è intenzionalmente vuota
This page is left blank intentionally
Deze pagina is opzettelijk leeg gelaten



P 600



IT

Descrizione:

Braccetto lungo 4mt con una portata di 600Kg.

US

Description:

4m long arm with carrying capacity of 600 kg.

NL

Beschrijving:

4 m lange arm met een draagvermogen van 600 kg.





[kg] (lb)	[t] (t)	[mm] (in)								[kg] (lb)
600 (1322)	5 (5)	A	B	C	D	E	F	G	H	395 (870)
		1810 (71)	900 (35)	506 (20)	730 (29)	353 (14)	270 (11)	750 (29)	750 (29)	

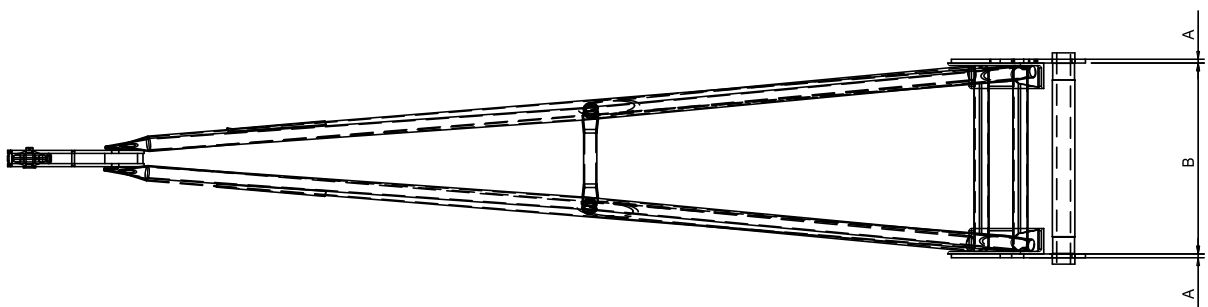
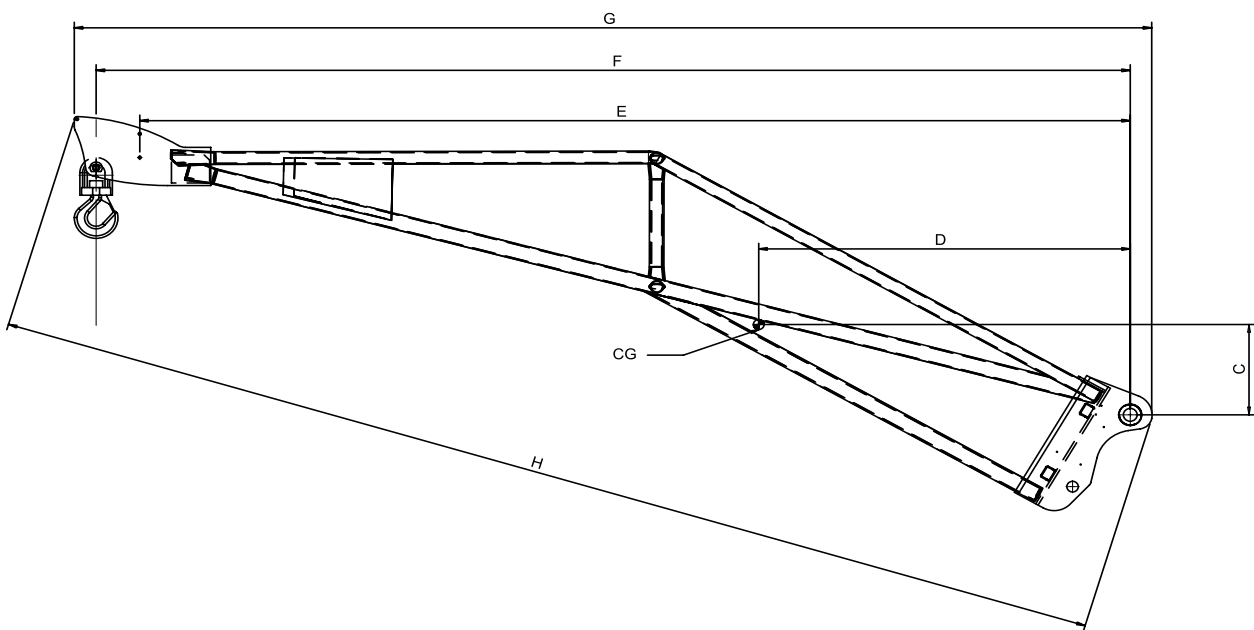



Questa pagina è intenzionalmente vuota
This page is left blank intentionally
Deze pagina is opzettelijk leeg gelaten



P 1000



IT

Descrizione:

Braccetto lungo 4mt con una portata di 1000Kg.

US

Description:

4m long arm with carrying capacity of 1000 kg.





NL

Beschrijving:

4 m lange arm met een draagvermogen van 1000 kg.





[kg] (lb)	[t] (t)	[mm] (in)									[kg] (lb)
											
1000 (2204)	5 (5)	A	B	C	D	E	F	G	H	I	210 (463)
		750 (29)	15 (0,5)	355 (13,9)	353 (13,8)	1361 (53)	3630 (143)	3790 (149)	3948 (155)	4119 (162)	

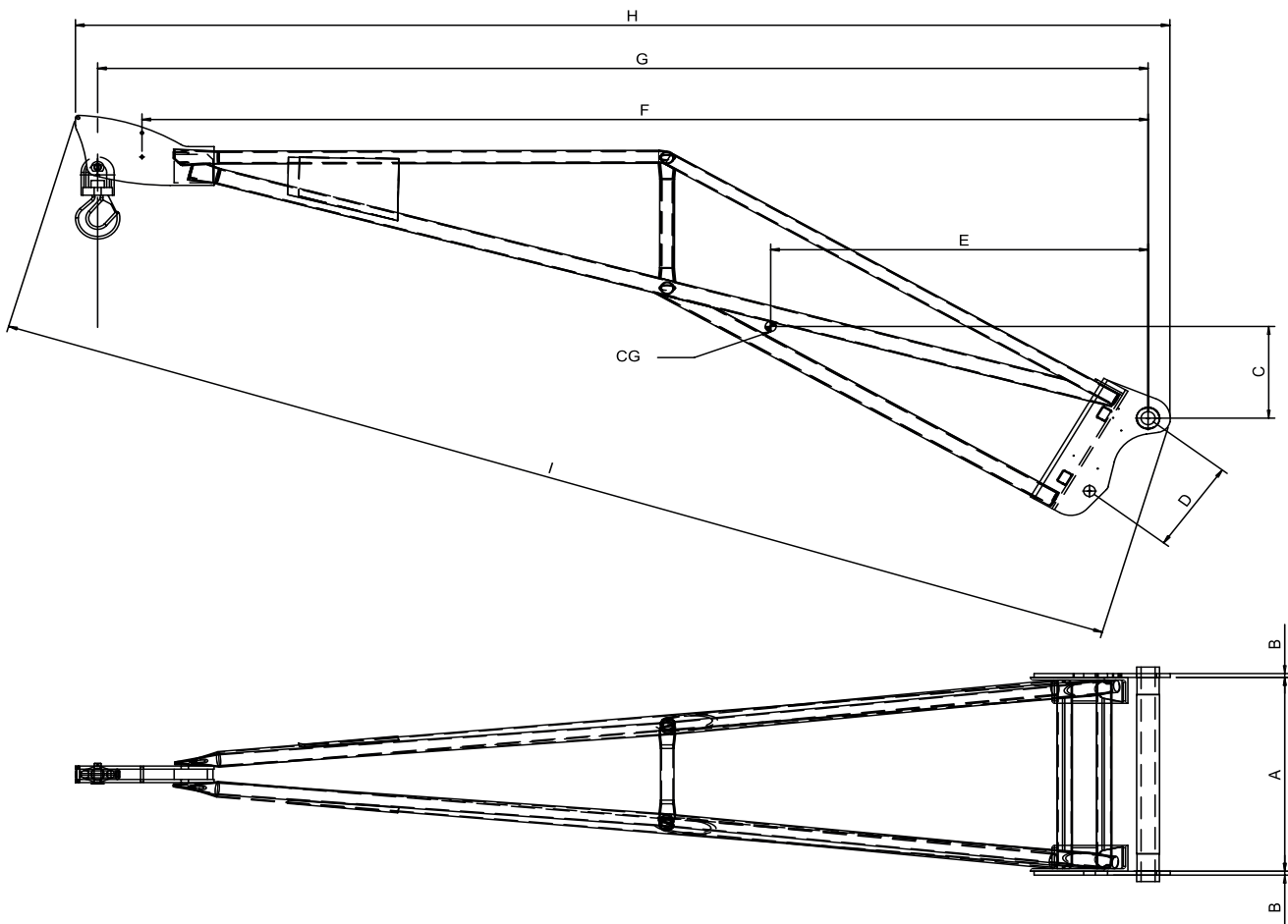



Questa pagina è intenzionalmente vuota
This page is left blank intentionally
Deze pagina is opzettelijk leeg gelaten



P 1200



IT

Descrizione:

Braccetto lungo 3mt con una portata di 1200Kg.

US

Description:

3m long arm with carrying capacity of 1200 kg.

NL

Beschrijving:

3 m lange arm met een draagvermogen van 1200 kg.





[kg] (lb)	[t] (t)	[mm] (in)									[kg] (lb)
1200 (2645)	5 (5)	A	B	C	D	E	F	G	H	I	150 (330)
		750 (29)	15 (0,5)	2950 (116)	353 (13,8)	228 (9)	965 (38)	2500 (98)	2660 (105)	2819 (111)	

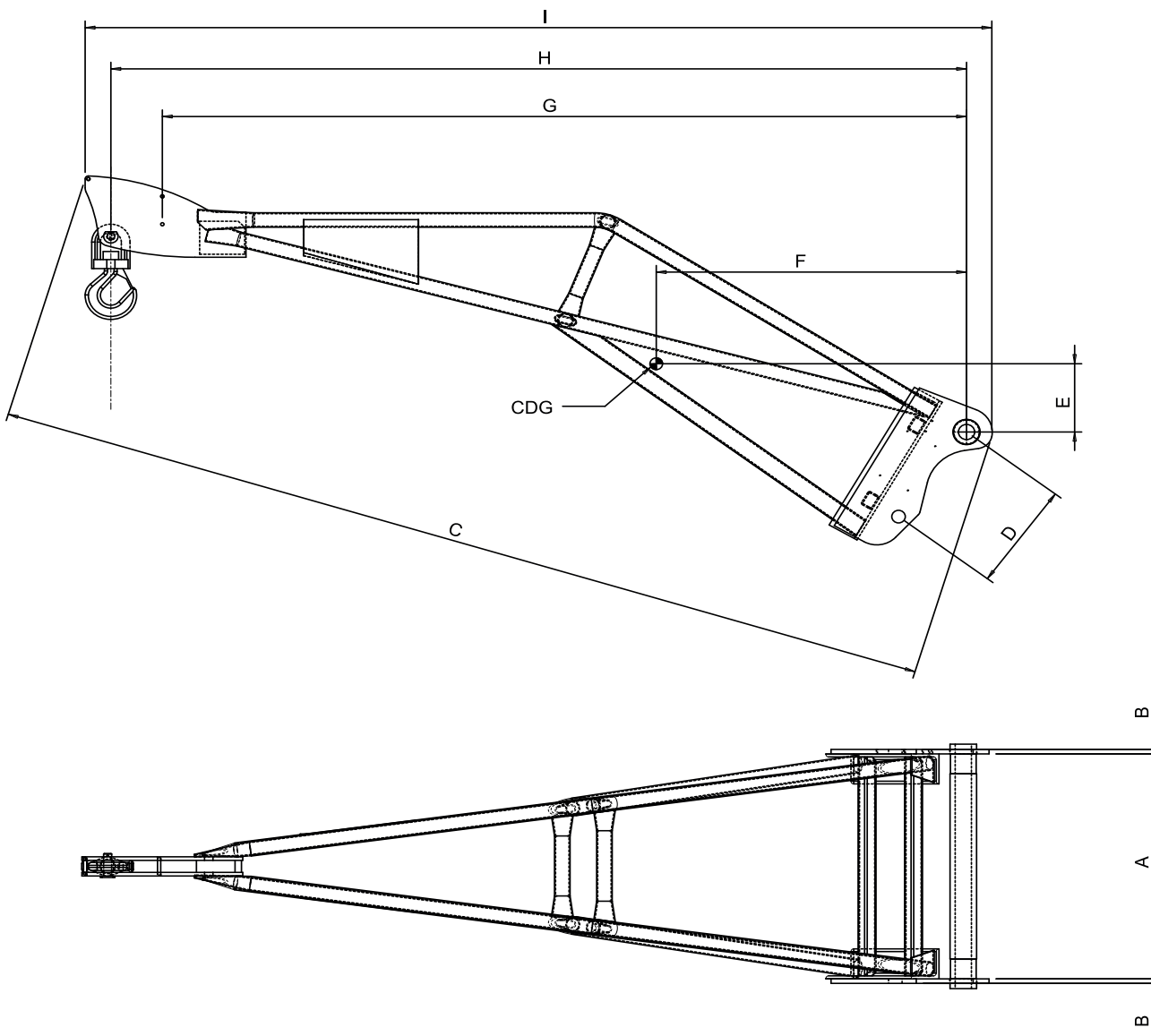



Questa pagina è intenzionalmente vuota
This page is left blank intentionally
Deze pagina is opzettelijk leeg gelaten



P 1500



IT

Descrizione:

Braccetto lungo 3mt con una portata di 1500Kg.

US

Description:

3m long arm with carrying capacity of 1500 kg.

NL

Beschrijving:

3 m lange arm met een draagvermogen van 1500 kg.





[kg] (lb)	[t] (t)	[mm] (in)									[kg] (lb)
1500 (3306)	5 (5)	A	B	C	D	E	F	G	H	I	186 (410)
		750 (29)	15 (0,5)	2950 (116)	353 (13,8)	228 (9)	965 (38)	2500 (98)	2660 (105)	2819 (111)	

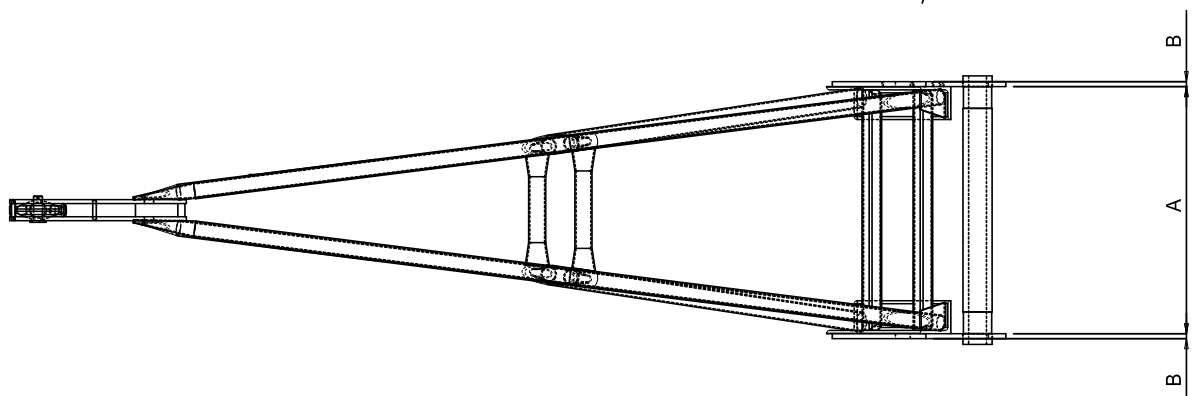
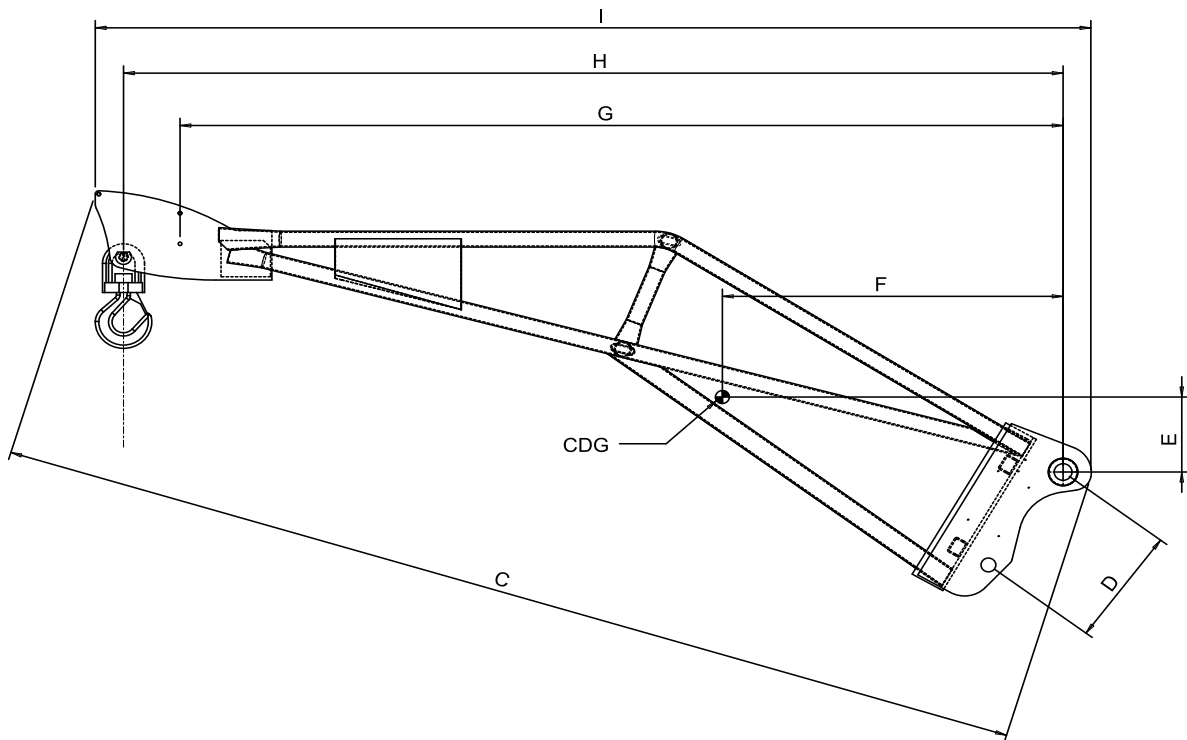



Questa pagina è intenzionalmente vuota
This page is left blank intentionally
Deze pagina is opzettelijk leeg gelaten



P 2000



IT

Descrizione:

Braccetto lungo 2,5mt con una portata di 2000Kg.

US

Description:

2.5m long arm with carrying capacity of 2000 kg.

NL

Beschrijving:

2,5 m lange arm met een draagvermogen van 2000 kg.





[kg] (lb)	[t] (t)	[mm] (in)									[kg] (lb)
1500 (3306)	5 (5)	A	B	C	D	E	F	G	H	I	186 (410)
		750 (29)	15 (0,5)	2950 (116)	353 (13,8)	228 (9)	965 (38)	2500 (98)	2660 (105)	2819 (111)	

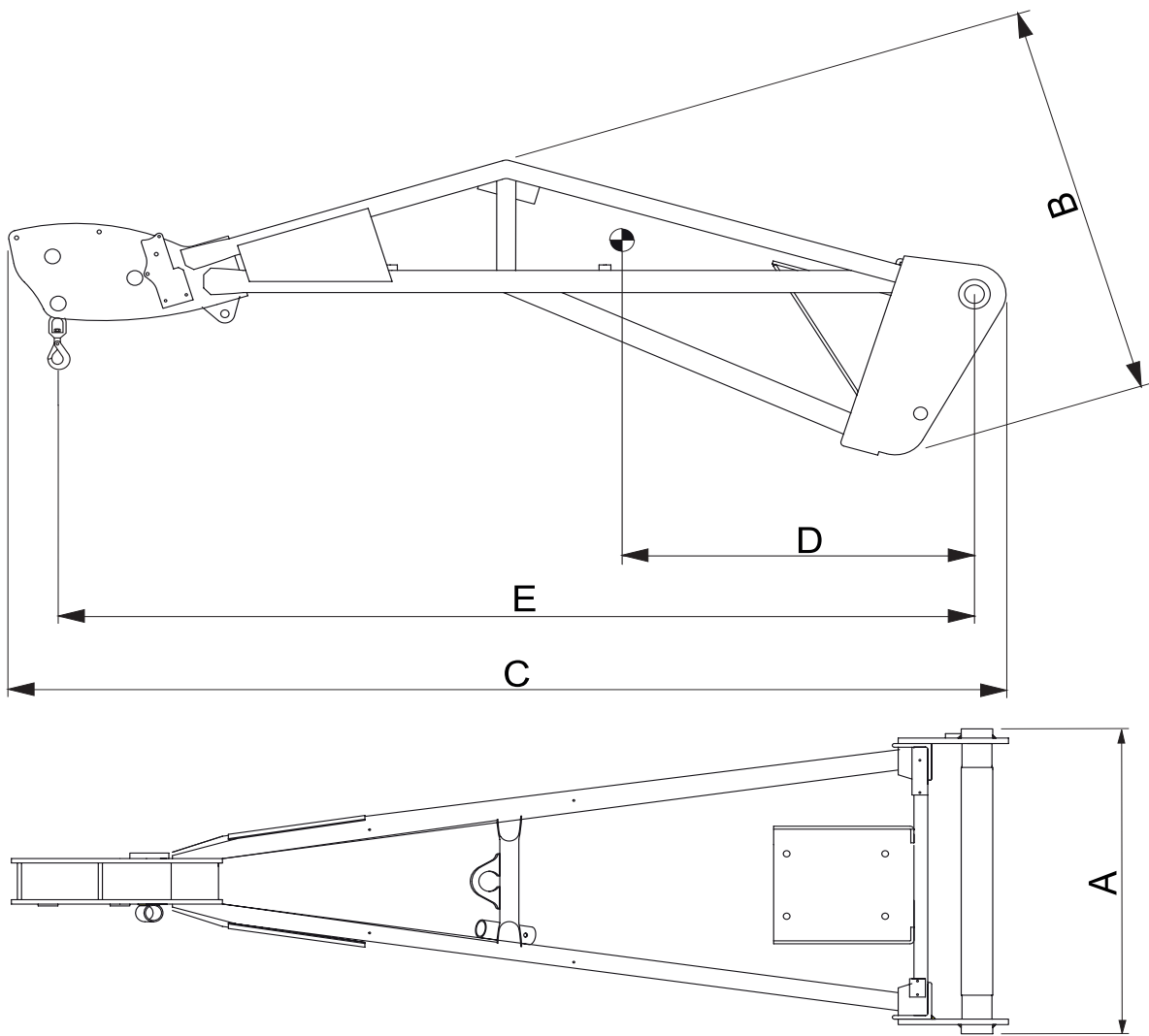



Questa pagina è intenzionalmente vuota
This page is left blank intentionally
Deze pagina is opzettelijk leeg gelaten



P 4000

IT

Descrizione:

Braccetto lungo 2,7 m con due portate:
4000 kg a 0.70 m e 1200 kg a 2,7 m.

US

Description:

2.7 m long arm with two carrying
capacities:
4000 kg at 0.70 m and 1200 kg at 2.7 m

NL

Beschrijving:

2,7 m lange arm met twee
draagvermogens: 4000 kg op 0.70 m en
1200 kg op 2,7 m.





[kg] (lb)	[t] (t)	[kg] (lb)	[t] (t)	[mm] (in)										[kg] (lb)
•	◆													
1200 (2645)	3 (3)	4000 (8818)	4 (4)	A	B	C	D	E	F	G	H	I	L	210 (463)

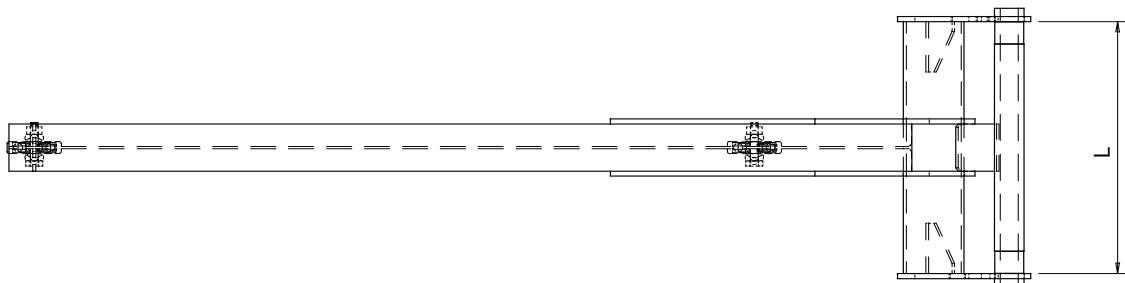
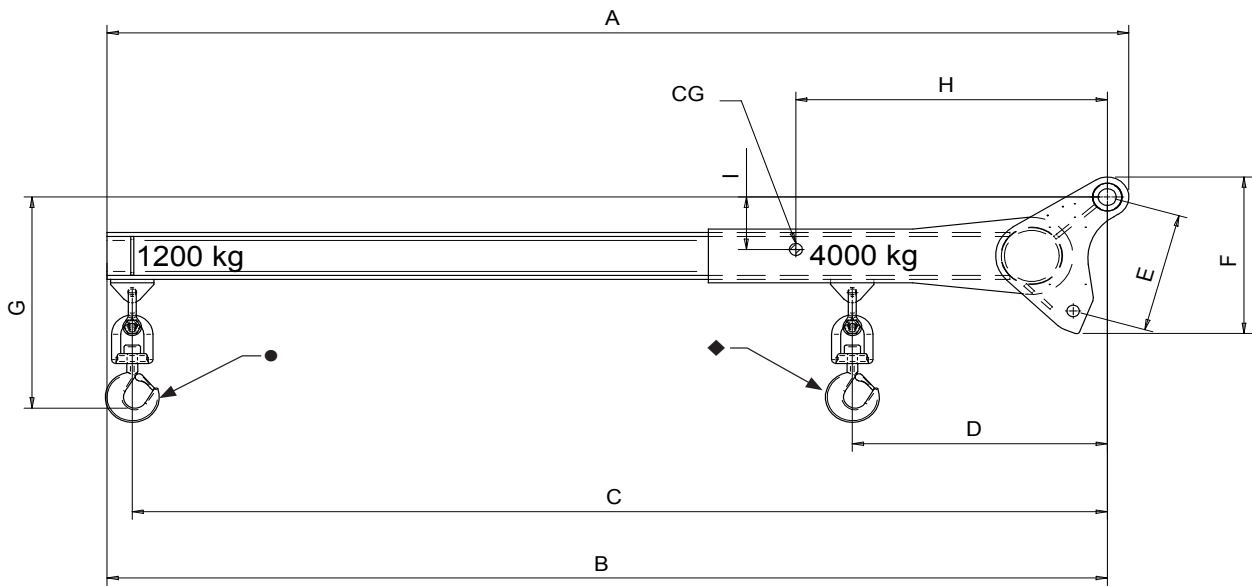



Questa pagina è intenzionalmente vuota
This page is left blank intentionally
Deze pagina is opzettelijk leeg gelaten



P 6000

IT

Descrizione:

Braccetto lungo 2,7 m con due portate:
6000 kg a 0.80 m e 2000 kg a 2,7 m.

US

Description:

2.7 m long arm with two carrying
capacities:
6000 kg at 0.80 m and 2000 kg at 2.7 m

NL

Beschrijving:

2,7 m lange arm met twee
draagvermogens: 6000 kg op 0.80 m en
2000 kg op 2,7 m.





[kg] (lb)	[t] (t)	[kg] (lb)	[t] (t)	[mm] (in)										[kg] (lb)
•	◆	A	B	C	D	E	F	G	H	I	L	210 (463)		
3000 (6614)	3 (3)	6000 (13227)	6 (6)	2838 (112)	2778 (109)	2708 (107)	808 (32)	352 (13,8)	466 (18)	649 (25)	950 (37)	156 (6)	750 (29)	210 (463)

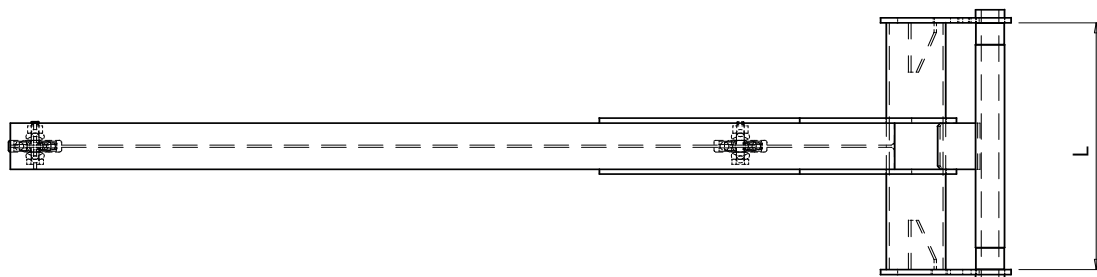
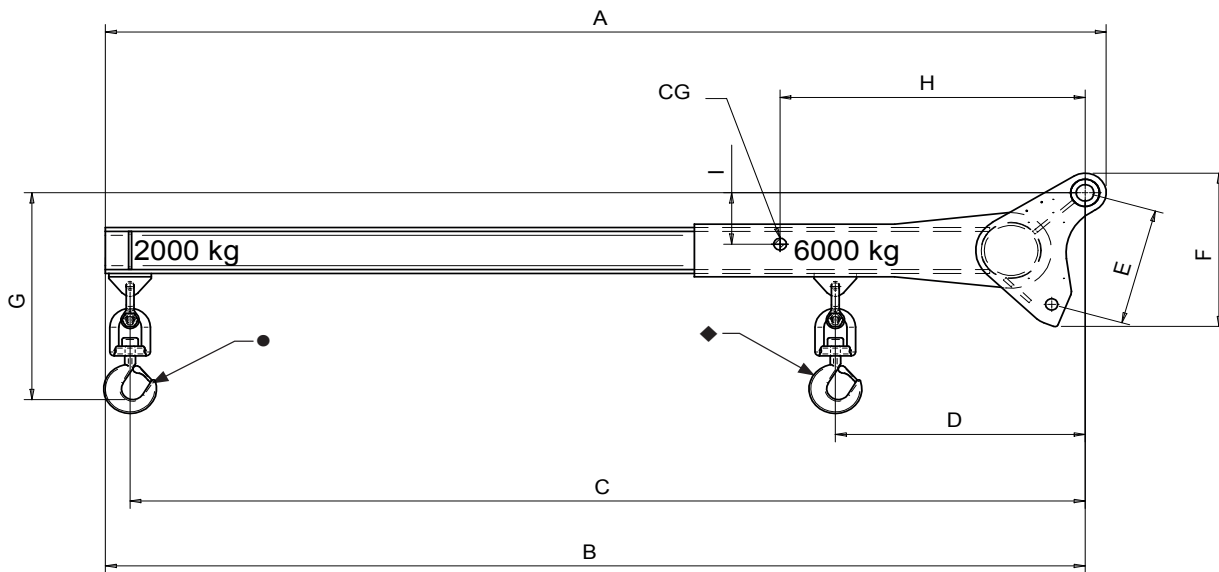



Questa pagina è intenzionalmente vuota
This page is left blank intentionally
Deze pagina is opzettelijk leeg gelaten



PT 600

IT

Descrizione:

Braccetto lungo 4mt con argano portata 600Kg.

Caratteristiche:

- Tiro al 2° strato di 600Kg.
- Velocità massima al 2° strato 89mt/min
- Il tiro è diretto
- La fune è di 40mt, diametro 6mm disposta su due strati..
- Motore orbitale Sauer-Danfoss OMRS80.
- Riduttore epicicloidale con freno negativo a dischi in bagno d'olio.
- Il tamburo è filettato e dotato di un rullo pressa fune in modo da assicurare sempre un corretto avvolgimento della fune.
- Classificazione ISO 4301/1: T4,L2,M4.

Sicurezze:

- Fine corsa discesa idraulico positivo.
- Fine corsa salita idraulico positivo.

US

Description:

4m long arm with carrying capacity of 600 kg.

Features:

- Pull at 2nd layer 600kg.
- Maximum speed at 2nd layer 89 m/min
- The pull is direct
- The rope is 40 m long, 6mm diameter arranged in two layers.
- Sauer-Danfoss OMRS80 orbital motor
- Planetary drive with negative oil bath disk brake
- The drum is threaded and provided with a rope press roller in order to always ensure correct winding of the rope.
- ISO 4301/1 Classification: T4, L2, M4.

Safety devices:

- Positive hydraulic descent limit switch.
- Positive hydraulic ascent limit switch.

NL

Beschrijving:

4 m lange arm met lier met draagvermogen van 600 kg.

Kenmerken:

- Trekkracht 2de laag 600 kg.
- Maximumsnelheid 2de laag 89 m/min.
- Kabel enkel gebruikt.
- De kabel is 40 m, diameter 6 mm in twee lagen.
- Sauer-Danfoss OMRS80 orbitmotor.
- Planetaire reductor met negatieve schijvenrem in oliebad.
- De trommel is gegleufd en voorzien van een kabelaandrukrol voor een altijd correcte opwikkeling van de kabel.
- Classificatie ISO 4301/1: T4,L2,M4.

Beschermingen:

- Positieve hydraulische eindaanslag daling.
- Positieve hydraulische eindaanslag stijging.





[kg] (lb)	[t] (t)	[mm] (in) x [m] (ft)	[m/min] (ft/min)	[bar] (psi)	[mm] (in)									[kg] (lb)
				P max										
600 (1322)	5 (5)	Ø 6 (0,2) x 40 (131)	89 (292)	200 (2900)	A	B	C	D	E	F	G	H	I	278 (613)
					4104 (161)	3831 (151)	15 (0,5)	25 (0,9)	780 (31)	830 (33)	100 (4)	1079 (42)	1153 (45)	

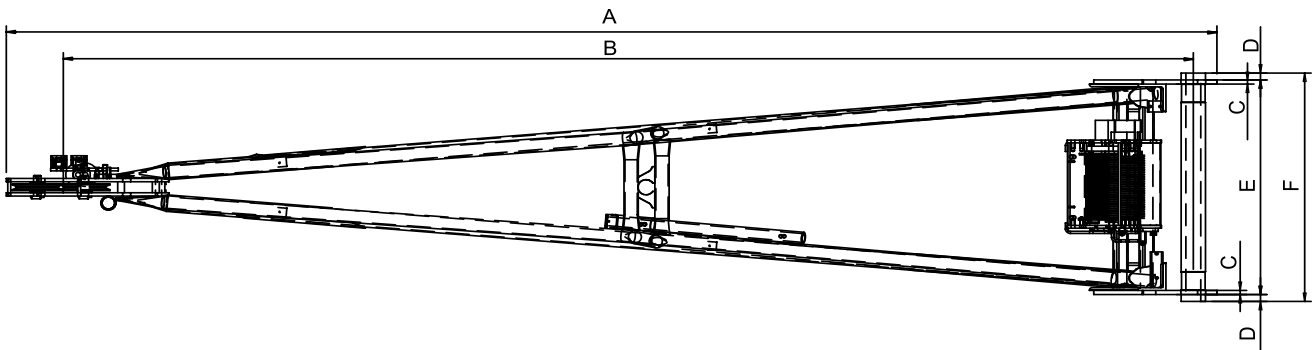
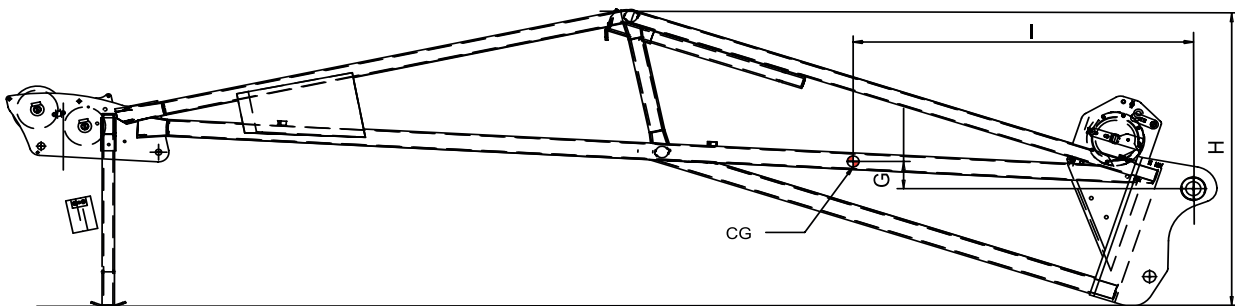

IT

PT 600

MESSA IN SERVIZIO E UTILIZZO

Per la vostra sicurezza, prima di iniziare un ciclo di lavoro, attenersi alle Istruzioni obbligatorie di verifica e controllo:

- verificare l'integrità della struttura esterna dell'argano e del braccetto tralicciato.
- verificare il corretto collegamento idraulico degli innesti rapidi 1, 2, Drenaggio e lo stato dei tubi flessibili (Fig.1);
- controllare il corretto funzionamento del fine corsa discesa fune L (Fig.2);
- controllare il corretto funzionamento del fine corsa salita fune H (Fig.2);

US

PT 600

STARTING UP AND USE

For your safety, before starting a work cycle, follow the Compulsory instructions for inspection and control:

- check to make sure the external structure of the winch and latticed boom is intact.
- Check to ensure the correct hydraulic connection of quick-release couplings 1, 2, drainage and the condition of the hose pipes (Fig.1);
- check to ensure correct working of the rope ascent limit switch L (Fig.2);
- check to ensure correct working of the rope descent limit switch H (Fig.2);

NL

PT 600

INBEDRIJFSTELLING EN GEBRUIK

Houd u, voor uw eigen veiligheid, voor met een werkcyclus aan te vangen, aan de **verplichte controle-instructies**:

- controleer of de buitenste structuur van de lier en van de vakwerkarm intact is.
- controleer of de hydraulische verbinding van de snelkoppelingen 1, 2, Afvoer en de staat van de slangen in orde zijn (Fig.1);
- controleer de werking van de eindaanslag kabel omlaag L (Fig.2);
- controleer de werking van de eindaanslag kabel omhoog H (Fig.2);

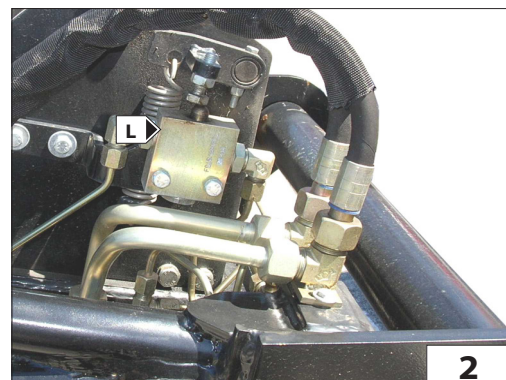
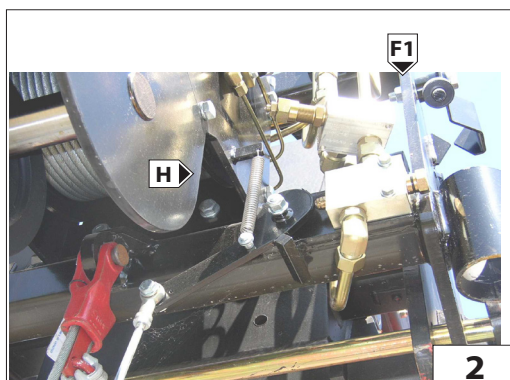
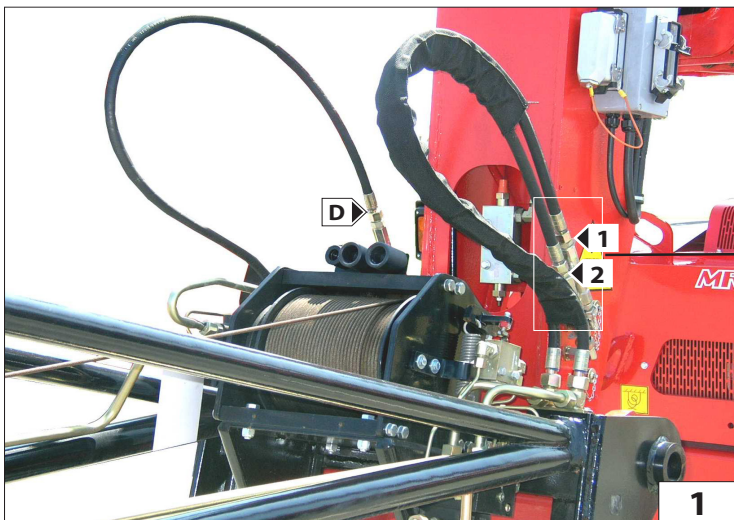

IT

- controllare lo stato della fune B (Fig.3) e il corretto avvolgimento sul tamburo A (Fig.3);
- controllare il corretto movimento rotazione delle pulegge di guida fune F1 (Fig.2);
- controllare lo stato del capocorda C (Fig.3);
- controllare che il grillo di collegamento fune e gancio sia ben avvitato K (Fig.4) e che i morsetti K1 (Fig.4) bloccino la fune.
- verificare lo stato del gancio: che non sia deformato, che ruoti liberamente e che la linguetta di sicurezza sia efficiente G (Fig.4);
- controllare l'aggancio del braccetto alla macchina operatrice J (Fig.5).

US

- check the condition of the rope B (Fig. 3) and that it is wound correctly on the drum A (Fig.3);
- check to ensure correct rotation movement of the rope guide pulley F1 (Fig. 2);
- check the condition of cable terminal C (Fig. 3);
- check to make sure the rope and hook connecting shackle is screwed in properly K (Fig.4) and that the terminals K1 (Fig.4) block the rope;
- check the condition of the hook: to make sure it is not deformed, that it rotates freely and that the safety tab G (Fig. 4) is in working order;
- check the hook-up of the boom to the operating machine J (Fig. 5).

NL

- controleer de staat van de kabel B (Fig.3) en de opwikkeling op de trommel A (Fig.3);
- controleer de draaibeweging van de kabelgeleidewielen F1 (Fig.2);
- controleer de staat van het kabeluiteinde C (Fig.3);
- controleer of de harpsluiting tussen de kabel en de haak K (Fig.4) goed vastgedraaid is en of de klemmen K1 (Fig.4) de kabel blokkeren.
- controleer de staat van de haak: of deze niet vervormd is, of hij vrij draait en of zijn veiligheidssluiting efficiënt is G (Fig.4);
- controleer de aankoppeling van de arm aan de machine J (Fig.5).

Dalla posizione di parcheggio è possibile sganciare il piede di appoggio e posizionarlo all'interno del braccetto per operare senza ulteriori ingombri J1 (Fig.5).

From the parking position it is possible to unhook the foot and position it inside the boom to operate without increasing the dimensions J1 (Fig.5).

Vanuit de parkeerstand kan de steunpoot losgemaakt worden en binnenin de arm geplaatst worden om zonder onnodige ruimte innemende structuren te kunnen werken J1 (Fig.5).

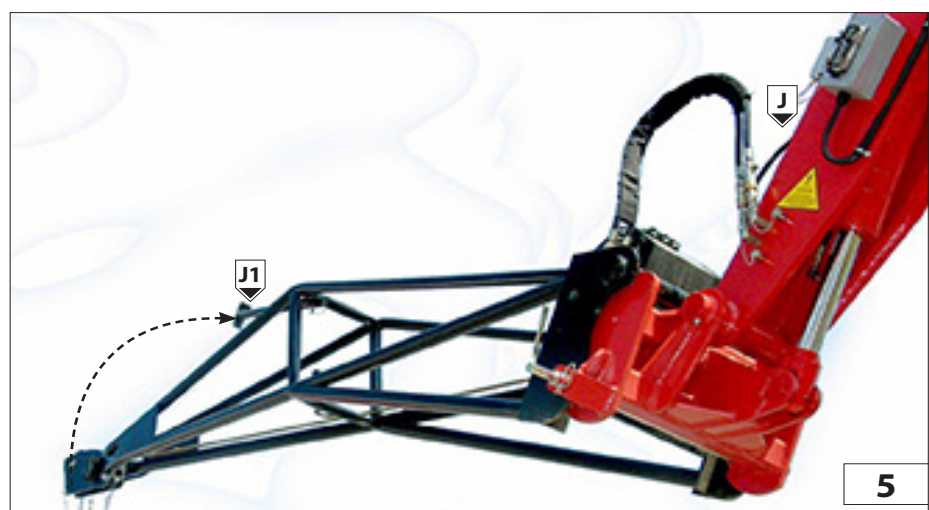
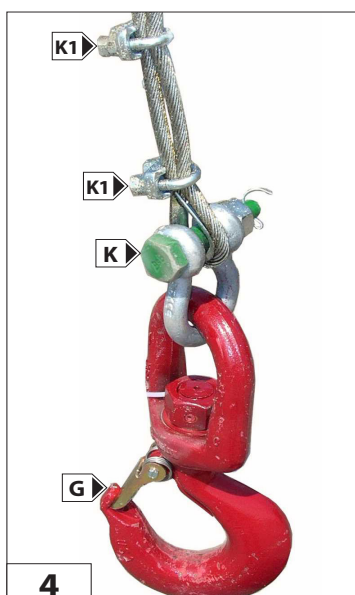
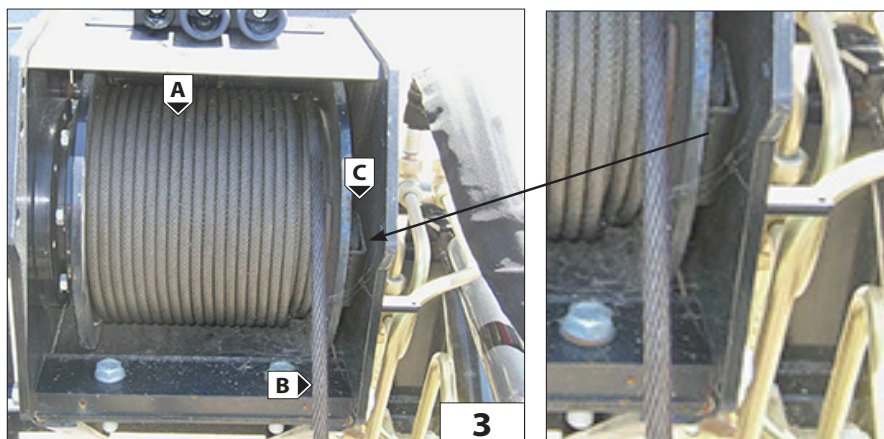



IT

MANUTENZIONE

- RIDUTTORE
- FUNE, PULEGGIA E CAPOCORDA
- BOZZELLO
- GANCIO
- FINE CORSA DISCESA FUNE
- FINE CORSA SALITA FUNE
- IMPIANTO IDRAULICO

US

MAINTENANCE

- REDUCTION GEAR
- ROPE, PULLEY AND CABLE TERMINAL
- PULLEY BLOCK
- HOOK
- ROPE DESCENT LIMIT SWITCH
- ROPE ASCENT LIMIT SWITCH
- HYDRAULIC SYSTEM

NL

ONDERHOUD

- REDUCTOR
- KABEL, KABELSCHIJF en KABELUI-
TEINDEN
- TAKEL
- HAAK
- EINDAANSLAG KABEL OMLAAG
- EINDAANSLAG KABEL OMHOOG
- HYDRAULISCH CIRCUIT



IT

RIDUTTORE

Una corretta lubrificazione consente un buon funzionamento e una lunga durata del riduttore.

Per accedere all'indicatore di livello o al tappo di rabbocco olio, occorre srotolare completamente la fune dal tamburo.

Controllare il livello dell'olio ogni 100 ore A (Fig.6b) e all'occorrenza rabboccare A (Fig.6b) con olio dello stesso tipo di quello presente all'interno del riduttore (SHELL SPIRAX HD80 W90).

Si consiglia l'utilizzo di olio per ingranaggi con additivazione EP con viscosità SAE 80W/90 oppure SAE 85W/140.

La prima sostituzione dell'olio deve essere effettuata dopo 150 ore di funzionamento, successivamente ogni 1000 ore di funzionamento.

Eseguire il cambio dell'olio con riduttore ancora caldo per facilitare un completo svuotamento.

Per scaricare l'olio, ruotare il tamburo del motore portando il tappo di rabbocco / scarico A (Fig.6a) verso il basso. Svitare il tappo A (Fig.6a) e scaricare completamente l'olio.

Ruotare il tamburo portando il foro di rabbocco/scarico sull'asse orizzontale A (Fig.6b).

Rabboccare con olio nuovo e di tipo corretto fino a quando l'olio non fuoriesce da foro di livello A (Fig.6b). (0,6 lt)
Riavvitare i tappi e riavvolgere la fune.

US

REDUCTION GEAR

Correct lubrication allows proper working and longer life of the reduction gear.

To access the level indicator or oil topping up cap, the rope must be unwound completely from the drum.

Check the oil level at least every 100 hours A (Fig.6b) and if required, top up A (Fig.6b) with oil of the same type as that present inside the reduction gear (SHELL SPIRAX HD80 W90).

Use gear oil with additive EP with viscosity SAE 80W/90 or SAE 85W/140.

The first oil change must be after 150 hours of operation, then subsequently every 1000 hours of operation.

Change the oil with the reduction gear still hot to allow complete drainage.

To drain the oil, turn the engine drum so that the filler/drainage cap A (Fig. 6a) is facing downwards.

Unscrew cap A (Fig.6a) and drain out the oil completely.

Turn the drum to bring the topping up/drainage hole horizontal A (Fig.6b).

Top up with fresh oil of the correct type until the oil flows out through the level hole A (Fig.6b).(0.6 l).

Screw the cap back on and rewind the rope.

NL

REDUCTOR

Een correcte smering maakt een goede werking en een lange levensduur van de reductor mogelijk.

Om toegang te verkrijgen tot de oliepeilindicator of de oliebijkuldop, moet de kabel helemaal van de trommel gerold worden.

Controleer het oliepeil om de 100 uren A (Fig.6b) en indien nodig bijvullen A (Fig.6b) met olie van hetzelfde soort als dat aanwezig is in de reductor (SHELL SPIRAX HD80 W90).

Er wordt aangeraden olie voor tandwielen te gebruiken met additievering van EP met viscositeit SAE 80W/90 of SAE 85W/140.

De eerste olieversing moet na 150 werkuren plaatsvinden, daarna om de 1000 werkuren.

Ververs de olie met nog warme reductor om een complete leging te vergemakkelijken.

Om de olie af te voeren, de trommel van de motor zodanig draaien dat de bijvul/aftapdop A (Fig.6a) naar beneden staat.

Draai de dop A (Fig.6a) los en laat alle olie weglopen.

Draai de trommel zodanig dat de bijvul-/aftapopening op de horizontale as staat A (Fig.6b).

Vul bij met nieuwe olie van het juiste type totdat de olie door de oliepeilopening naar buiten komt A (Fig.6b). (0,6 l)
Draai de doppen weer vast en wikkel de kabel weer op.

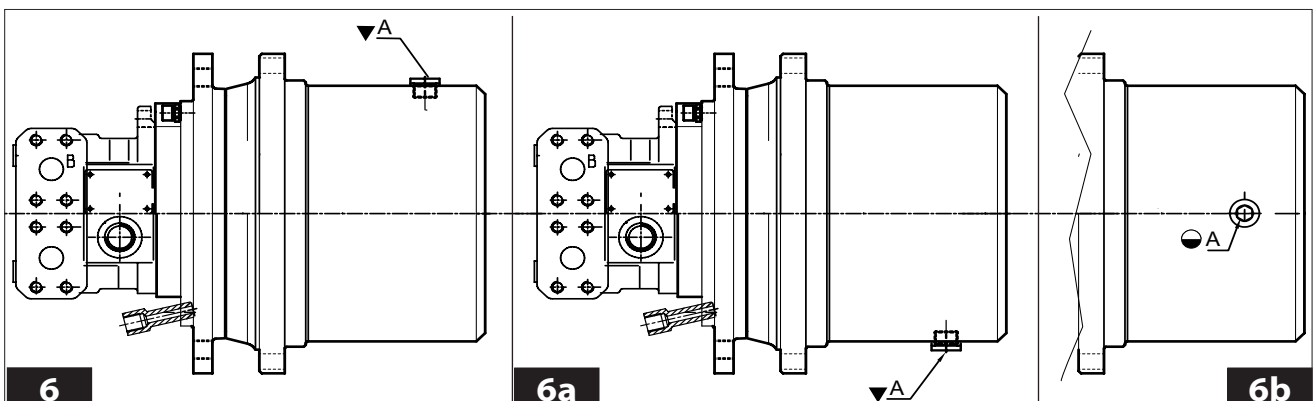
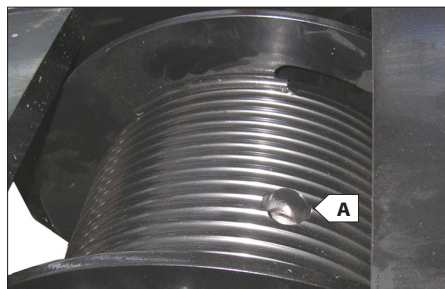

IT

FUNE, PULEGGIA e CAPOCORDA

Controllare giornalmente che la fune A (Fig.7) sia sempre in ottimo stato, che non ci siano filamenti rotti (Fig.7a) e che sia ben arrotolata sul tamburo B (Fig.7).

Altrimenti sostituirla con una nuova e dello stesso diametro e caratteristiche. Controllare la lubrificazione della fune, se necessita lubrificare con grasso industriale oppure olio sintetico anti-polvere.

Controllare e mantenere lubrificato i perni C (Fig.8) su cui ruotano le pulegge di guida D (Fig.8), che dovranno avere sempre un buono movimento di rotazione.

Se necessita, lubrificare con grasso al sapone di litio il perno.

Assicurarsi dell'integrità dei capocorda E (Fig.9) e dei suoi morsetti fermafune.

US

ROPE, PULLEY AND CABLE TERMINAL

Check daily to make sure the rope A (Fig.7) is always in excellent condition, that it is not frayed (Fig.7a) and that it is wound perfectly around the drum B (Fig.7).

If necessary replace with a new rope having the same diameter and features. Check the lubrication of the rope, if necessary, lubricate with industrial grease or dust-proof synthetic oil.

Check and lubricate the pins C (Fig. 8) on which the guide pulleys D (Fig. 8) rotate and these must always rotate perfectly. If necessary, lubricate the pin with lithium soap grease.

Ensure the integrity of the cable terminals E (Fig.9) and the rope retainer clamps.

NL

KABEL, KABELSCHIJF en KABELUITEINDEN

Controleer dagelijks of de kabel A (Fig.7) in optimale staat verkeert, of er geen draden stuk zijn (Fig.7a) en of hij goed op de trommel gewonden is B (Fig.7).

Vervang hem anders door een nieuwe met dezelfde diameter en eigenschappen.

Controleer de smering van de kabel, indien nodig smeren met industrieel vet of synthetische olie tegen stof.

Controleer de pennen C (Fig.8) waarop de geleideschijven D (Fig.8) draaien en houd ze gesmeerd. Deze moet altijd een goede draibeweging behouden. Indien nodig, de pen invetten met lithiumzeepvet.

Controleer de staat van de kabeluiteinden E (Fig.9) en de kabelklemmen.

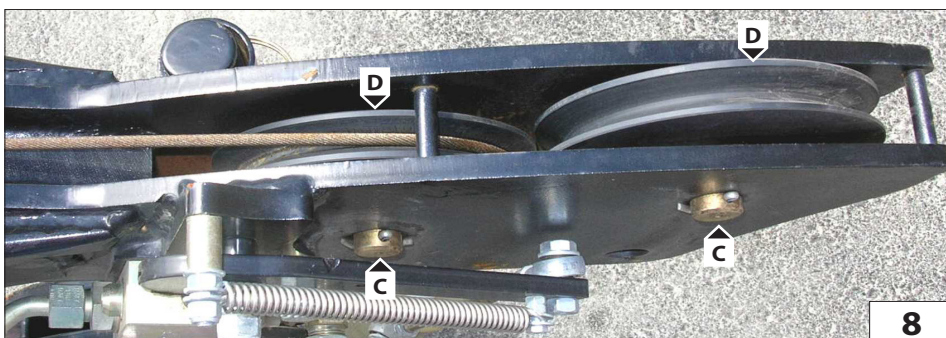
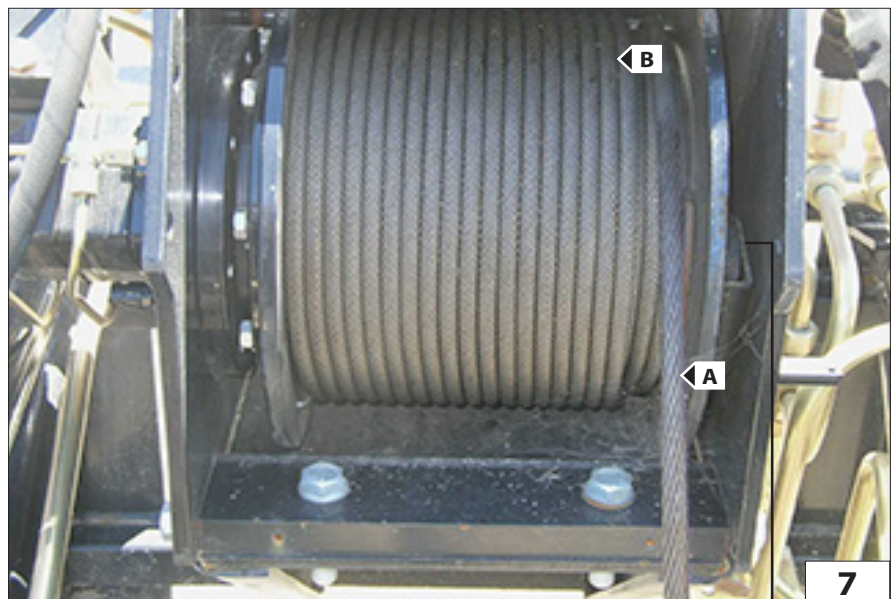
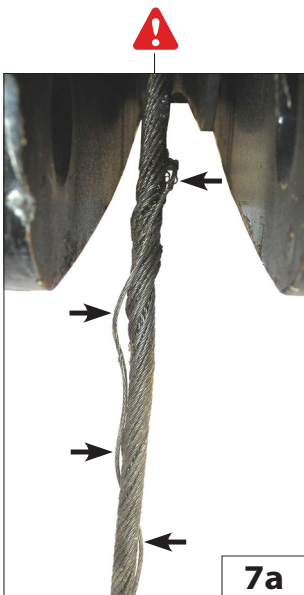

IT

GRILLO E MORSETTI

È importante verificare l'integrità e il serraggio delle viti dei morsetti F (Fig.10) e del bullone del grillo G (Fig.10) una volta alla settimana.

GANCIO

Per una massima efficienza mantenere lubrificata la vite di rotazione del gancio N (Fig.10).

Senza carico sospeso, il gancio deve sempre ruotare liberamente e con la sola pressione della mano P (Fig.10). Controllare lo stato e l'efficienza della linguetta di sicurezza O (Fig.10).

US

SHACKLE AND TERMINALS

Check the condition and tightening of the screws of terminals F (Fig. 10) and the bolt of shackle G (Fig. 10) once a week.

HOOK

For maximum efficiency keep the hook rotation screw N (Fig. 10) lubricated. Without a load hanging from it, the hook must always rotate freely when pushed slightly by hand P (Fig. 10).. Check the condition and efficiency of safety tab O (Fig. 10).

NL

HARPSLUITING EN KLEMMEN

Het is van belang de staat en de draaiing van de schroeven van de klemmen F (Fig.10) en van de bout van de harpsluiting G (Fig.10) eens in de week na te kijken.

HAAK

Voor een maximale efficiëntie de draaischroef van de haak N (Fig.10) gesmeerd houden.

Zonder hangende lading moet de haak altijd vrij kunnen draaien door er met de hand tegenaan te drukken P (Fig.10).

Controleer de staat en de efficiëntie van de veiligheidssluiting O (Fig.10).

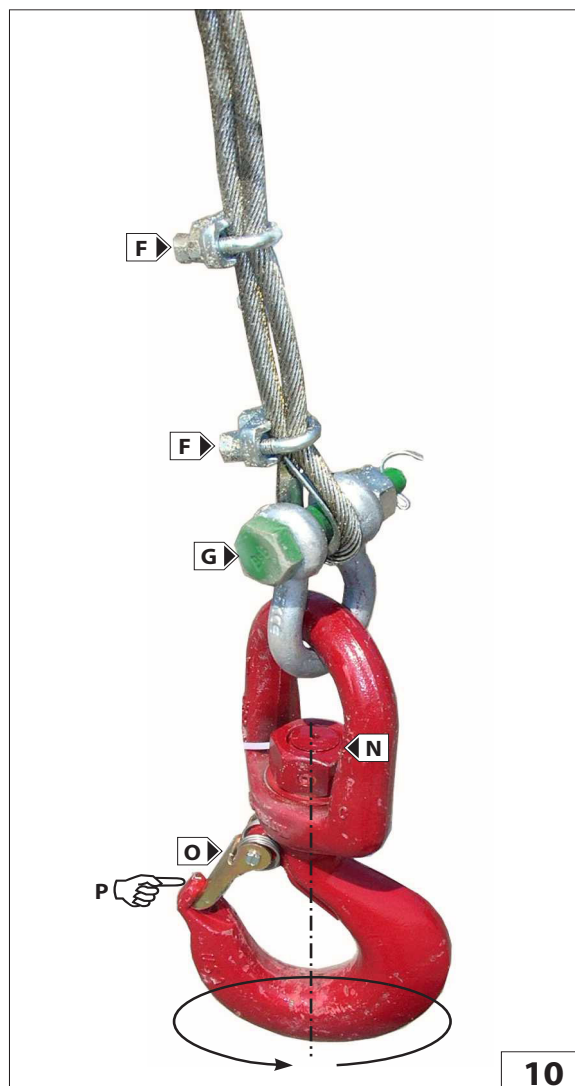

IT

FINE CORSA DISCESA FUNE (Fig.11)

Giornalmente per una massima efficienza mantenere sempre pulito il pistoncino e la valvola idraulica di sicurezza; controllare il serraggio dei raccordi e lo stato dei tubi. Inoltre verificare l'integrità del leveraggio di contatto fincorsa discesa e la tenuta della sua molla.

FINE CORSA SALITA FUNE

Giornalmente per una massima efficienza mantenere sempre pulito il pistoncino e la valvola idraulica di sicurezza; controllare il serraggio dei raccordi e lo stato dei tubi. Inoltre verificare l'integrità del leveraggio di contatto fincorsa salita e la tenuta della sua molla. (Fig.12)

IMPIANTO IDRAULICO (Fig.13)

Ispezionare giornalmente raccordi, valvole, tubi, per evitare eventuali perdite di olio che compromettano il rendimento e la durata dell'argano.

US

ROPE DESCENT LIMIT SWITCH (Fig. 11)

For maximum efficiency, check daily and keep the piston and hydraulic safety valve clean, check to make sure the connections are tightened properly and check the condition of the pipes. Also check the condition of the descent limit switch contact linkages and hold of its spring.

ROPE ASCENT LIMIT SWITCH

For maximum efficiency, check daily and keep the piston and hydraulic safety valve clean, check to make sure the connections are tightened properly and check the condition of the pipes. Also check the condition of the ascent limit switch contact linkages and hold of its spring. (Fig.12)

HYDRAULIC SYSTEM (Fig.13)

Check the connectors, valves, tubes daily to prevent oil leaks which could affect the performance and life of the winch.

NL

EINDAANSLAG KABEL OMLAAG (Fig.11)

Voor een maximale efficiëntie dagelijks altijd het zuigertje en het hydraulische veiligheidsventiel schoon houden; controleer of de verbindingen goed vast zitten en de staat van de leidingen. Controleer eveneens de staat van de hefboomen van de eindaanslag voor het dalen en zijn veer.

EINDAANSLAG KABEL OMHOOG

Voor een maximale efficiëntie dagelijks altijd het zuigertje en het hydraulische veiligheidsventiel schoon houden; controleer of de verbindingen goed vast zitten en de staat van de leidingen. Controleer eveneens de staat van de hefboomen van de eindaanslag voor het stijgen en zijn veer. (Fig.12)

HYDRAULISCHE INSTALLATIE (Fig.13)

Controleer dagelijks de verbindingstukken, kleppen en leidingen om eventuele olielekken te voorkomen die het rendement en de levensduur van de lier zouden kunnen beïnvloeden.

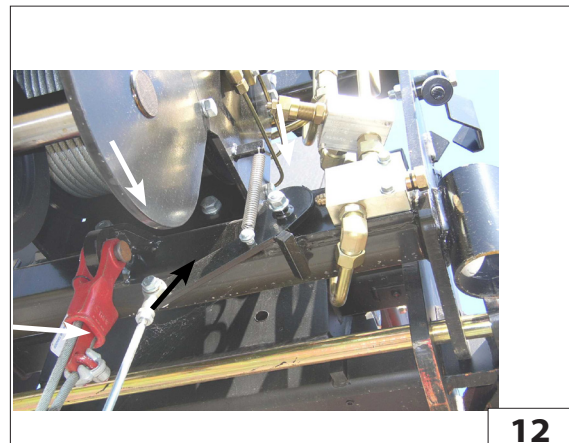
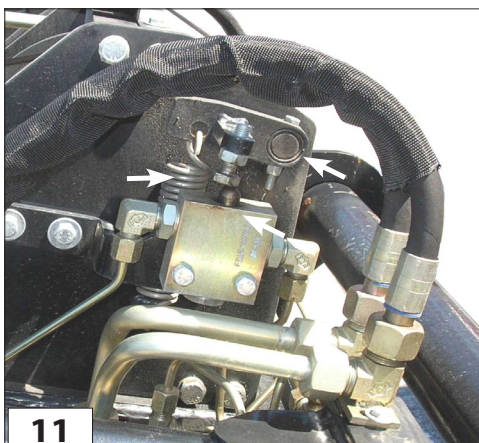
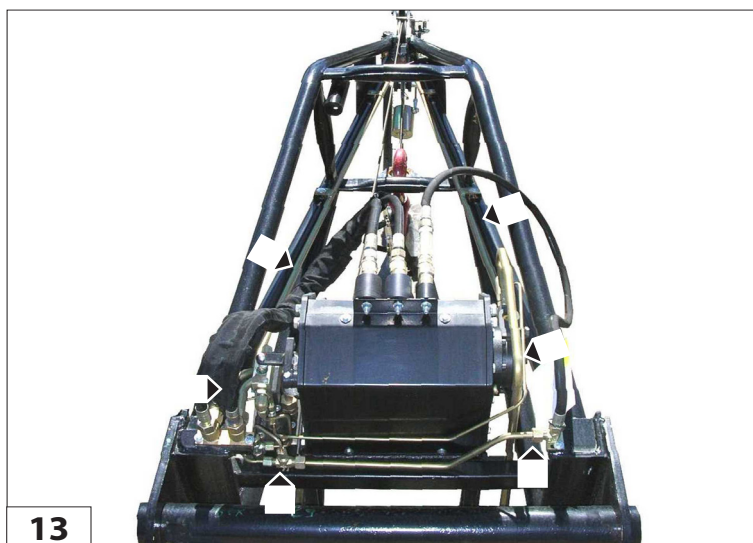

IT

US

NL

SCHEMA IDRAULICO

HYDRAULIC DIAGRAM

HYDRAULISCH SCHEMA

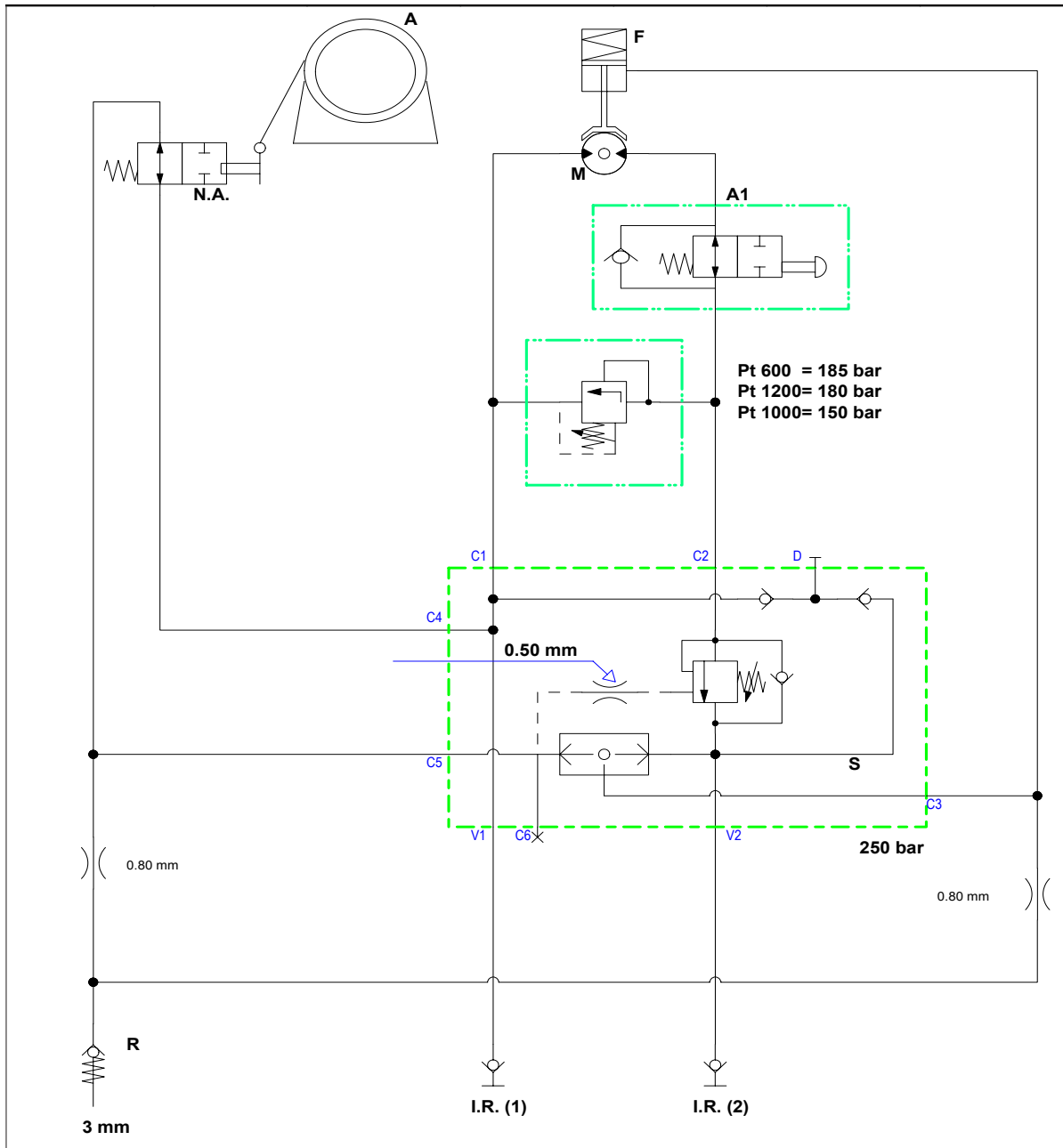

A = ARGANO
N.A. = MICRO MASSIMA DISCESA
R = SERBATOIO OLIO
I.R.1 = INNESTO RAPIDO
I.R.2 = INNESTO RAPIDO
A1 = MICRO MASSIMA SALITA
S = VALVOLA
N = VALVOLA MASSIMA PRESSIONE
M = MOTORE
F = FRENO

A = WINCH
N.A. = MAX. DESCENT MICRO SWITCH
R = OIL TANK
I.R.1 = QUICK-RELEASE COUPLING
I.R.2 = QUICK-RELEASE COUPLING
A1 = MAX. ASCENT MICRO SWITCH
S = VALVE
N = PRESSURE RELIEF VALVE
M = MOTOR
F = BRAKE

A = LIER
N.A. = MICRO MAXIMALE DALING
R = OLJETANK
I.R.1 = SNELKOPPELING
I.R.2 = SNELKOPPELING
A1 = MICRO MAXIMALE STIJGING
S = VENTIEL
N = MAXIMUMDRUKVENTIEL
M = MOTOR
F = REM



Questa pagina è intenzionalmente vuota
This page is left blank intentionally
Deze pagina is opzettelijk leeg gelaten



PT 1000



IT

Descrizione:

Braccetto lungo 4mt con argano portata 1000Kg.

Caratteristiche:

- Tiro al 2° strato di 1000Kg.
- Velocità massima al 2° strato 44mt/min.
- Il tiro è in due taglie.
- La fune è di 56mt, diametro 6mm disposta su due strati.
- Motore orbitale Sauer-Danfoss OMRS80.
- Riduttore epicicloidale con freno negativo a dischi in bagno d'olio.
- Il tamburo è filettato e dotato di un rullo pressa fune in modo da assicurare sempre un corretto avvolgimento della fune.
- Classificazione ISO 4301/1: T4,L2,M4.

Sicurezze:

- Fine corsa discesa idraulico positivo
- Fine corsa salita idraulico positivo

US

Description:

4m long arm with carrying capacity of 1000 kg.

Features:

- Pull at 2nd layer 1000kg.
- Maximum speed at 2nd layer 44 m/min
- The pull is in two sheaves.
- The rope is 56 m long, 6mm diameter arranged in two layers.
- Sauer-Danfoss OMRS80 orbital motor
- Planetary drive with negative oil bath disk brake
- The drum is threaded and provided with a rope press roller in order to always ensure correct winding of the rope.
- ISO 4301/1 Classification: T4, L2, M4.

Safety devices:

- Positive hydraulic descent limit switch
- Positive hydraulic ascent limit switch

NL

Beschrijving:

4 m lange arm met lier met draagvermogen van 1000 kg.

Kenmerken:

- Trekkracht 2de laag 1000 kg.
- Maximumsnelheid 2de laag 44 m/min.
- Kabel dubbel gebruikt.
- De kabel is 56 m, diameter 6 mm in twee lagen.
- Sauer-Danfoss OMRS80 orbitmotor.
- Planetaire reductor met negatieve schijvenrem in oliebad.
- De trommel is gegleufd en voorzien van een kabelaandrukrol voor een altijd correcte opwikkeling van de kabel.
- Classificatie ISO 4301/1: T4,L2,M4.

Beschermingen:

- Positieve hydraulische eindaanslag daling
- Positieve hydraulische eindaanslag stijging





[kg] (lb)	[t]	[mm] (in) x [m] (ft)	[m/min] (ft/min)	[bar] (psi)	[mm] (in)										[kg] (lb)
				P max											
1000 (2204)	5 (5)	∅ 6 (0,2) x 56 (183)	44 (144)	200 (2900)	A	B	C	D	E	F	G	H	I	L	299 (659)
					7290 (287)	4630 (182)	7170 (282)	4510 (177)	2580 (101)	1690 (66)	900 (35)	50 (1,9)	136 (5)	870 (34)	

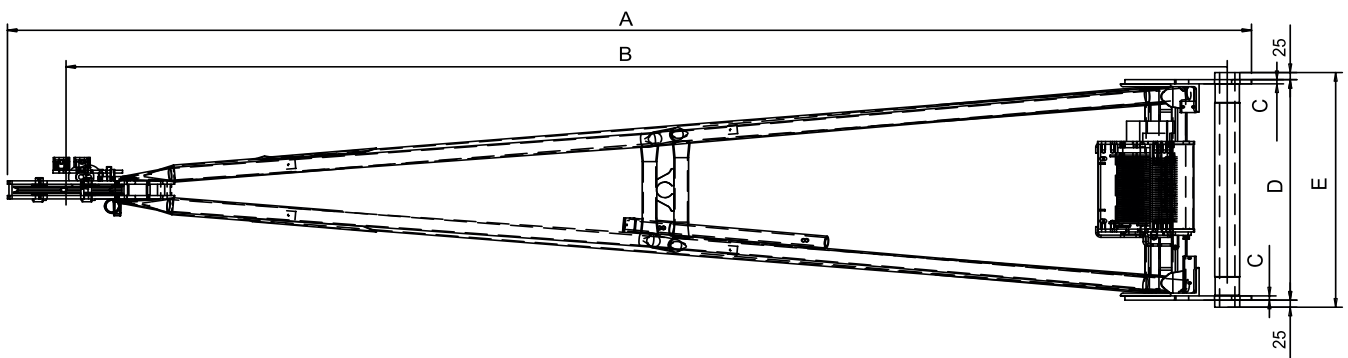
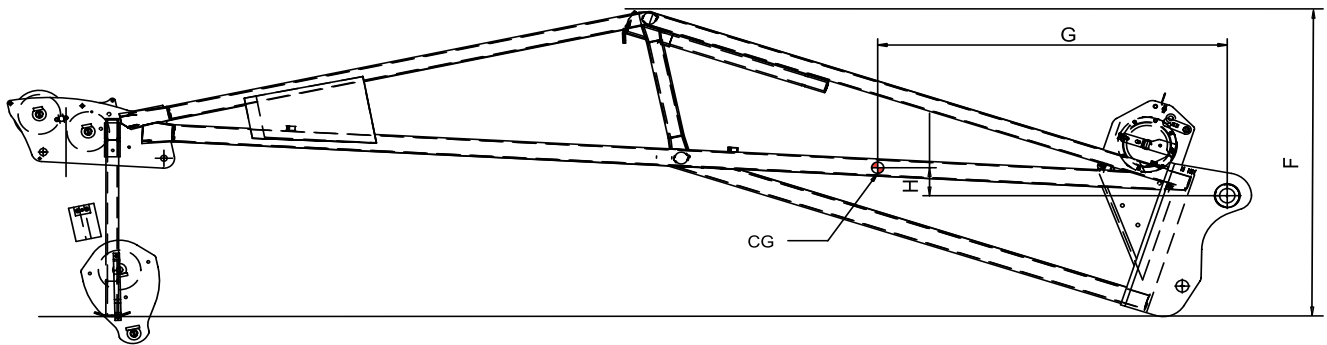

IT

PT 1000

MESSA IN SERVIZIO E UTILIZZO

Per la vostra sicurezza, prima di iniziare un ciclo di lavoro, attenersi alle Istruzioni obbligatorie di verifica e controllo:

- verificare l'integrità della struttura esterna dell'organo e del braccetto tralicciato.
- verificare il corretto collegamento idraulico degli innesti rapidi 1, 2, Drenaggio e lo stato dei tubi flessibili (Fig.1);
- controllare il corretto funzionamento del fine corsa discesa fune L (Fig.2);
- controllare il corretto funzionamento del fine corsa salita fune H (Fig.2);

US

PT 1000

STARTING UP AND USE

For your safety, before starting a work cycle, follow the Compulsory instructions for inspection and control:

- check to make sure the external structure of the winch and latticed boom is intact.
- Check to ensure the correct hydraulic connection of quick-release couplings 1, 2, drainage and the condition of the hose pipes (Fig.1);
- check to ensure correct working of the rope ascent limit switch L (Fig.2);
- check to ensure correct working of the rope descent limit switch H (Fig.2);

NL

PT 1000

INBEDRIJFSTELLING EN GEBRUIK

Houd u, voor uw eigen veiligheid, voor met een werkcyclus aan te vangen, aan de verplichte controle-instructies:

- controleer of de buitenste structuur van de lier en van de vakwerkarm intact is.
- controleer of de hydraulische verbinding van de snelkoppelingen 1, 2, Afvoer en de staat van de slangen in orde zijn (Fig.1);
- controleer de werking van de eindaanslag kabel omlaag L (Fig.2);
- controleer de werking van de eindaanslag kabel omhoog H (Fig.2);

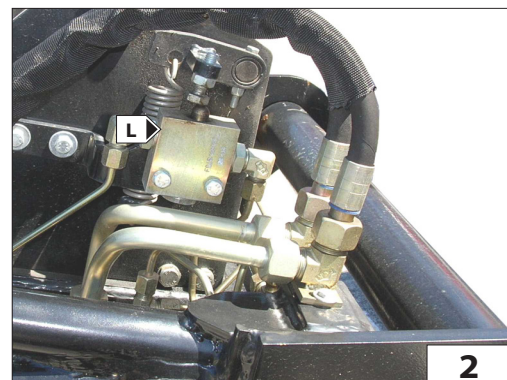
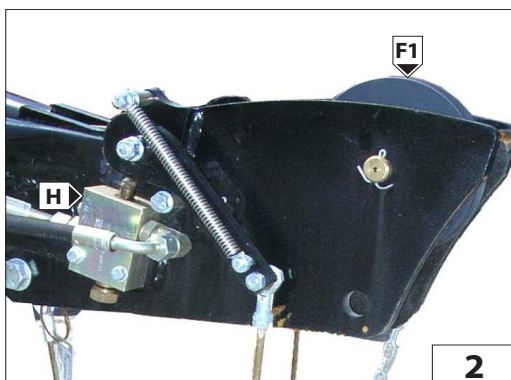
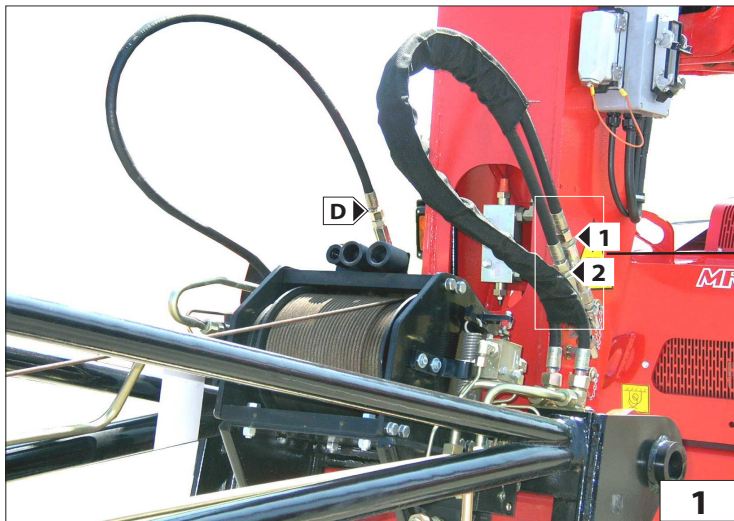

IT

- controllare lo stato della fune B (Fig.3) e il corretto avvolgimento sul tamburo A (Fig.3);
- controllare il corretto movimento rotazione delle pulegge di guida fune F1 (Fig.2 e 4);
- controllare lo stato del capocorda C (Fig.3);
- verificare l'integrità del bozzello F (Fig.4)
- verificare lo stato del gancio K (Fig.4): che non sia deformato, che ruoti liberamente e che la linguetta di sicurezza sia efficiente K1 (Fig.4);
- controllare l'aggancio del braccetto alla macchina operatrice J (Fig.5).

Dalla posizione di parcheggio è possibile sganciare il piede di appoggio e posizionarlo all'interno del braccetto per operare senza ulteriori ingombri J1 (Fig.5).

US

- check the condition of the rope B (Fig. 3) and that it is wound correctly on the drum A (Fig.3);
- check to ensure correct rotation movement of the rope guide pulley F1 (Fig. 2 and 4);
- check the condition of cable terminal C (Fig. 3);
- check the integrity of the block F (Fig.4)
- check the condition of the hook K (Fig. 4): to make sure it is not deformed, that it rotates freely and that the safety tab K1 (Fig. 4) is in working order;
- check the hook-up of the boom to the operating machine J (Fig. 5).

From the parking position it is possible to unhook the foot and position it inside the boom to operate without increasing the dimensions J1 (Fig.5).

NL

- controleer de staat van de kabel B (Fig.3) en de opwikkeling op de trommel A (Fig.3);
- controleer de draaibeweging van de kabelgeleidewielen F1 (Fig.2 en 4);
- controleer de staat van het kabeluiteinde C (Fig.3);
- controleer de staat van de takel F (Fig.4);
- controleer de staat van de haak K (Fig.4): of deze niet vervormd is, of hij vrij draait en of zijn veiligheidsluiting efficiënt is K1 (Fig.4);
- controleer de aankoppeling van de arm aan de machine J (Fig.5).

Vanuit de parkeerstand kan de steunpoot losgemaakt worden en binnenin de arm geplaatst worden om zonder onnodige ruimte innemende structuren te kunnen werken J1 (Fig.5).

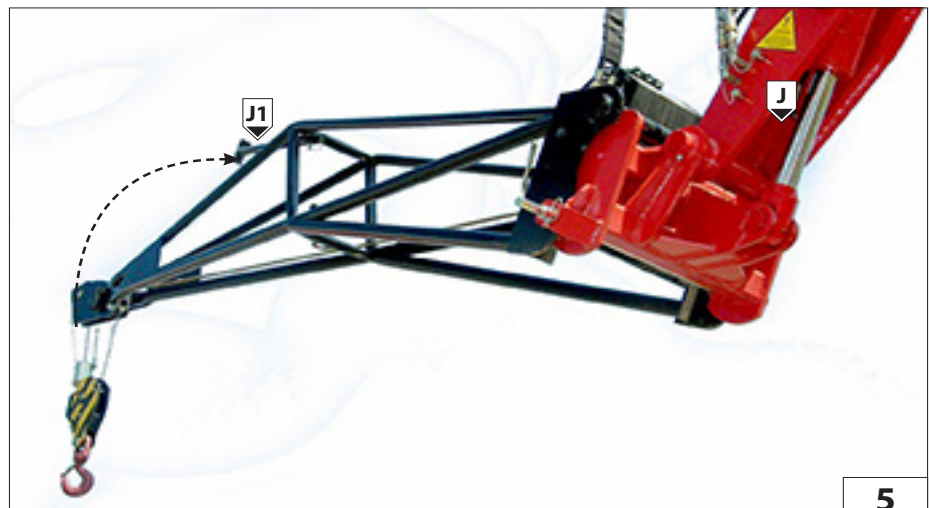
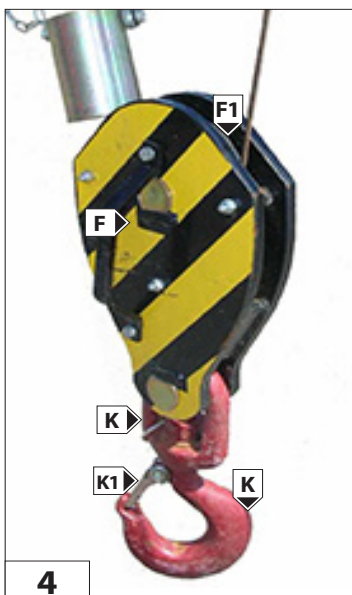
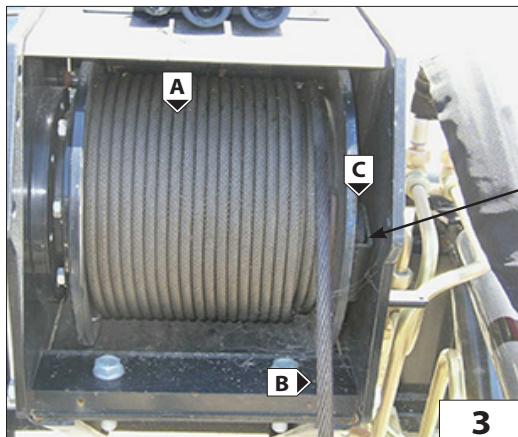



IT

MANUTENZIONE

- RIDUTTORE
- FUNE, PULEGGIA E CAPOCORDA
- BOZZELLO
- GANCIO
- FINE CORSA DISCESA FUNE
- FINE CORSA SALITA FUNE
- IMPIANTO IDRAULICO

US

MAINTENANCE

- REDUCTION GEAR
- ROPE, PULLEY AND CABLE TERMINAL
- PULLEY BLOCK
- HOOK
- ROPE DESCENT LIMIT SWITCH
- ROPE ASCENT LIMIT SWITCH
- HYDRAULIC SYSTEM

NL

ONDERHOUD

- REDUCTOR
- KABEL, KABELSCHIJF en KABELUI-
TEINDEN
- TAKEL
- HAAK
- EINDAANSLAG KABEL OMLAAG
- EINDAANSLAG KABEL OMHOOG
- HYDRAULISCH CIRCUIT

IT

RIDUTTORE

Una corretta lubrificazione consente un buon funzionamento e una lunga durata del riduttore.

Per accedere all'indicatore di livello o al tappo di rabbocco olio, occorre srotolare completamente la fune dal tamburo.

Controllare il livello dell'olio ogni 100 ore A (Fig.6b) e all'occorrenza rabboccare A (Fig.6b) con olio dello stesso tipo di quello presente all'interno del riduttore (SHELL SPIRAX HD80 W90).

Si consiglia l'utilizzo di olio per ingranaggi con additivazione EP con viscosità SAE 80W/90 oppure SAE 85W/140.

La prima sostituzione dell'olio deve essere effettuata dopo 150 ore di funzionamento, successivamente ogni 1000 ore di funzionamento.

Eseguire il cambio dell'olio con riduttore ancora caldo per facilitare un completo svuotamento.

Per scaricare l'olio, ruotare il tamburo del motore portando il tappo di rabbocco / scarico A (Fig.6a) verso il basso. Svitare il tappo A (Fig.6a) e scaricare completamente l'olio.

Ruotare il tamburo portando il foro di rabbocco/scarico sull'asse orizzontale A (Fig.6b).

Rabboccare con olio nuovo e di tipo corretto fino a quando l'olio non fuoriesce da foro di livello A (Fig.6b). (0,6 lt)

Riavvitare i tappi e riavvolgere la fune.

US

REDUCTION GEAR

Correct lubrication allows proper working and longer life of the reduction gear.

To access the level indicator or oil topping up cap, the rope must be unwound completely from the drum.

Check the oil level at least every 100 hours A (Fig.6b) and if required, top up A (Fig.6b) with oil of the same type as that present inside the reduction gear (SHELL SPIRAX HD80 W90).

Use gear oil with additive EP with viscosity SAE 80W/90 or SAE 85W/140.

The first oil change must be after 150 hours of operation, then subsequently every 1000 hours of operation.

Change the oil with the reduction gear still hot to allow complete drainage.

To drain the oil, turn the engine drum so that the filler/drainage cap A (Fig. 6a) is facing downwards.

Unscrew cap A (Fig.6a) and drain out the oil completely.

Turn the drum to bring the topping up/drainage hole horizontal A (Fig.6b).

Top up with fresh oil of the correct type until the oil flows out through the level hole A (Fig.6b). (0.6 l).

Screw the cap back on and rewind the rope.

NL

REDUCTOR

Een correcte smering maakt een goede werking en een lange levensduur van de reductor mogelijk.

Om toegang te verkrijgen tot de oliepeilindicator of de oliebijkvuldop, moet de kabel helemaal van de trommel gerold worden.

Controleer het oliepeil om de 100 uren A (Fig.6b) en indien nodig bijvullen A (Fig.6b) met olie van hetzelfde soort als dat aanwezig is in de reductor (SHELL SPIRAX HD80 W90).

Er wordt aangeraden olie voor tandwielen te gebruiken met additievering van EP met viscositeit SAE 80W/90 of SAE 85W/140.

De eerste olieversing moet na 150 werkuren plaatsvinden, daarna om de 1000 werkuren.

Ververs de olie met nog warme reductor om een complete leging te vergemakkelijken.

Om de olie af te voeren, de trommel van de motor zodanig draaien dat de bijvul/aftapdop A (Fig.6a) naar beneden staat.

Draai de dop A (Fig.6a) los en laat alle olie weglopen.

Draai de trommel zodanig dat de bijvul-/aftapopening op de horizontale as staat A (Fig.6b).

Vul bij met nieuwe olie van het juiste type totdat de olie door de oliepeilopening naar buiten komt A (Fig.6b). (0,6 l)

Draai de doppen weer vast en wikkel de kabel weer op.

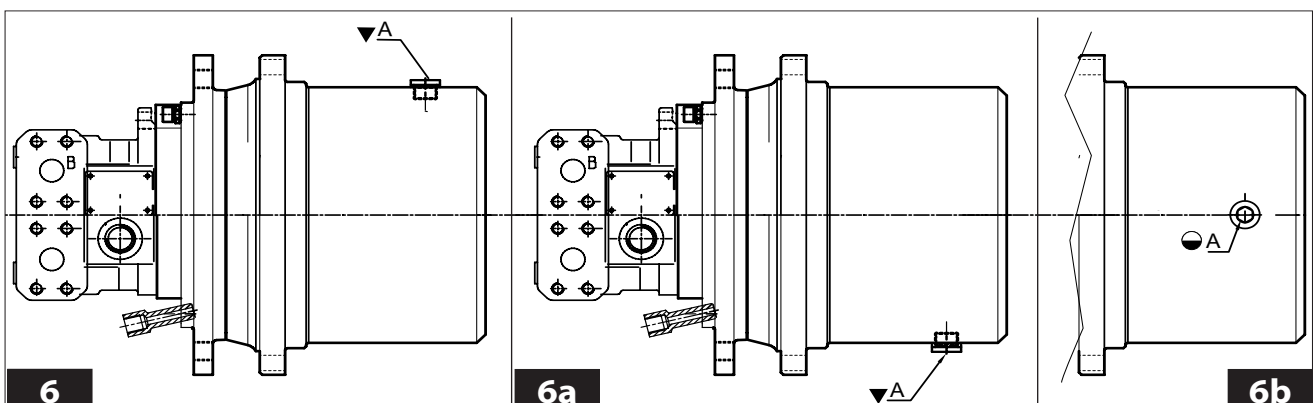
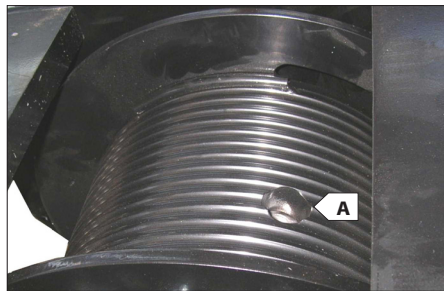

IT

FUNE, PULEGGIA e CAPOCORDA

Controllare giornalmente che la fune A (Fig.7) sia sempre in ottimo stato, che non ci siano filamenti rotti (Fig.7a) e che sia ben arrotolata sul tamburo B (Fig.7).

Altrimenti sostituirla con una nuova e dello stesso diametro e caratteristiche. Controllare la lubrificazione della fune, se necessita lubrificare con grasso industriale oppure olio sintetico anti-polvere.

Controllare e mantenere lubrificato i perni C (Fig.8) su cui ruotano le puleggie di guida D (Fig.8), che dovranno avere sempre un buono movimento di rotazione. Se necessita, lubrificare con grasso al sapone di litio il perno.

Assicurarsi dell'integrità dei capocorda E (Fig.9) e dei suoi morsetti fermafune.

US

ROPE, PULLEY AND CABLE TERMINAL

Check daily to make sure the rope A (Fig.7) is always in excellent condition, that it is not frayed (Fig.7a) and that it is wound perfectly around the drum B (Fig.7).

If necessary replace with a new rope having the same diameter and features. Check the lubrication of the rope, if necessary, lubricate with industrial grease or dust-proof synthetic oil.

Check and lubricate the pins C (Fig. 8) on which the guide pulleys D (Fig. 8) rotate and these must always rotate perfectly. If necessary, lubricate the pin with lithium soap grease.

Ensure the integrity of the cable terminals E (Fig.9) and the rope retainer clamps.

NL

KABEL, KABELSCHIJF en KABELUIT-EINDEN

Controleer dagelijks of de kabel A (Fig.7) in optimale staat verkeert, of er geen draden stuk zijn (Fig.7a) en of hij goed op de trommel gewonden is B (Fig.7).

Vervang hem anders door een nieuwe met dezelfde diameter en eigenschappen.

Controleer de smering van de kabel, indien nodig smeren met industrieel vet of synthetische olie tegen stof.

Controleer de pennen C (Fig.8) waarop de geleideschijven D (Fig.8) draaien en houd ze gesmeerd. Deze moet altijd een goede draaibeweging behouden. Indien nodig, de pen invetten met lithiumzeepvet.

Controleer de staat van de kabeluiteinden E (Fig.9) en de kabelklemmen.

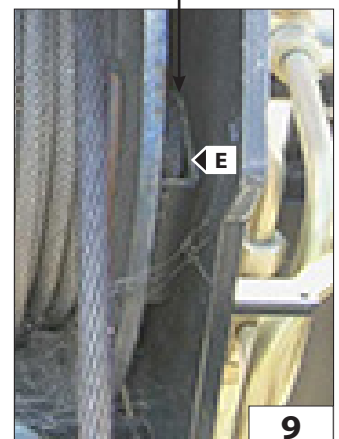
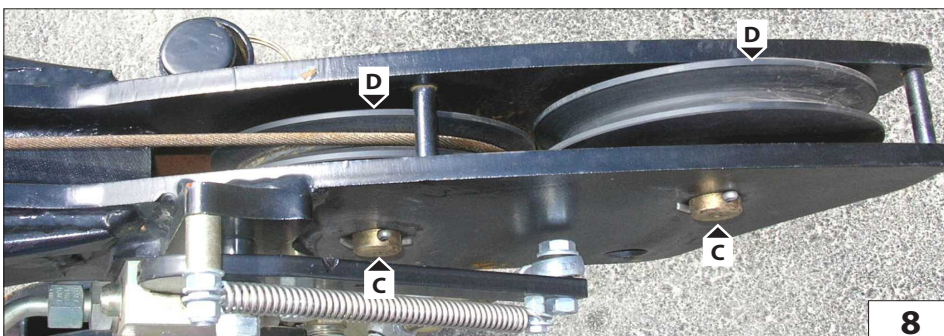
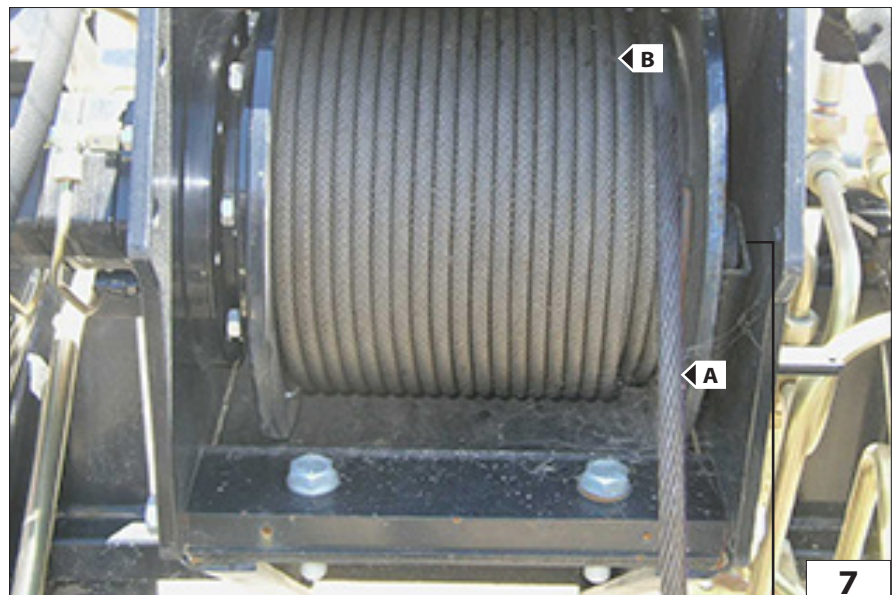
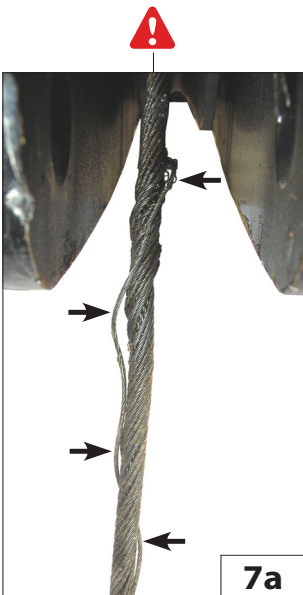

IT

BOZZELLO

Per una massima efficienza e sicurezza, mantenere intatta la struttura esterna F (Fig.10) e controllare che la puleggia G (Fig.10) ruoti correttamente sul suo perno G1 (Fig.10) .
Se necessità, lubrificare con grasso al sapone di litio il perno G1 (Fig.10).

GANCIO

Per una massima efficienza mantenere lubrificata la vite di rotazione del gancio N (Fig.10).
Senza carico sospeso, il gancio deve sempre ruotare liberamente e con la sola pressione della mano P (Fig.10).
Controllare lo stato e l'efficienza della linguetta di sicurezza O (Fig.10).

US

PULLEY BLOCK

For maximum efficiency and safety, keep the external structure F (Fig.10) intact and check to make sure the pulley G (Fig.10) rotates correctly on its pin G1 (Fig.10) .
If necessary, lubricate the pin G1 (Fig. 10) with lithium soap grease.

HOOK

For maximum efficiency keep the hook rotation screw N (Fig. 10) lubricated.
Without a load hanging from it, the hook must always rotate freely when pushed slightly by hand P (Fig. 10)..
Check the condition and efficiency of safety tab O (Fig. 10).

NL

TAKEL

Voor een maximale efficiëntie en veiligheid, houd de buitenste structuur intact F (Fig.10) en controleer of de kabelschijf G (Fig.10) goed op zijn pen draait G1 (Fig.10).
Indien nodig, de pen G1 (Fig.10) invetten met lithiumzeepvet.

HAAK

Voor een maximale efficiëntie de draaischroef van de haak N (Fig.10) gesmeerd houden.
Zonder hangende lading moet de haak altijd vrij kunnen draaien door er met de hand tegenaan te drukken P (Fig.10).
Controleer de staat en de efficiëntie van de veiligheidssluiting O (Fig.10).

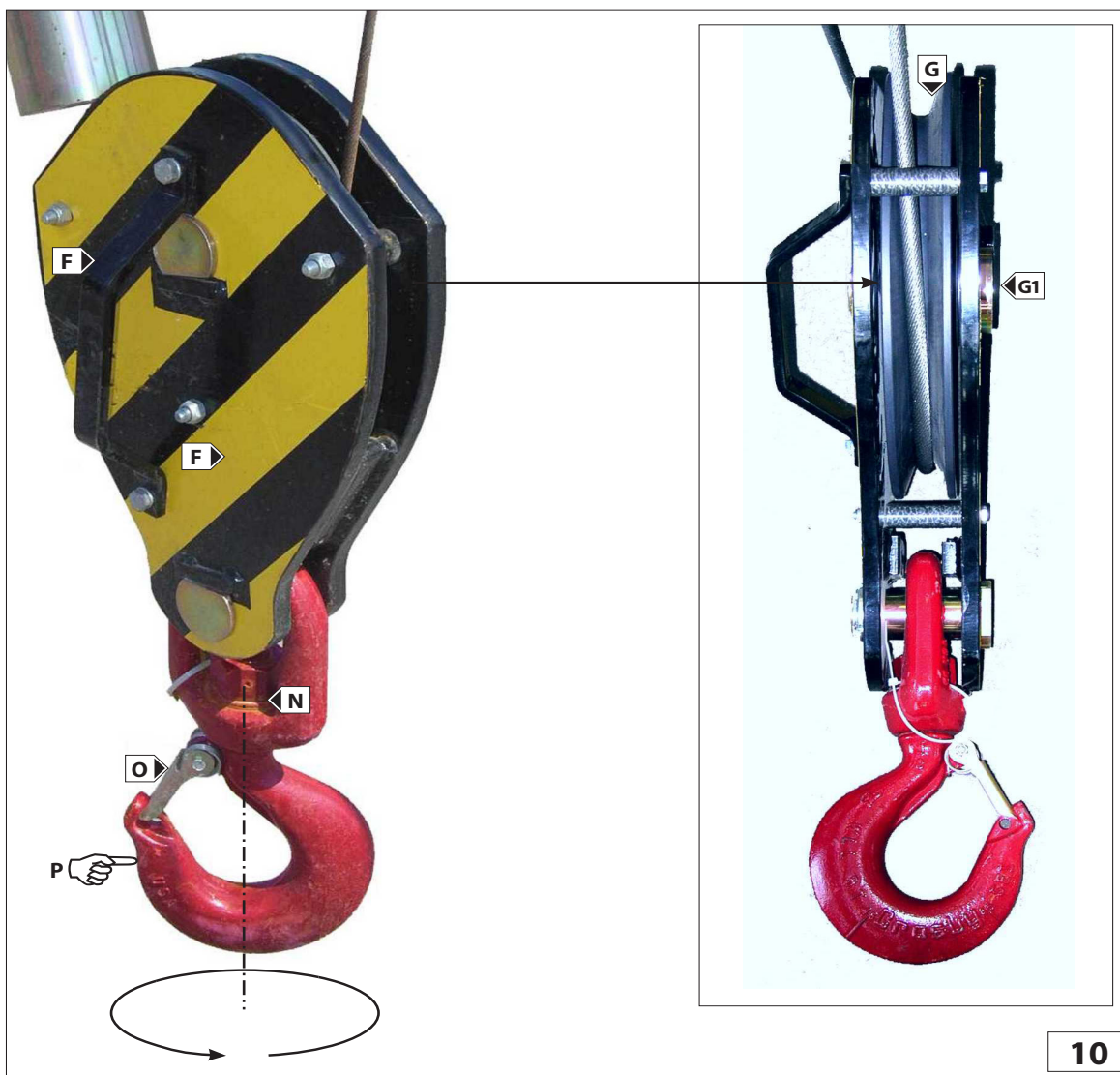

IT

FINE CORSA DISCESA FUNE (Fig.11)

Giornalmente per una massima efficienza mantenere sempre pulito il pistoncino e la valvola idraulica di sicurezza; controllare il serraggio dei raccordi e lo stato dei tubi. Inoltre verificare l'integrità del leveraggio di contatto finecorsa discesa e la tenuta della sua molla.

FINE CORSA SALITA FUNE

Giornalmente per una massima efficienza mantenere sempre pulito il pistoncino e la valvola idraulica di sicurezza; controllare il serraggio dei raccordi e lo stato dei tubi. Inoltre verificare l'integrità del leveraggio di contatto finecorsa salita e la tenuta della sua molla. (Fig.12)

IMPIANTO IDRAULICO (Fig.13)

Ispezionare giornalmente raccordi, valvole, tubi, per evitare eventuali perdite di olio che compromettano il rendimento e la durata dell'argano.

US

ROPE DESCENT LIMIT SWITCH (Fig. 11)

For maximum efficiency, check daily and keep the piston and hydraulic safety valve clean, check to make sure the connections are tightened properly and check the condition of the pipes. Also check the condition of the descent limit switch contact linkages and hold of its spring.

ROPE ASCENT LIMIT SWITCH

For maximum efficiency, check daily and keep the piston and hydraulic safety valve clean, check to make sure the connections are tightened properly and check the condition of the pipes. Also check the condition of the ascent limit switch contact linkages and hold of its spring. (Fig.12)

HYDRAULIC SYSTEM (Fig.13)

Check the connectors, valves, tubes daily to prevent oil leaks which could affect the performance and life of the winch.

NL

EINDAANSLAG KABEL OMLAAG (Fig.11)

Voor een maximale efficiëntie dagelijks altijd het zuigertje en het hydraulische veiligheidsventiel schoon houden; controleer of de verbindingen goed vast zitten en de staat van de leidingen. Controleer eveneens de staat van de hefbomen van de eindaanslag voor het dalen en zijn veer.

EINDAANSLAG KABEL OMHOOG

Voor een maximale efficiëntie dagelijks altijd het zuigertje en het hydraulische veiligheidsventiel schoon houden; controleer of de verbindingen goed vast zitten en de staat van de leidingen. Controleer eveneens de staat van de hefbomen van de eindaanslag voor het stijgen en zijn veer. (Fig.12)

HYDRAULISCHE INSTALLATIE (Fig.13)

Controleer dagelijks de verbindingstukken, kleppen en leidingen om eventuele olielekken te voorkomen die het rendement en de levensduur van de lier zouden kunnen beïnvloeden.

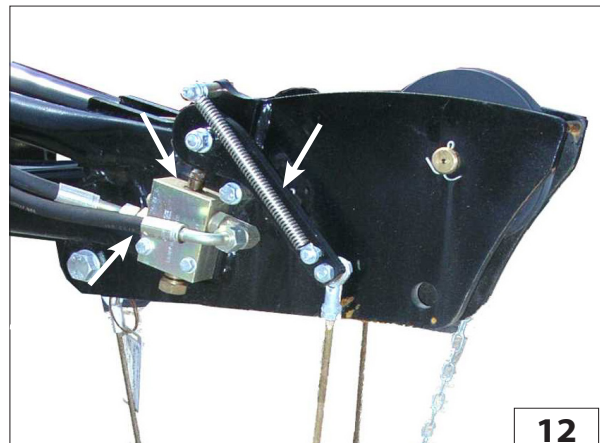
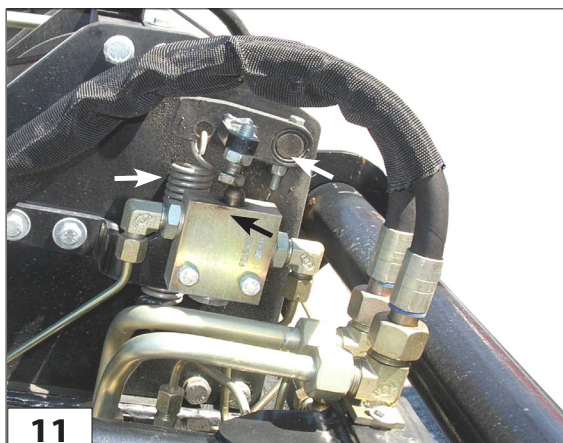
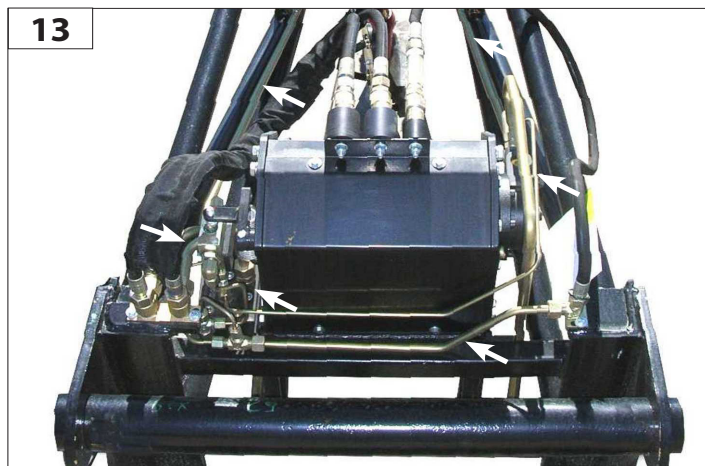

IT

US

NL

SCHEMA IDRAULICO

HYDRAULIC DIAGRAM

HYDRAULISCH SCHEMA

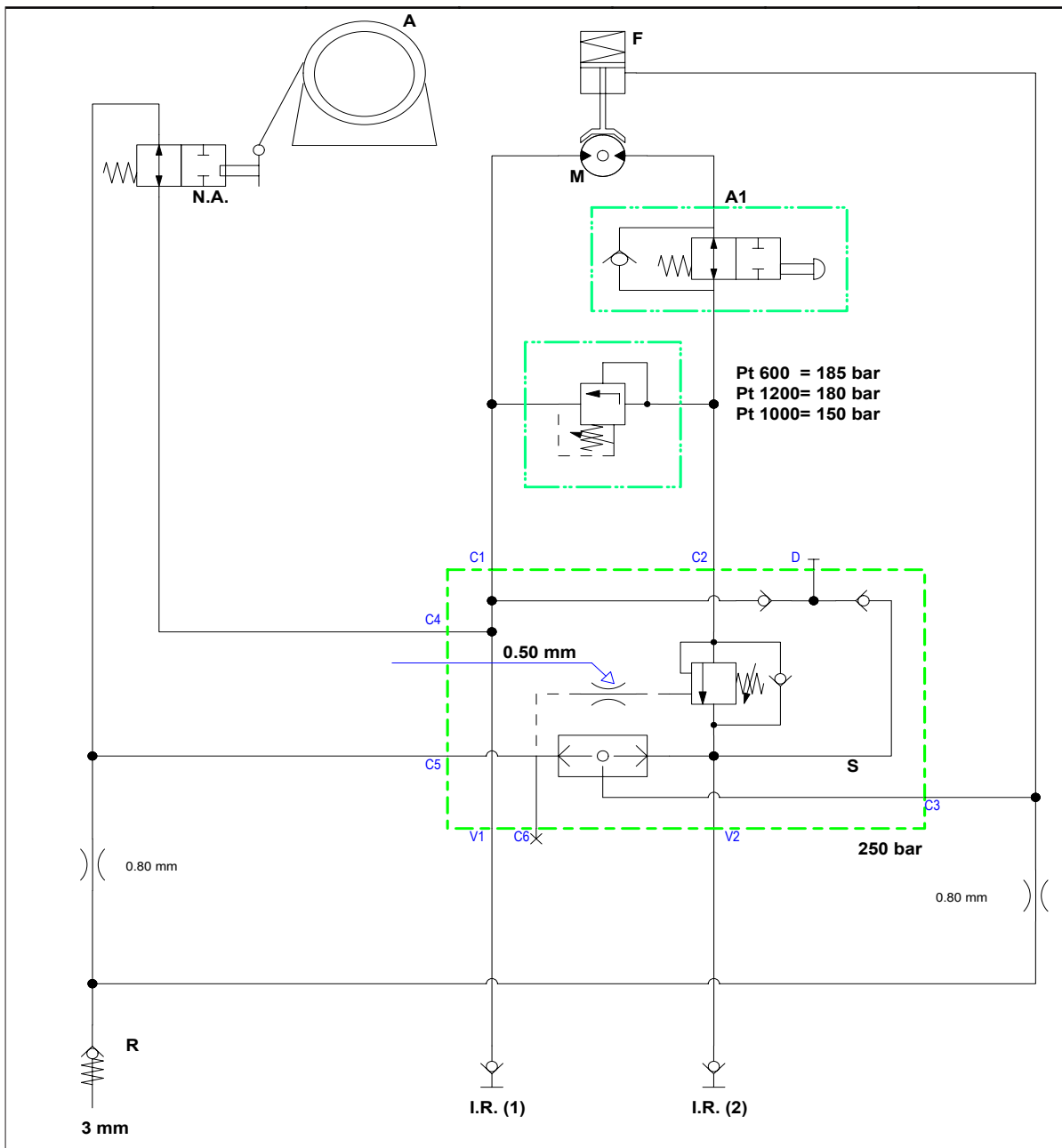

A = ARGANO
N.A. = MICRO MASSIMA DISCESA
R = SERBATOIO OLIO
I.R.1 = INNESTO RAPIDO
I.R.2 = INNESTO RAPIDO
A1 = MICRO MASSIMA SALITA
S = VALVOLA
N = VALVOLA MASSIMA PRESSIONE
M = MOTORE
F = FRENO

A = WINCH
N.A. = MAX. DESCENT MICRO SWITCH
R = OIL TANK
I.R.1 = QUICK-RELEASE COUPLING
I.R.2 = QUICK-RELEASE COUPLING
A1 = MAX. ASCENT MICRO SWITCH
S = VALVE
N = PRESSURE RELIEF VALVE
M = MOTOR
F = BRAKE

A = LIER
N.A. = MICRO MAXIMALE DALING DISCESA
R = OLIE TANK
I.R.1 = SNELKOPPELING
I.R.2 = SNELKOPPELING
A1 = MICRO MAXIMALE STIJGING SALITA
S = VENTIEL
N = MAXIMUMDRUKVENTIEL
M = MOTOR
F = REM



Questa pagina è intenzionalmente vuota
This page is left blank intentionally
Deze pagina is opzettelijk leeg gelaten



PT 1200

IT

Descrizione:

Braccetto lungo 3mt con argano portata 1200Kg.

Caratteristiche:

- Tiro al 2° strato di 1200Kg.
- Velocità massima al 2° strato 44mt/min.
- Il tiro è in due taglie.
- La fune è di 46mt, diametro 6mm disposta su due strati.
- Motore orbitale Sauer-Danfoss OMRS80.
- Riduttore epicicloidale con freno negativo a dischi in bagno d'olio.
- Il tamburo è filettato e dotato di un rullo pressa fune in modo da assicurare sempre un corretto avvolgimento della fune.
- Classificazione ISO 4301/1: T4,L2,M4.

Sicurezze:

- Fine corsa discesa idraulico positivo.
- Fine corsa salita idraulico positivo.

US

Description:

3m long arm with carrying capacity of 1200 kg.

Features:

- Pull at 2nd layer 1200kg.
- Maximum speed at 2nd layer 44 m/min
- The pull is in two sheaves.
- The rope is 46 m long, 6mm diameter arranged in two layers.
- Sauer-Danfoss OMRS80 orbital motor
- Planetary drive with negative oil bath disk brake
- The drum is threaded and provided with a rope press roller in order to always ensure correct winding of the rope.
- ISO 4301/1 Classification: T4, L2, M4.

Safety devices:

- Positive hydraulic descent limit switch.
- Positive hydraulic ascent limit switch.

NL

Beschrijving:

3 m lange arm met lier met draagvermogen van 1200 kg.

Kenmerken:

- Trekkracht 2de laag 1200 kg.
- Maximumsnelheid 2de laag 44 m/min.
- Kabel dubbel gebruikt.
- De kabel is 46 m, diameter 6 mm in twee lagen.
- Sauer-Danfoss OMRS80 orbitmotor.
- Planetaire reductor met negatieve schijvenrem in oliebad.
- De trommel is gegleufd en voorzien van een kabelandrukrol voor een altijd correcte opwikkeling van de kabel.
- Classificatie ISO 4301/1: T4,L2,M4.

Beschermingen:

- Positieve hydraulische eindaanslag daling.
- Positieve hydraulische eindaanslag stijging.

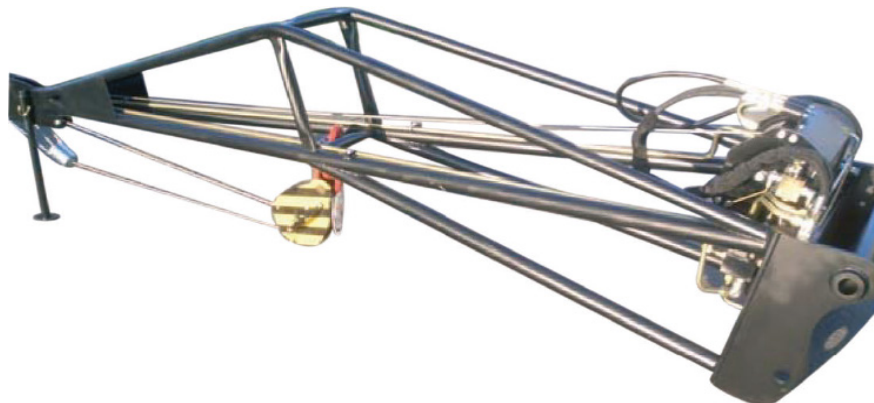



[kg] (lb)	[t] (t)	[mm] (in) x [m] (ft)	[m/min] (ft/min)	[bar] (psi)	[mm] (in)						[kg] (lb)
				P max							
1200 (2204)	5 (5)	∅ 6 (0,2) x 46 (150)	44 (144)	200 (2900)	A 750 (29)	B 41 (1,6)	C 942 (37)	D 2680 (105)	E 2934 (115)	F 671 (26)	360 (793)

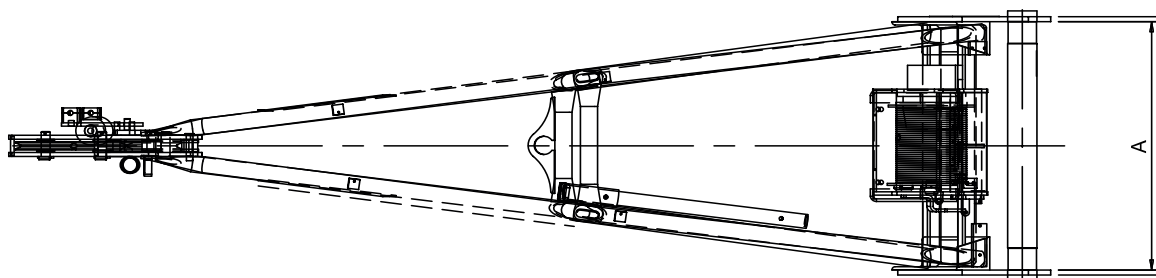
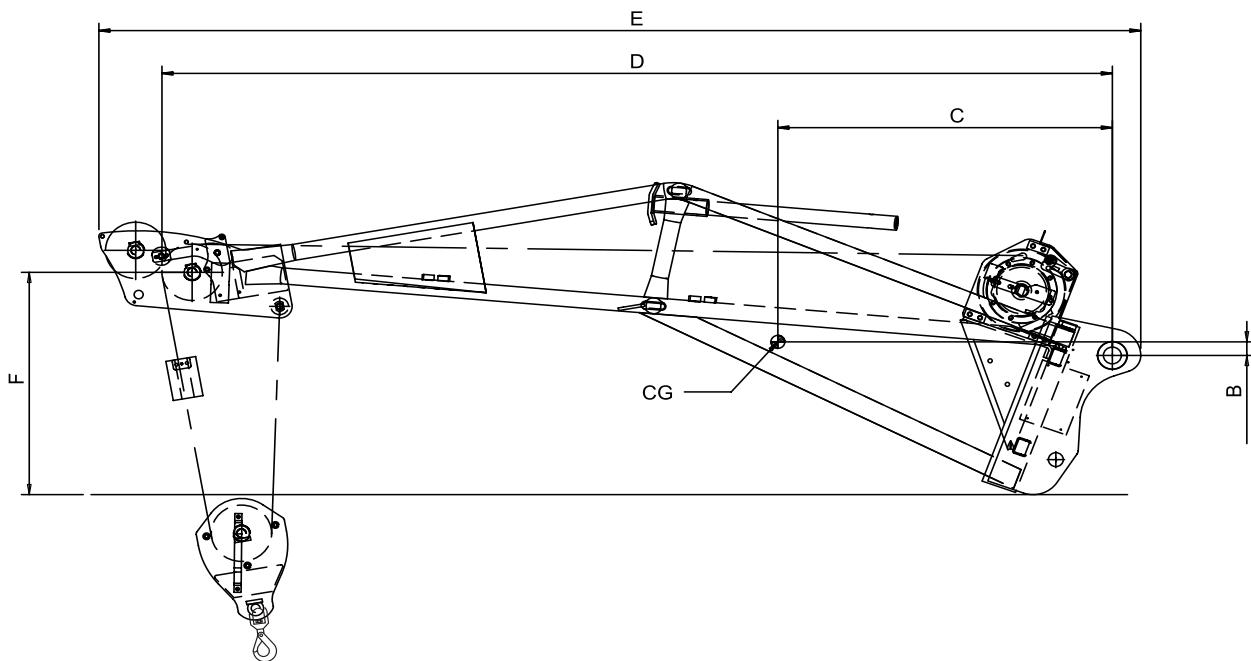

IT

PT 1200

MESSA IN SERVIZIO E UTILIZZO

Per la vostra sicurezza, prima di iniziare un ciclo di lavoro, attenersi alle Istruzioni obbligatorie di verifica e controllo:

- verificare l'integrità della struttura esterna dell'argano e del braccetto tralicciato.
- verificare il corretto collegamento idraulico degli innesti rapidi 1, 2, Drenaggio e lo stato dei tubi flessibili (Fig.1);
- controllare il corretto funzionamento del fine corsa discesa fune L (Fig.2);
- controllare il corretto funzionamento del fine corsa salita fune H (Fig.2);

US

PT 1200

STARTING UP AND USE

For your safety, before starting a work cycle, follow the Compulsory instructions for inspection and control:

- check to make sure the external structure of the winch and latticed boom is intact.
- Check to ensure the correct hydraulic connection of quick-release couplings 1, 2, drainage and the condition of the hose pipes (Fig.1);
- check to ensure correct working of the rope ascent limit switch L (Fig.2);
- check to ensure correct working of the rope descent limit switch H (Fig.2);

NL

PT 1200

INBEDRIJFSTELLING EN GEBRUIK

Houd u, voor uw eigen veiligheid, voor met een werkcyclus aan te vangen, aan de verplichte controle-instructies:

- controleer of de buitenste structuur van de lier en van de vakwerkarm intact is.
- controleer of de hydraulische verbinding van de snelkoppelingen 1, 2, Afvoer en de staat van de slangen in orde zijn (Fig.1);
- controleer de werking van de eindaanslag kabel omlaag L (Fig.2);
- controleer de werking van de eindaanslag kabel omhoog H (Fig.2);

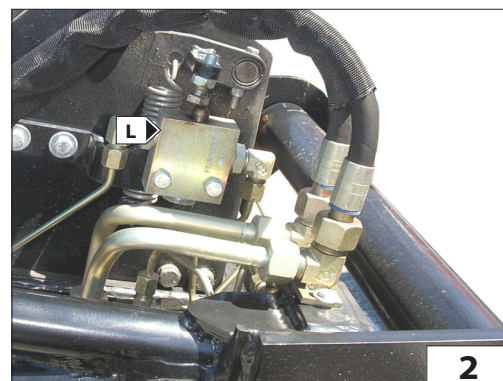
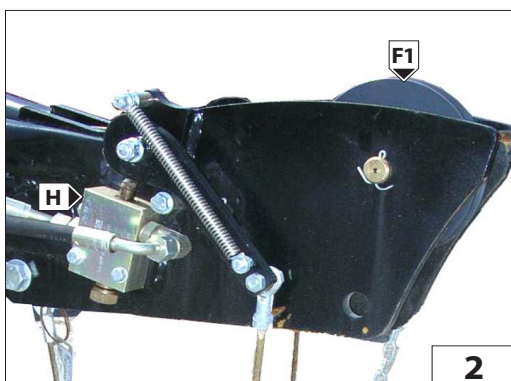
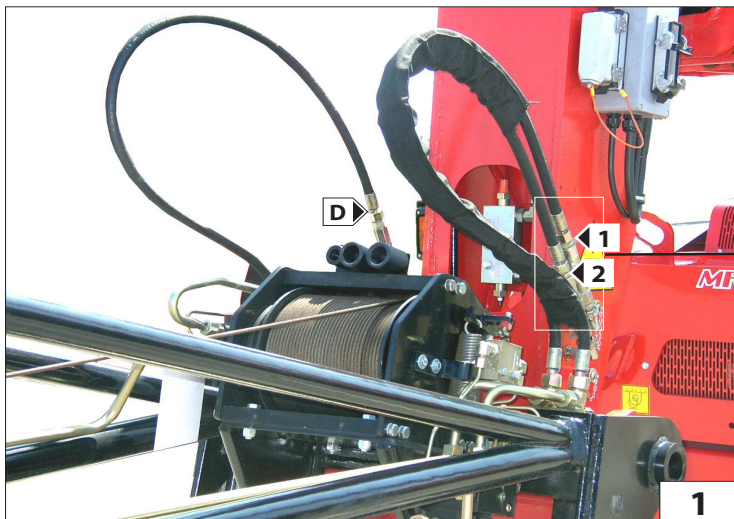

IT

- controllare lo stato della fune B (Fig.3) e il corretto avvolgimento sul tamburo A (Fig.3);
- controllare il corretto movimento rotazione delle pulegge di guida fune F1 (Fig.2 e 4);
- controllare lo stato del capocorda C (Fig.3);
- verificare l'integrità del bozzello F (Fig.4)
- verificare lo stato del gancio K (Fig.4): che non sia deformato, che ruoti liberamente e che la linguetta di sicurezza sia efficiente K1 (Fig.4);
- controllare l'aggancio del braccetto alla macchina operatrice J (Fig.5).

US

- check the condition of the rope B (Fig. 3) and that it is wound correctly on the drum A (Fig.3);
- check to ensure correct rotation movement of the rope guide pulley F1 (Fig. 2 and 4);
- check the condition of cable terminal C (Fig. 3);
- check the integrity of the block F (Fig.4)
- check the condition of the hook K (Fig. 4): to make sure it is not deformed, that it rotates freely and that the safety tab K1 (Fig. 4) is in working order;
- check the hook-up of the boom to the operating machine J (Fig. 5).

NL

- controleer de staat van de kabel B (Fig.3) en de opwikkeling op de trommel A (Fig.3);
- controleer de draaibeweging van de kabelgeleidewielen F1 (Fig.2 en 4);
- controleer de staat van het kabeluiteinde C (Fig.3);
- controleer de staat van de takel F (Fig.4);
- controleer de staat van de haak K (Fig.4): of deze niet vervormd is, of hij vrij draait en of zijn veiligheidssluiting efficiënt is K1 (Fig.4);
- controleer de aankoppeling van de arm aan de machine J (Fig.5).

Dalla posizione di parcheggio è possibile sganciare il piede di appoggio e posizionarlo all'interno del braccetto per operare senza ulteriori ingombri J1 (Fig.5).

From the parking position it is possible to unhook the foot and position it inside the boom to operate without increasing the dimensions J1 (Fig.5).

Vanuit de parkeerstand kan de steunpoot losgemaakt worden en binnenin de arm geplaatst worden om zonder onnodige ruimte innemende structuren te kunnen werken J1 (Fig.5).

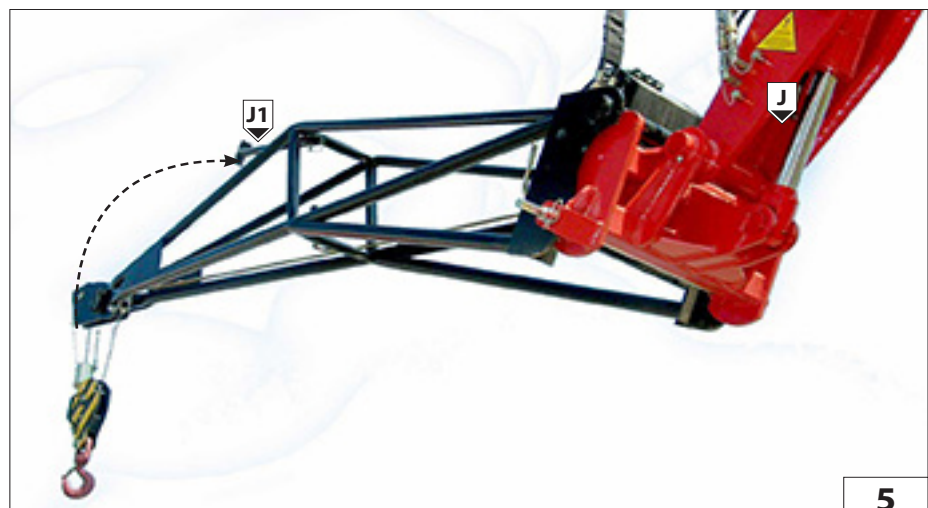
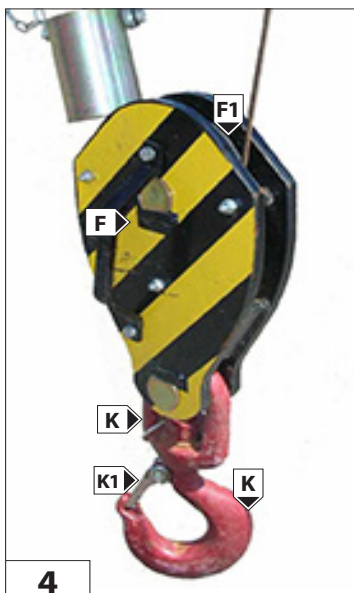
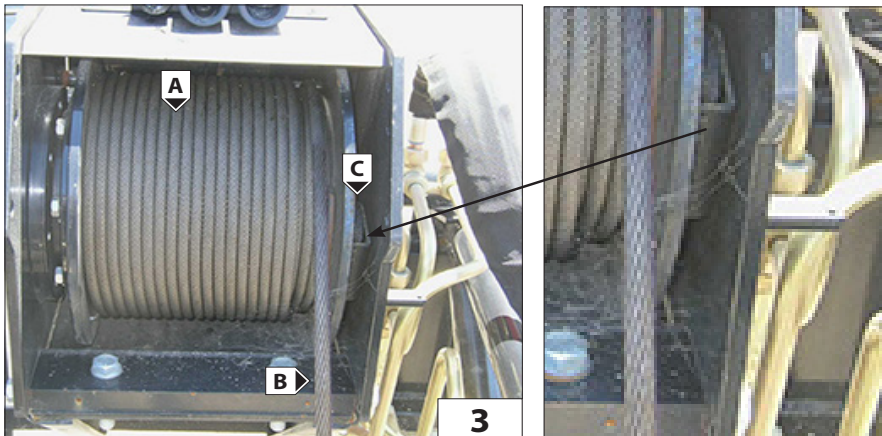



IT

MANUTENZIONE

- RIDUTTORE
- FUNE, PULEGGIA E CAPOCORDA
- BOZZELLO
- GANCIO
- FINE CORSA DISCESA FUNE
- FINE CORSA SALITA FUNE
- IMPIANTO IDRAULICO

US

MAINTENANCE

- REDUCTION GEAR
- ROPE, PULLEY AND CABLE TERMINAL
- PULLEY BLOCK
- HOOK
- ROPE DESCENT LIMIT SWITCH
- ROPE ASCENT LIMIT SWITCH
- HYDRAULIC SYSTEM

NL

ONDERHOUD

- REDUCTOR
- KABEL, KABELSCHIJF en KABELUI-
TEINDEN
- TAKEL
- HAAK
- EINDAANSLAG KABEL OMLAAG
- EINDAANSLAG KABEL OMHOOG
- HYDRAULISCH CIRCUIT



IT

RIDUTTORE

Una corretta lubrificazione consente un buon funzionamento e una lunga durata del riduttore.

Per accedere all'indicatore di livello o al tappo di rabbocco olio, occorre srotolare completamente la fune dal tamburo.

Controllare il livello dell'olio ogni 100 ore A (Fig.6b) e all'occorrenza rabboccare A (Fig.6b) con olio dello stesso tipo di quello presente all'interno del riduttore (SHELL SPIRAX HD80 W90).

Si consiglia l'utilizzo di olio per ingranaggi con additivazione EP con viscosità SAE 80W/90 oppure SAE 85W/140.

La prima sostituzione dell'olio deve essere effettuata dopo 150 ore di funzionamento, successivamente ogni 1000 ore di funzionamento.

Eseguire il cambio dell'olio con riduttore ancora caldo per facilitare un completo svuotamento.

Per scaricare l'olio, ruotare il tamburo del motore portando il tappo di rabbocco / scarico A (Fig.6a) verso il basso. Svitare il tappo A (Fig.6a) e scaricare completamente l'olio.

Ruotare il tamburo portando il foro di rabbocco/scarico sull'asse orizzontale A (Fig.6b).

Rabboccare con olio nuovo e di tipo corretto fino a quando l'olio non fuoriesce da foro di livello A (Fig.6b). (0,6 lt)

Riavvitare i tappi e riavvolgere la fune.

US

REDUCTION GEAR

Correct lubrication allows proper working and longer life of the reduction gear.

To access the level indicator or oil topping up cap, the rope must be unwound completely from the drum.

Check the oil level at least every 100 hours A (Fig.6b) and if required, top up A (Fig.6b) with oil of the same type as that present inside the reduction gear (SHELL SPIRAX HD80 W90).

Use gear oil with additive EP with viscosity SAE 80W/90 or SAE 85W/140.

The first oil change must be after 150 hours of operation, then subsequently every 1000 hours of operation.

Change the oil with the reduction gear still hot to allow complete drainage.

To drain the oil, turn the engine drum so that the filler/drainage cap A (Fig. 6a) is facing downwards.

Unscrew cap A (Fig.6a) and drain out the oil completely.

Turn the drum to bring the topping up/drainage hole horizontal A (Fig.6b).

Top up with fresh oil of the correct type until the oil flows out through the level hole A (Fig.6b).(0.6 l).

Screw the cap back on and rewind the rope.

NL

REDUCTOR

Een correcte smering maakt een goede werking en een lange levensduur van de reductor mogelijk.

Om toegang te verkrijgen tot de oliepeilindicator of de oliebijvuldop, moet de kabel helemaal van de trommel gerold worden.

Controleer het oliepeil om de 100 uren A (Fig.6b) en indien nodig bijvullen A (Fig.6b) met olie van hetzelfde soort als dat aanwezig is in de reductor (SHELL SPIRAX HD80 W90).

Er wordt aangeraden olie voor tandwielen te gebruiken met additievering van EP met viscositeit SAE 80W/90 of SAE 85W/140.

De eerste olieversing moet na 150 werkuren plaatsvinden, daarna om de 1000 werkuren.

Ververs de olie met nog warme reductor om een complete leging te vergemakkelijken.

Om de olie af te voeren, de trommel van de motor zodanig draaien dat de bijvul/aftapdop A (Fig.6a) naar beneden staat.

Draai de dop A (Fig.6a) los en laat alle olie weglopen.

Draai de trommel zodanig dat de bijvul-/aftapopening op de horizontale as staat A (Fig.6b).

Vul bij met nieuwe olie van het juiste type totdat de olie door de oliepeilopening naar buiten komt A (Fig.6b). (0,6 l)

Draai de doppen weer vast en wikkel de kabel weer op.

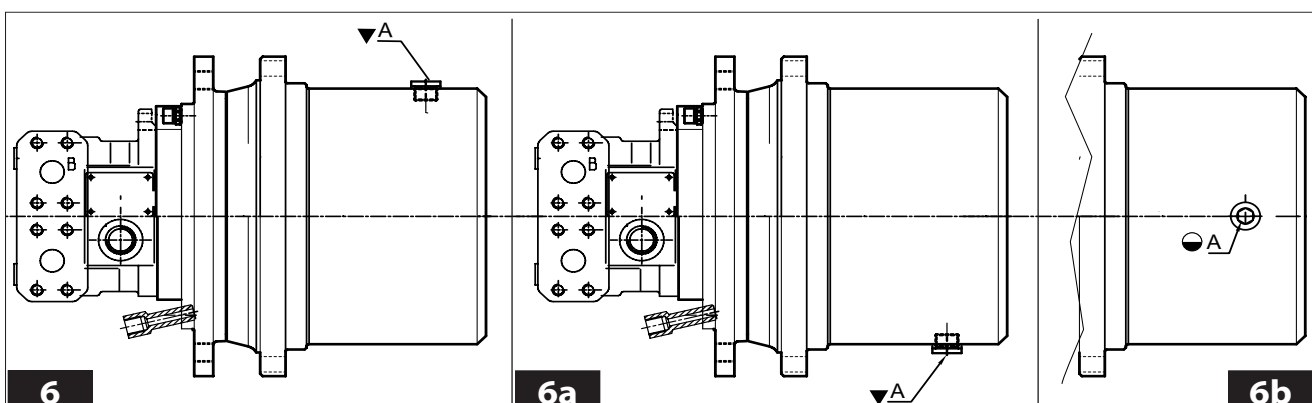
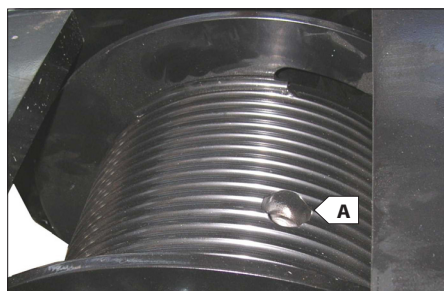

IT

FUNE, PULEGGIA e CAPOCORDA

Controllare giornalmente che la fune A (Fig.7) sia sempre in ottimo stato, che non ci siano filamenti rotti (Fig.7a) e che sia ben arrotolata sul tamburo B (Fig.7).

Altrimenti sostituirla con una nuova e dello stesso diametro e caratteristiche. Controllare la lubrificazione della fune, se necessita lubrificare con grasso industriale oppure olio sintetico anti-polvere.

Controllare e mantenere lubrificato i perni C (Fig.8) su cui ruotano le puleggie di guida D (Fig.8), che dovranno avere sempre un buono movimento di rotazione. Se necessita, lubrificare con grasso al sapone di litio il perno.

Assicurarsi dell'integrità dei capocorda E (Fig.9) e dei suoi morsetti fermafune.

US

ROPE, PULLEY AND CABLE TERMINAL

Check daily to make sure the rope A (Fig.7) is always in excellent condition, that it is not frayed (Fig.7a) and that it is wound perfectly around the drum B (Fig.7).

If necessary replace with a new rope having the same diameter and features. Check the lubrication of the rope, if necessary, lubricate with industrial grease or dust-proof synthetic oil.

Check and lubricate the pins C (Fig. 8) on which the guide pulleys D (Fig. 8) rotate and these must always rotate perfectly. If necessary, lubricate the pin with lithium soap grease.

Ensure the integrity of the cable terminals E (Fig.9) and the rope retainer clamps.

NL

KABEL, KABELSCHIJF en KABELUITEINDEN

Controleer dagelijks of de kabel A (Fig.7) in optimale staat verkeert, of er geen draden stuk zijn (Fig.7a) en of hij goed op de trommel gewonden is B (Fig.7).

Vervang hem anders door een nieuwe met dezelfde diameter en eigenschappen. Controleer de smering van de kabel, indien nodig smeren met industrieel vet of synthetische olie tegen stof.

Controleer de pennen C (Fig.8) waarop de geleideschijven D (Fig.8) draaien en houd ze gesmeerd. Deze moet altijd een goede draaibeweging behouden. Indien nodig, de pen invetten met lithiumzeepvet.

Controleer de staat van de kabeluiteinden E (Fig.9) en de kabelklemmen.

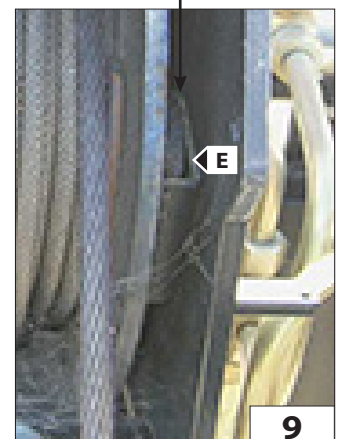
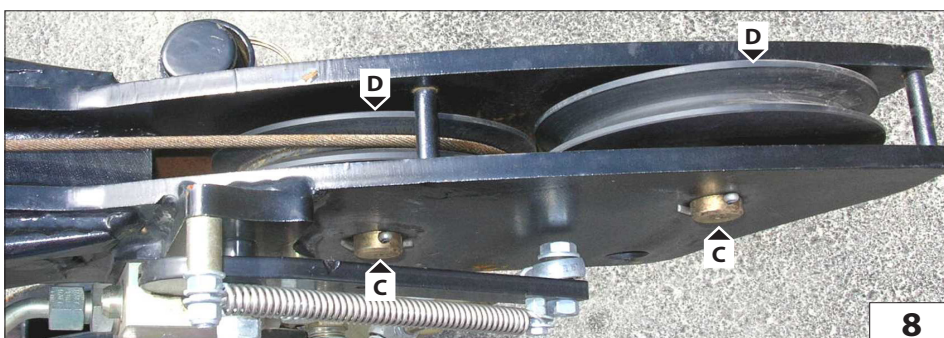
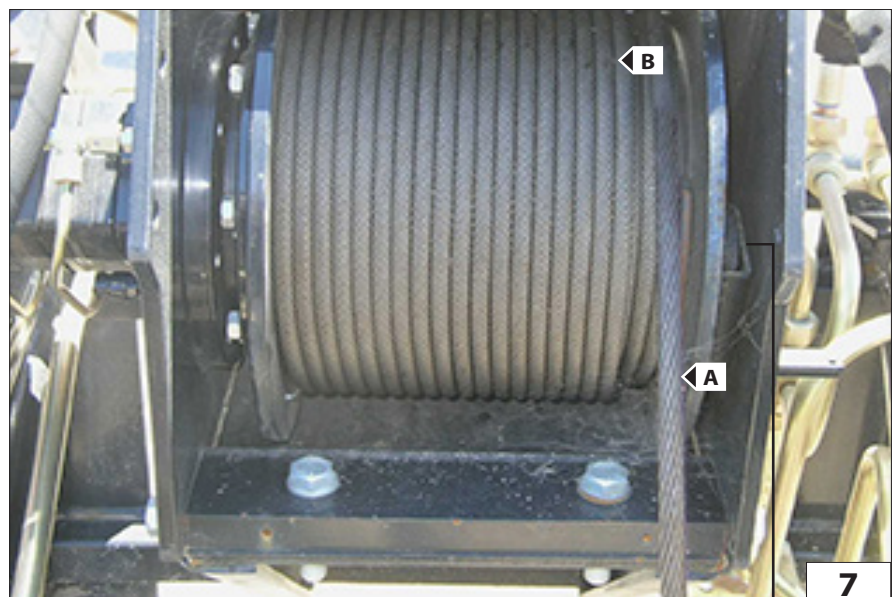
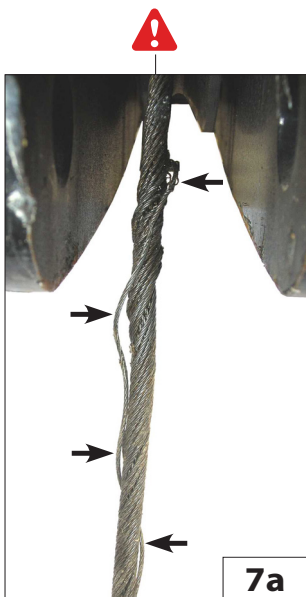

IT

BOZZELLO

Per una massima efficienza e sicurezza, mantenere intatta la struttura esterna F (Fig.10) e controllare che la puleggia G (Fig.10) ruoti correttamente sul suo perno G1 (Fig.10) .
Se necessità, lubrificare con grasso al sapone di litio il perno G1 (Fig.10).

GANCIO

Per una massima efficienza mantenere lubrificata la vite di rotazione del gancio N (Fig.10).
Senza carico sospeso, il gancio deve sempre ruotare liberamente e con la sola pressione della mano P (Fig.10).
Controllare lo stato e l'efficienza della linguetta di sicurezza O (Fig.10).

US

PULLEY BLOCK

For maximum efficiency and safety, keep the external structure F (Fig.10) intact and check to make sure the pulley G (Fig.10) rotates correctly on its pin G1 (Fig.10) .
If necessary, lubricate the pin G1 (Fig.10) with lithium soap grease.

HOOK

For maximum efficiency keep the hook rotation screw N (Fig. 10) lubricated.
Without a load hanging from it, the hook must always rotate freely when pushed slightly by hand P (Fig. 10)..
Check the condition and efficiency of safety tab O (Fig. 10).

NL

TAKEL

Voor een maximale efficiëntie en veiligheid, de buitenste structuur intact houden F (Fig.10) en controleren of de kabelschijf G (Fig.10) goed op zijn pen draait G1 (Fig.10).
Indien nodig, de pen G1 (Fig.10) invetten met lithiumzeepvet.

HAAK

Voor een maximale efficiëntie de draaischroef van de haak N (Fig.10) gesmeerd houden.
Zonder hangende lading moet de haak altijd vrij kunnen draaien door er met de hand tegenaan te drukken P (Fig.10).
Controleer de staat en de efficiëntie van de veiligheidssluiting O (Fig.10).

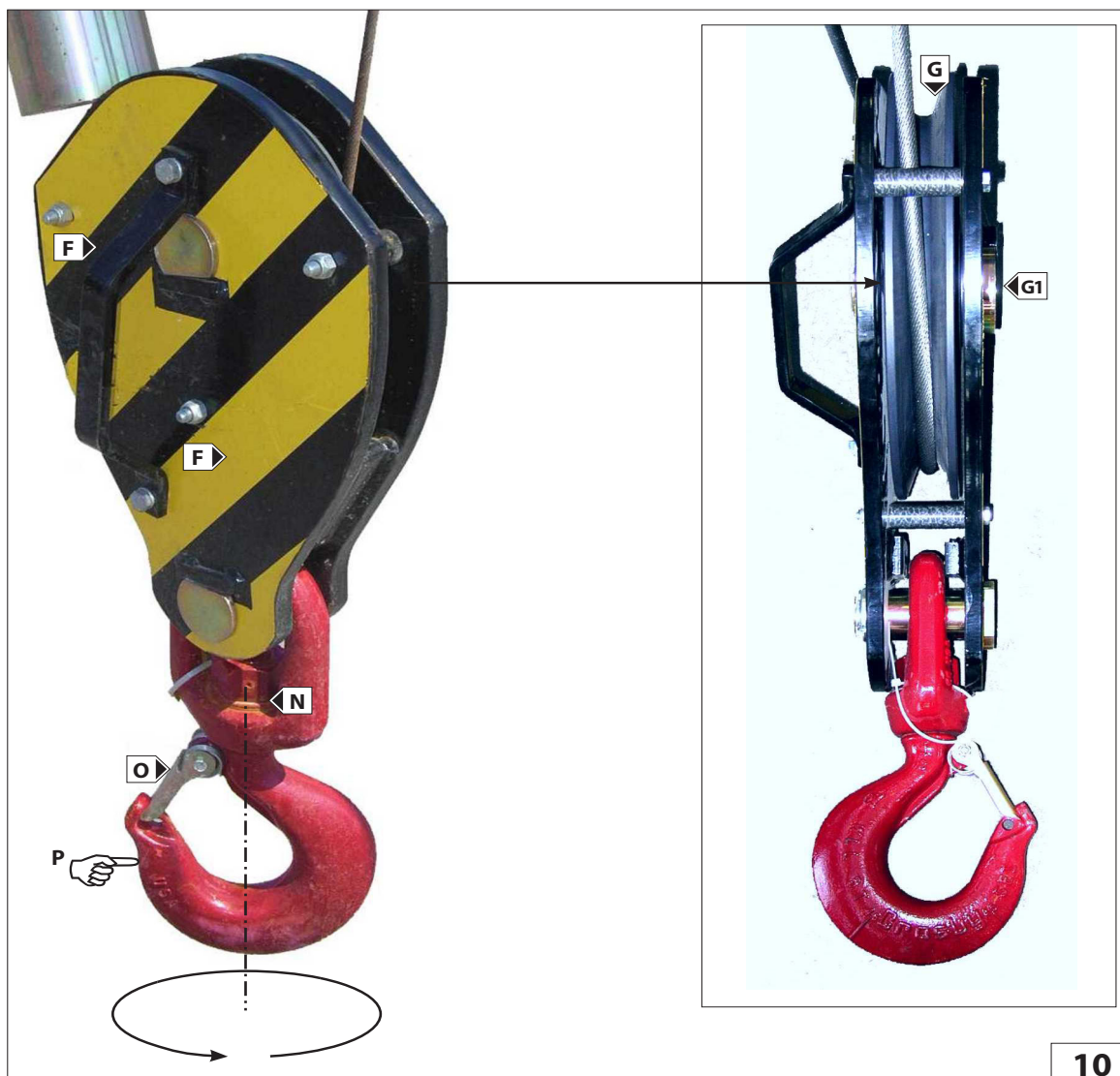

IT

FINE CORSA DISCESA FUNE (Fig.11)

Giornalmente per una massima efficienza mantenere sempre pulito il pistoncino e la valvola idraulica di sicurezza; controllare il serraggio dei raccordi e lo stato dei tubi. Inoltre verificare l'integrità del leveraggio di contatto fincorsa discesa e la tenuta della sua molla.

FINE CORSA SALITA FUNE

Giornalmente per una massima efficienza mantenere sempre pulito il pistoncino e la valvola idraulica di sicurezza; controllare il serraggio dei raccordi e lo stato dei tubi. Inoltre verificare l'integrità del leveraggio di contatto fincorsa salita e la tenuta della sua molla. (Fig.12)

IMPIANTO IDRAULICO (Fig.13)

Ispezionare giornalmente raccordi, valvole, tubi, per evitare eventuali perdite di olio che compromettano il rendimento e la durata dell'organo.

US

ROPE DESCENT LIMIT SWITCH (Fig. 11)

For maximum efficiency, check daily and keep the piston and hydraulic safety valve clean, check to make sure the connections are tightened properly and check the condition of the pipes. Also check the condition of the descent limit switch contact linkages and hold of its spring.

ROPE ASCENT LIMIT SWITCH

For maximum efficiency, check daily and keep the piston and hydraulic safety valve clean, check to make sure the connections are tightened properly and check the condition of the pipes. Also check the condition of the ascent limit switch contact linkages and hold of its spring. (Fig.12)

HYDRAULIC SYSTEM (Fig.13)

Check the connectors, valves, tubes daily to prevent oil leaks which could affect the performance and life of the winch.

NL

EINDAANSLAG KABEL OMLAAG (Fig.11)

Voor een maximale efficiëntie dagelijks altijd het zuigertje en het hydraulische veiligheidsventiel schoon houden; controleer of de verbindingen goed vast zitten en de staat van de leidingen. Controleer eveneens de staat van de hefboven van de eindaanslag voor het dalen en zijn veer.

EINDAANSLAG KABEL OMHOOG

Voor een maximale efficiëntie dagelijks altijd het zuigertje en het hydraulische veiligheidsventiel schoon houden; controleer of de verbindingen goed vast zitten en de staat van de leidingen. Controleer eveneens de staat van de hefboven van de eindaanslag voor het stijgen en zijn veer. (Fig.12)

HYDRAULISCHE INSTALLATIE (Fig.13)

Controleer dagelijks de verbindingstukken, kleppen en leidingen om eventuele olielekken te voorkomen die het rendement en de levensduur van de lier zouden kunnen beïnvloeden.

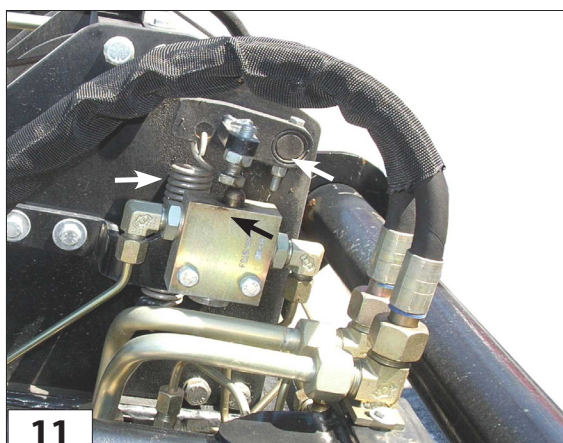
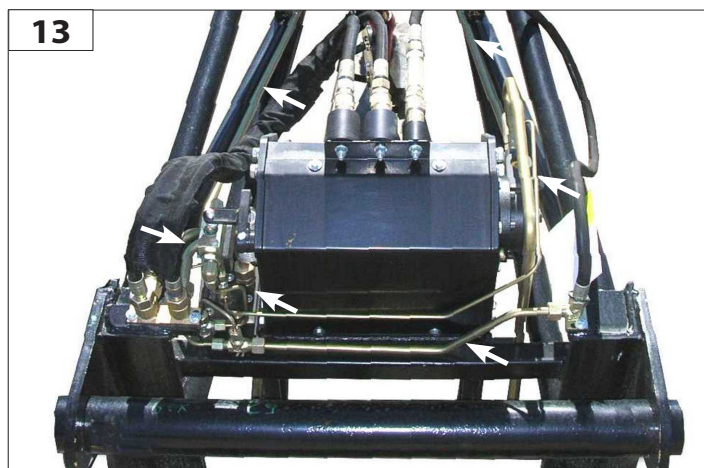

IT

US

NL

SCHEMA IDRAULICO

HYDRAULIC DIAGRAM

HYDRAULISCH SCHEMA

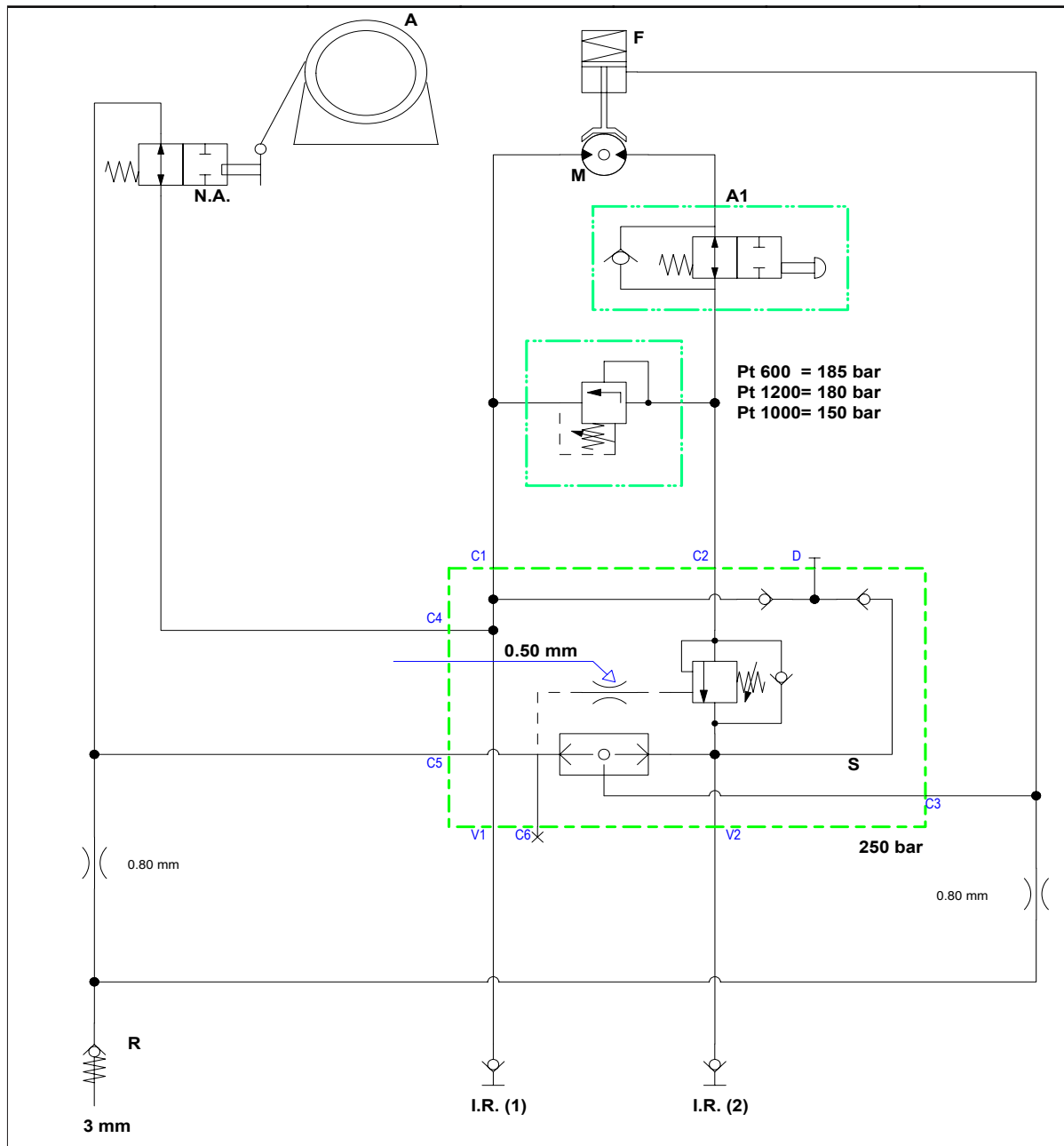

A = ARGANO
N.A. = MICRO MASSIMA DISCESA
R = SERBATOIO OLIO
I.R.1 = INNESTO RAPIDO
I.R.2 = INNESTO RAPIDO
A1 = MICRO MASSIMA SALITA
S = VALVOLA
N = VALVOLA MASSIMA PRESSIONE
M = MOTORE
F = FRENO

A = WINCH
N.A. = MAX. DESCENT MICRO SWITCH
R = OIL TANK
I.R.1 = QUICK-RELEASE COUPLING
I.R.2 = QUICK-RELEASE COUPLING
A1 = MAX. ASCENT MICRO SWITCH
S = VALVE
N = PRESSURE RELIEF VALVE
M = MOTOR
F = BRAKE

A = LIER
N.A. = MICRO MAXIMALE DALING
R = OLIE TANK
I.R.1 = SNELKOPPELING
I.R.2 = SNELKOPPELING
A1 = MICRO MAXIMALE STIJGING
S = VENTIEL
N = MAXIMUMDRUKVENTIEL
M = MOTOR
F = REM



Questa pagina è intenzionalmente vuota
This page is left blank intentionally
Deze pagina is opzettelijk leeg gelaten



PT 1500

IT

Descrizione:

Braccetto lungo 3mt con argano portata 1500Kg.

Caratteristiche:

- Tiro al 3° strato di 1500Kg.
- Velocità massima al 3° strato 46mt/min.
- Il tiro è diretto.
- La fune è di 30mt, diametro 10mm disposta su tre strati.
- Motore orbitale Sauer-Danfoss OMSU.
- Riduttore epicicloidale con freno negativo a dischi in bagno d'olio.
- Il tamburo è filettato e dotato di un rullo pressa fune in modo da assicurare sempre un corretto avvolgimento della fune.
- Classificazione ISO 4301/1: T4,L2,M4.

Sicurezze:

- Fine corsa discesa idraulico positivo
- Fine corsa salita idraulico positivo

US

Description:

3m long arm with carrying capacity of 1500 kg.

Features:

- Pull at 3rd layer 1500kg.
- Maximum speed at 3rd layer 46 m/min
- The pull is direct
- The rope is 30 m long, 10mm diameter arranged in three layers.
- Sauer-Danfoss OMSU orbital motor.
- Planetary drive with negative oil bath disk brake
- The drum is threaded and provided with a rope press roller in order to always ensure correct winding of the rope.
- ISO 4301/1 Classification: T4, L2, M4.

Safety devices:

- Positive hydraulic descent limit switch
- Positive hydraulic ascent limit switch

NL

Beschrijving:

3 m lange arm met lier met draagvermogen van 1500 kg.

Kenmerken:

- Trekkracht 3de laag 1500 kg.
- Maximumsnelheid 3de laag 46 m/min.
- Kabel enkel gebruikt.
- De kabel is 30 m, diameter 10 mm in drie lagen.
- Sauer-Danfoss OMSU orbitmotor.
- Planetaire reductor met negatieve schijvenrem in oliebad.
- De trommel is gegleufd en voorzien van een kabelandrukrol voor een altijd correcte opwikkeling van de kabel.
- Classificatie ISO 4301/1: T4,L2,M4.

Beschermingen:

- Positieve hydraulische eindaanslag daling
- Positieve hydraulische eindaanslag stijging





[kg] (lb)	[t] (t)	[mm] (in) x [m] (ft)	[m/min] (ft/min)	[bar] (psi)	[mm] (in)						[kg] (lb)
				P max							
1200 (2204)	5 (5)	Ø 10 (0,4) x 30 (98)	46 (150)	200 (2900)	A	B	C	D	E	F	360 (793)
					750 (29)	117 (4)	734 (29)	2692 (106)	2980 (117)	586 (23)	

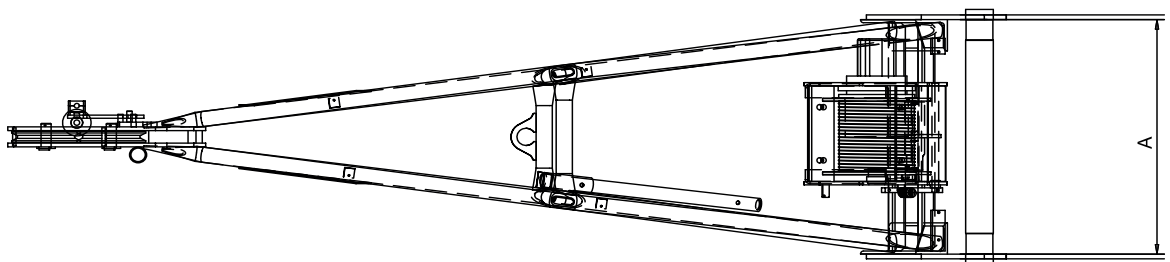
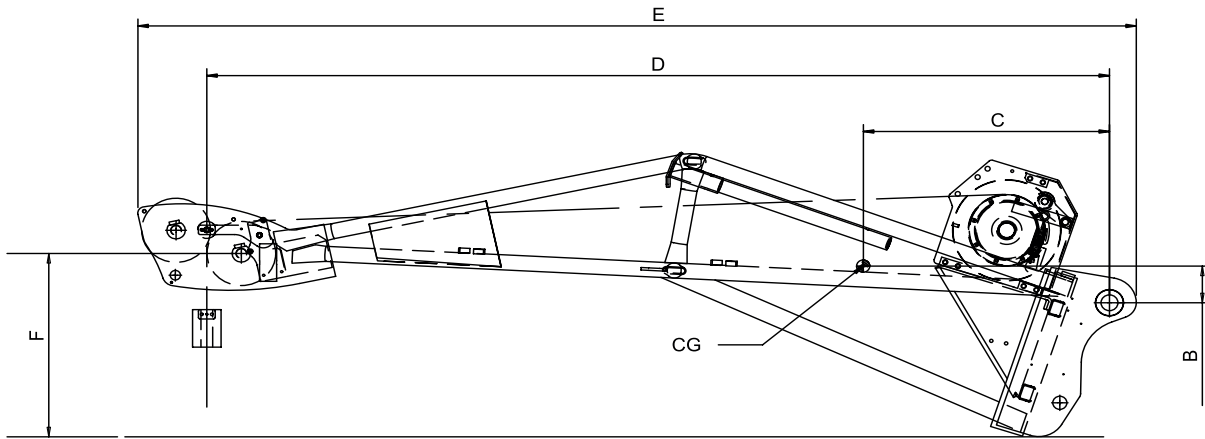

IT

PT 1500

MESSA IN SERVIZIO E UTILIZZO

Per la vostra sicurezza, prima di iniziare un ciclo di lavoro, attenersi alle **Istruzioni obbligatorie di verifica e controllo:**

- verificare l'integrità della struttura esterna dell'argano e del braccetto tralicciato.
- verificare il corretto collegamento idraulico degli innesti rapidi 1, 2, Drenaggio e lo stato dei tubi flessibili (Fig.1);
- controllare il corretto funzionamento del fine corsa discesa fune L (Fig.2);
- controllare il corretto funzionamento del fine corsa salita fune H (Fig.2);

US

PT 1500

STARTING UP AND USE

For your safety, before starting a work cycle, follow the Compulsory instructions for inspection and control:

- check to make sure the external structure of the winch and latticed boom is intact.
- Check to ensure the correct hydraulic connection of quick-release couplings 1, 2, drainage and the condition of the hose pipes (Fig.1);
- check to ensure correct working of the rope ascent limit switch L (Fig.2);
- check to ensure correct working of the rope descent limit switch H (Fig.2);

NL

PT 1500

INBEDRIJFSTELLING EN GEBRUIK

Houd u, voor uw eigen veiligheid, voor met een werkcyclus aan te vangen, aan de verplichte controle-instructies:

- controleer of de buitenste structuur van de lier en van de vakwerkarm intact is.
- controleer of de hydraulische verbinding van de snelkoppelingen 1, 2, Afvoer en de staat van de slangen in orde zijn (Fig.1);
- controleer de werking van de eindaanslag kabel omlaag L (Fig.2);
- controleer de werking van de eindaanslag kabel omhoog H (Fig.2);

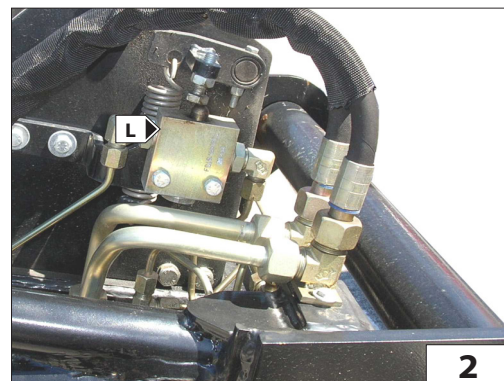
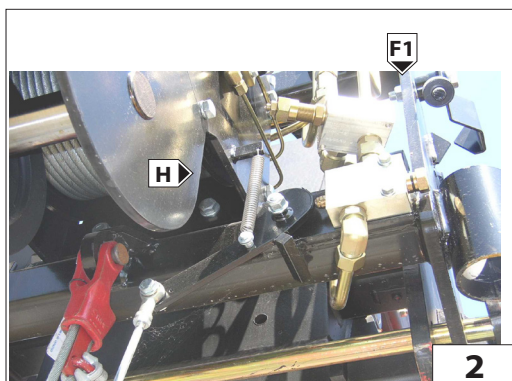
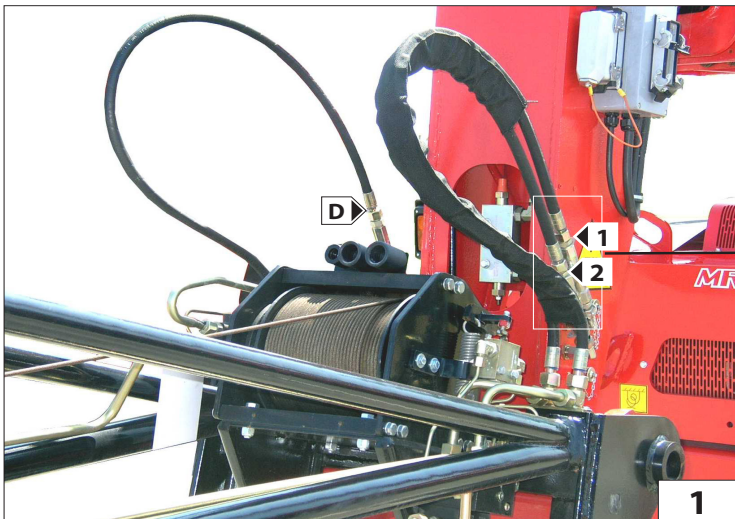

IT

- controllare lo stato della fune B (Fig.3) e il corretto avvolgimento sul tamburo A (Fig.3);
- controllare il corretto movimento rotazione delle pulegge di guida fune F1 (Fig.2);
- controllare lo stato del capocorda C (Fig.3);
- controllare che il grillo di collegamento fune e gancio sia ben avvitato K (Fig.4) e che i morsetti K1 (Fig.4) bloccino la fune.
- verificare lo stato del gancio: che non sia deformato, che ruoti liberamente e che la linguetta di sicurezza sia efficiente G (Fig.4);
- controllare l'aggancio del braccetto alla macchina operatrice J (Fig.5).

US

- check the condition of the rope B (Fig. 3) and that it is wound correctly on the drum A (Fig.3);
- check to ensure correct rotation movement of the rope guide pulley F1 (Fig.2);
- check the condition of cable terminal C (Fig. 3);
- check to make sure the rope and hook connecting shackle is screwed in properly K (Fig.4) and that the terminals K1 (Fig.4) block the rope;
- check the condition of the hook: to make sure it is not deformed, that it rotates freely and that the safety tab G (Fig. 4) is in working order;
- check the hook-up of the boom to the operating machine J (Fig. 5).

NL

- controleer de staat van de kabel B (Fig.3) en de opwikkeling op de trommel A (Fig.3);
- controleer de draibeweging van de kabelgeleidewielen F1 (Fig.2);
- controleer de staat van het kabeluiteinde C (Fig.3);
- controleer of de harpsluiting tussen de kabel en de haak K (Fig.4) goed vastgedraaid is en of de klemmen K1 (Fig.4) de kabel blokkeren.
- controleer de staat van de haak: of deze niet vervormd is, of hij vrij draait en of zijn veiligheidssluiting efficiënt is G (Fig.4);
- controleer de aankoppeling van de arm aan de machine J (Fig.5).

Dalla posizione di parcheggio è possibile sganciare il piede di appoggio e posizionarlo all'interno del braccetto per operare senza ulteriori ingombri J1 (Fig.5).

From the parking position it is possible to unhook the foot and position it inside the boom to operate without increasing the dimensions J1 (Fig.5).

Vanuit de parkeerstand kan de steunpoot losgemaakt worden en binnenin de arm geplaatst worden om zonder onnodige ruimte innemende structuren te kunnen werken J1 (Fig.5).

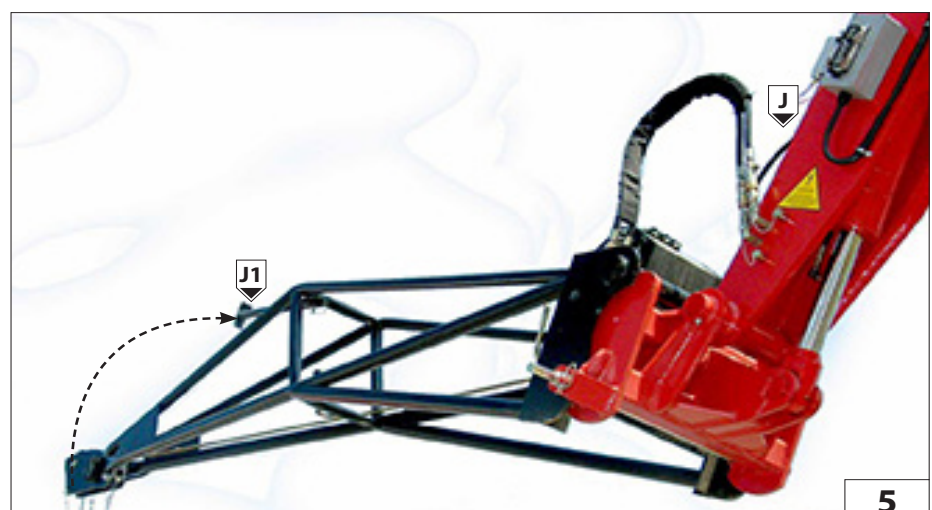
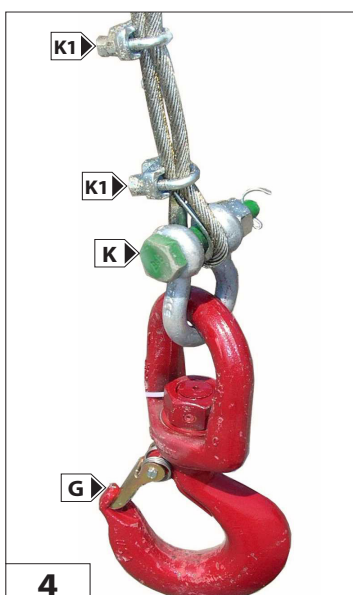
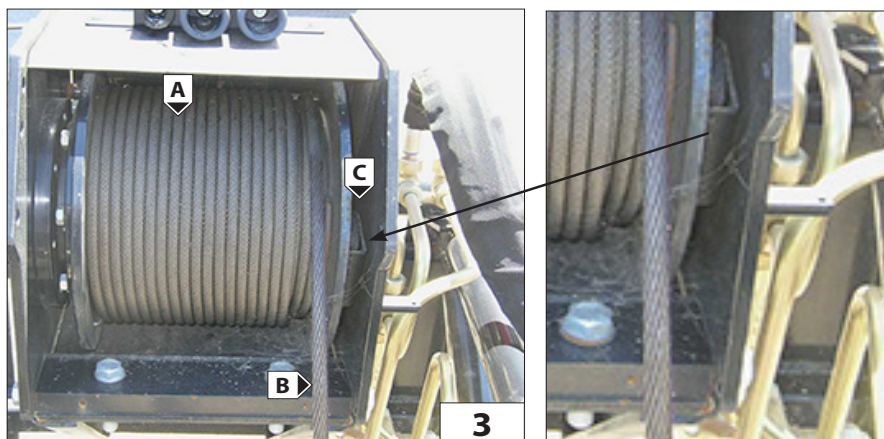



IT

MANUTENZIONE

- RIDUTTORE
- FUNE, PULEGGIA E CAPOCORDA
- BOZZELLO
- GANCIO
- FINE CORSA DISCESA FUNE
- FINE CORSA SALITA FUNE
- IMPIANTO IDRAULICO

US

MAINTENANCE

- REDUCTION GEAR
- ROPE, PULLEY AND CABLE TERMINAL
- PULLEY BLOCK
- HOOK
- ROPE DESCENT LIMIT SWITCH
- ROPE ASCENT LIMIT SWITCH
- HYDRAULIC SYSTEM

NL

ONDERHOUD

- REDUCTOR
- KABEL, KABELSCHIJF en KABELUI-
TEINDEN
- TAKEL
- HAAK
- EINDAANSLAG KABEL OMLAAG
- EINDAANSLAG KABEL OMHOOG
- HYDRAULISCH CIRCUIT



IT

RIDUTTORE

Una corretta lubrificazione consente un buon funzionamento e una lunga durata del riduttore.

Per accedere all'indicatore di livello o al tappo di rabbocco olio, occorre srotolare completamente la fune dal tamburo.

Controllare il livello dell'olio ogni 100 ore A (Fig.6b) e all'occorrenza rabboccare A (Fig.6b) con olio dello stesso tipo di quello presente all'interno del riduttore (SHELL SPIRAX HD80 W90).

Si consiglia l'utilizzo di olio per ingranaggi con additivazione EP con viscosità SAE 80W/90 oppure SAE 85W/140.

La prima sostituzione dell'olio deve essere effettuata dopo 150 ore di funzionamento, successivamente ogni 1000 ore di funzionamento.

Eseguire il cambio dell'olio con riduttore ancora caldo per facilitare un completo svuotamento.

Per scaricare l'olio, ruotare il tamburo del motore portando il tappo di rabbocco / scarico A (Fig.6a) verso il basso. Svitare il tappo A (Fig.6a) e scaricare completamente l'olio.

Ruotare il tamburo portando il foro di rabbocco/scarico sull'asse orizzontale A (Fig.6b).

Rabboccare con olio nuovo e di tipo corretto fino a quando l'olio non fuoriesce da foro di livello A (Fig.6b). (0,6 lt) Riavvitare i tappi e riavvolgere la fune.

US

REDUCTION GEAR

Correct lubrication allows proper working and longer life of the reduction gear.

To access the level indicator or oil topping up cap, the rope must be unwound completely from the drum.

Check the oil level at least every 100 hours A (Fig.6b) and if required, top up A (Fig.6b) with oil of the same type as that present inside the reduction gear (SHELL SPIRAX HD80 W90).

Use gear oil with additive EP with viscosity SAE 80W/90 or SAE 85W/140.

The first oil change must be after 150 hours of operation, then subsequently every 1000 hours of operation.

Change the oil with the reduction gear still hot to allow complete drainage.

To drain the oil, turn the engine drum so that the filler/drainage cap A (Fig. 6a) is facing downwards.

Unscrew cap A (Fig.6a) and drain out the oil completely.

Turn the drum to bring the topping up/drainage hole horizontal A (Fig.6b).

Top up with fresh oil of the correct type until the oil flows out through the level hole A (Fig.6b). (0.6 l).

Screw the cap back on and rewind the rope.

NL

REDUCTOR

Een correcte smering maakt een goede werking en een lange levensduur van de reductor mogelijk.

Om toegang te verkrijgen tot de oliepeilindicator of de oliebijkvuldop, moet de kabel helemaal van de trommel gerold worden.

Controleer het oliepeil om de 100 uren A (Fig.6b) en indien nodig bijvullen A (Fig.6b) met olie van hetzelfde soort als dat aanwezig is in de reductor (SHELL SPIRAX HD80 W90).

Er wordt aangeraden olie voor tandwielen te gebruiken met additievering van EP met viscositeit SAE 80W/90 of SAE 85W/140.

De eerste olieerversing moet na 150 werkuren plaatsvinden, daarna om de 1000 werkuren.

Ververs de olie met nog warme reductor om een complete leging te vergemakkelijken.

Om de olie af te voeren, de trommel van de motor zodanig draaien dat de bijvul/aftapdop A (Fig.6a) naar beneden staat.

Draai de dop A (Fig.6a) los en laat alle olie weglopen.

Draai de trommel zodanig dat de bijvul-/aftapopening op de horizontale as staat A (Fig.6b).

Vul bij met nieuwe olie van het juiste type totdat de olie door de oliepeilopening naar buiten komt A (Fig.6b). (0,6 l) Draai de doppen weer vast en wikkel de kabel weer op.

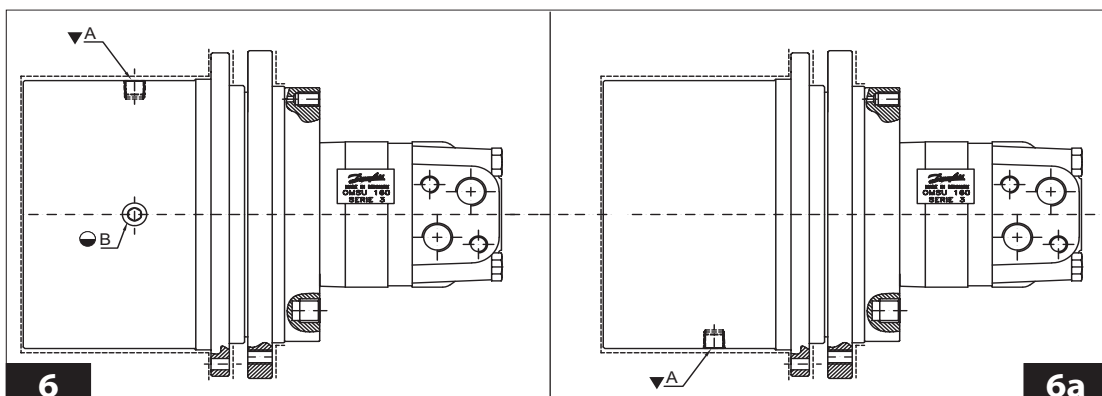
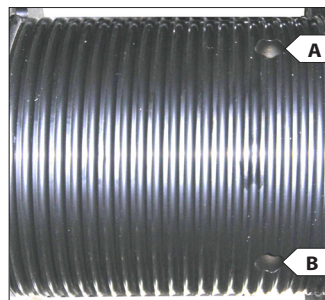

IT

FUNE, PULEGGIA e CAPOCORDA

Controllare giornalmente che la fune A (Fig.7) sia sempre in ottimo stato, che non ci siano filamenti rotti (Fig.7a) e che sia ben arrotolata sul tamburo B (Fig.7).

Altrimenti sostituirla con una nuova e dello stesso diametro e caratteristiche. Controllare la lubrificazione della fune, se necessita lubrificare con grasso industriale oppure olio sintetico anti-polvere.

Controllare e mantenere lubrificato i perni C (Fig.8) su cui ruotano le pulegge di guida D (Fig.8), che dovranno avere sempre un buono movimento di rotazione.

Se necessita, lubrificare con grasso al sapone di litio il perno.

Assicurarsi dell'integrità dei capocorda E (Fig.9) e dei suoi morsetti fermafune.

US

ROPE, PULLEY AND CABLE TERMINAL

Check daily to make sure the rope A (Fig.7) is always in excellent condition, that it is not frayed (Fig.7a) and that it is wound perfectly around the drum B (Fig.7).

If necessary replace with a new rope having the same diameter and features. Check the lubrication of the rope, if necessary, lubricate with industrial grease or dust-proof synthetic oil.

Check and lubricate the pins C (Fig. 8) on which the guide pulleys D (Fig. 8) rotate and these must always rotate perfectly.

If necessary, lubricate the pin with lithium soap grease.

Ensure the integrity of the cable terminals E (Fig.9) and the rope retainer clamps.

NL

KABEL, KABELSCHIJF en KABELUITEINDEN

Controleer dagelijks of de kabel A (Fig.7) in optimale staat verkeert, of er geen draden stuk zijn (Fig.7a) en of hij goed op de trommel gewonden is B (Fig.7).

Vervang hem anders door een nieuwe met dezelfde diameter en eigenschappen.

Controleer de smering van de kabel, indien nodig smeren met industrieel vet of synthetische olie tegen stof.

Controleer de pennen C (Fig.8) waarop de geleideschijven D (Fig.8) draaien en houd ze gesmeerd. Deze moet altijd een goede draibeweging behouden. Indien nodig, de pen invetten met lithiumzeepvet.

Controleer de staat van de kabeluiteinden E (Fig.9) en de kabelklemmen.

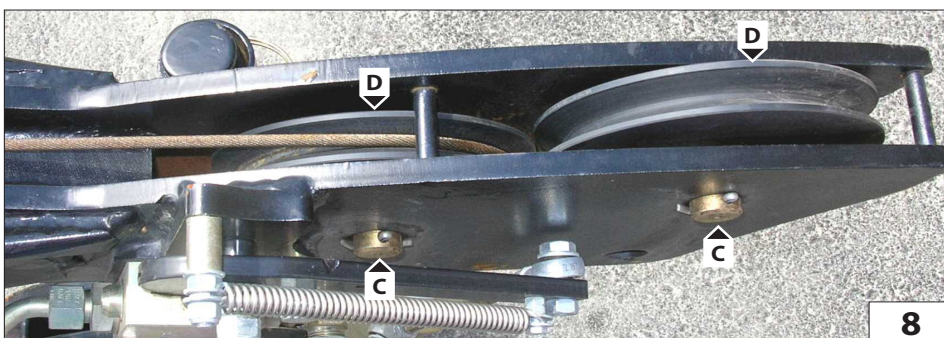
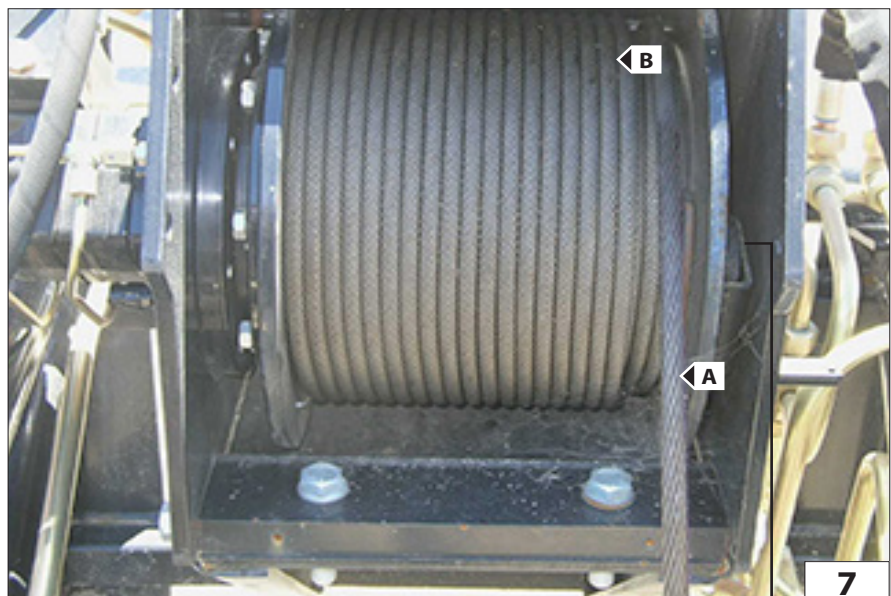
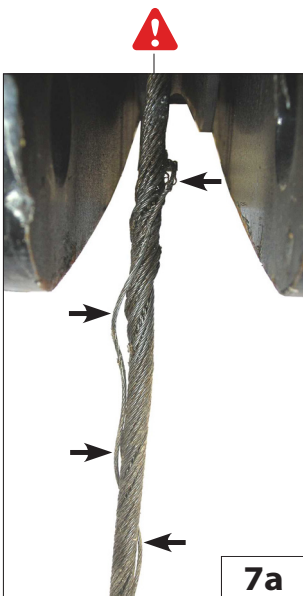

IT

GRILLO E MORSETTI

È importante verificare l'integrità e il serraggio delle viti dei morsetti F (Fig.10) e del bullone del grillo G (Fig.10) una volta alla settimana.

GANCIO

Per una massima efficienza mantenere lubrificata la vite di rotazione del gancio N (Fig.10).
Senza carico sospeso, il gancio deve sempre ruotare liberamente e con la sola pressione della mano P (Fig.10).
Controllare lo stato e l'efficienza della linguetta di sicurezza O (Fig.10).

US

SHACKLE AND TERMINALS

Check the condition and tightening of the screws of terminals F (Fig. 10) and the bolt of shackle G (Fig. 10) once a week.

HOOK

For maximum efficiency keep the hook rotation screw N (Fig. 10) lubricated.
Without a load hanging from it, the hook must always rotate freely when pushed slightly by hand P (Fig. 10)..
Check the condition and efficiency of safety tab O (Fig. 10).

NL

HARPSLUITING EN KLEMMEN

Het is van belang de staat en de aandrijving van de schroeven van de klemmen F (Fig.10) en van de bout van de harpsluiting G (Fig.10) eens in de week na te kijken.

HAAK

Voor een maximale efficiëntie de draaischroef van de haak N (Fig.10) gesmeerd houden.
Zonder hangende lading moet de haak altijd vrij kunnen draaien door er met de hand tegenaan te drukken P (Fig.10).
Controleer de staat en de efficiëntie van de veiligheidsluiting O (Fig.10).

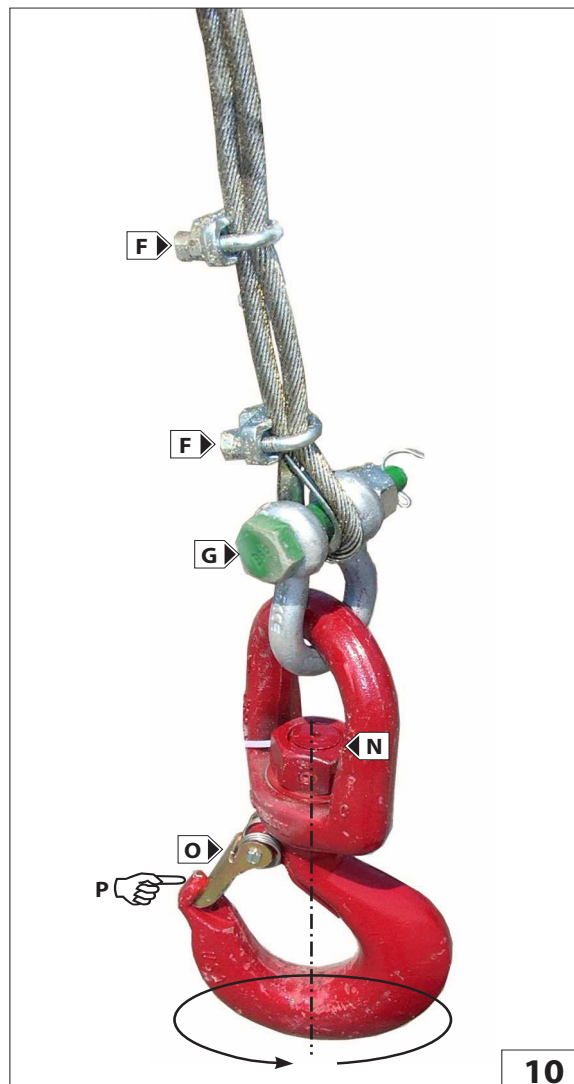

IT

FINE CORSA DISCESA FUNE (Fig.11)

Giornalmente per una massima efficienza mantenere sempre pulito il pistoncino e la valvola idraulica di sicurezza; controllare il serraggio dei raccordi e lo stato dei tubi. Inoltre verificare l'integrità del leveraggio di contatto fincorsa discesa e la tenuta della sua molla.

FINE CORSA SALITA FUNE

Giornalmente per una massima efficienza mantenere sempre pulito il pistoncino e la valvola idraulica di sicurezza; controllare il serraggio dei raccordi e lo stato dei tubi. Inoltre verificare l'integrità del leveraggio di contatto fincorsa salita e la tenuta della sua molla. (Fig.12)

IMPIANTO IDRAULICO (Fig.13)

Ispezionare giornalmente raccordi, valvole, tubi, per evitare eventuali perdite di olio che compromettano il rendimento e la durata dell'argano.

US

ROPE DESCENT LIMIT SWITCH (Fig. 11)

For maximum efficiency, check daily and keep the piston and hydraulic safety valve clean, check to make sure the connections are tightened properly and check the condition of the pipes. Also check the condition of the descent limit switch contact linkages and hold of its spring.

ROPE ASCENT LIMIT SWITCH

For maximum efficiency, check daily and keep the piston and hydraulic safety valve clean, check to make sure the connections are tightened properly and check the condition of the pipes. Also check the condition of the ascent limit switch contact linkages and hold of its spring. (Fig.12)

HYDRAULIC SYSTEM (Fig.13)

Check the connectors, valves, tubes daily to prevent oil leaks which could affect the performance and life of the winch.

NL

EINDAANSLAG KABEL OMLAAG (Fig.11)

Voor een maximale efficiëntie dagelijks altijd het zuigertje en het hydraulische veiligheidsventiel schoon houden; controleer of de verbindingen goed vast zitten en de staat van de leidingen. Controleer eveneens de staat van de hefbomen van de eindaanslag voor het dalen en zijn veer.

EINDAANSLAG KABEL OMHOOG

Voor een maximale efficiëntie dagelijks altijd het zuigertje en het hydraulische veiligheidsventiel schoon houden; controleer of de verbindingen goed vast zitten en de staat van de leidingen. Controleer eveneens de staat van de hefbomen van de eindaanslag voor het stijgen en zijn veer. (Fig.12)

HYDRAULISCHE INSTALLATIE (Fig.13)

Controleer dagelijks de verbindingstukken, kleppen en leidingen om eventuele olielekken te voorkomen die het rendement en de levensduur van de lier zouden kunnen beïnvloeden.

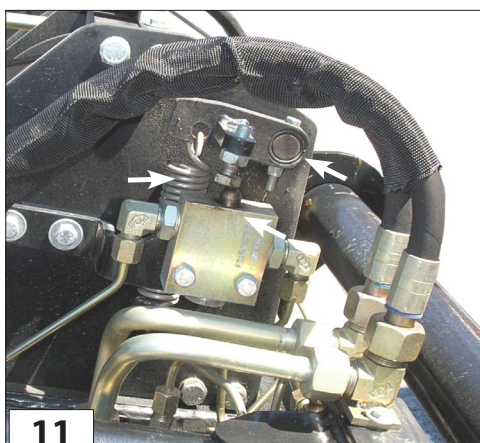
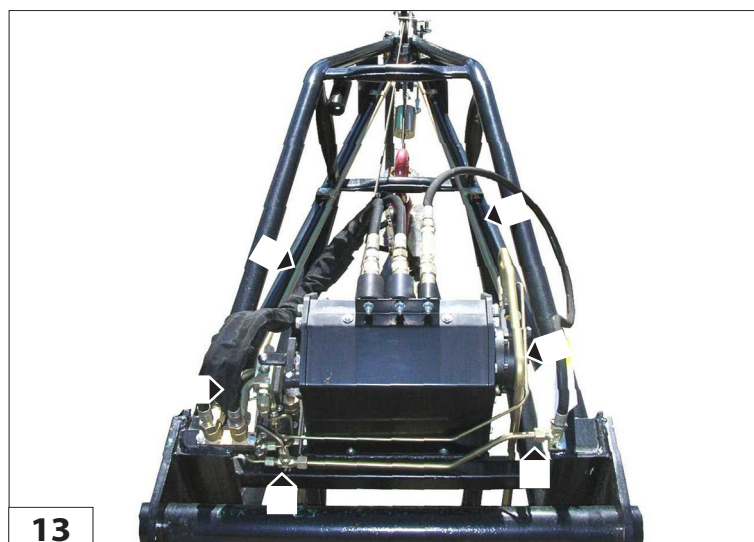

IT

US

NL

SCHEMA IDRAULICO

HYDRAULIC DIAGRAM

HYDRAULISCH SCHEMA

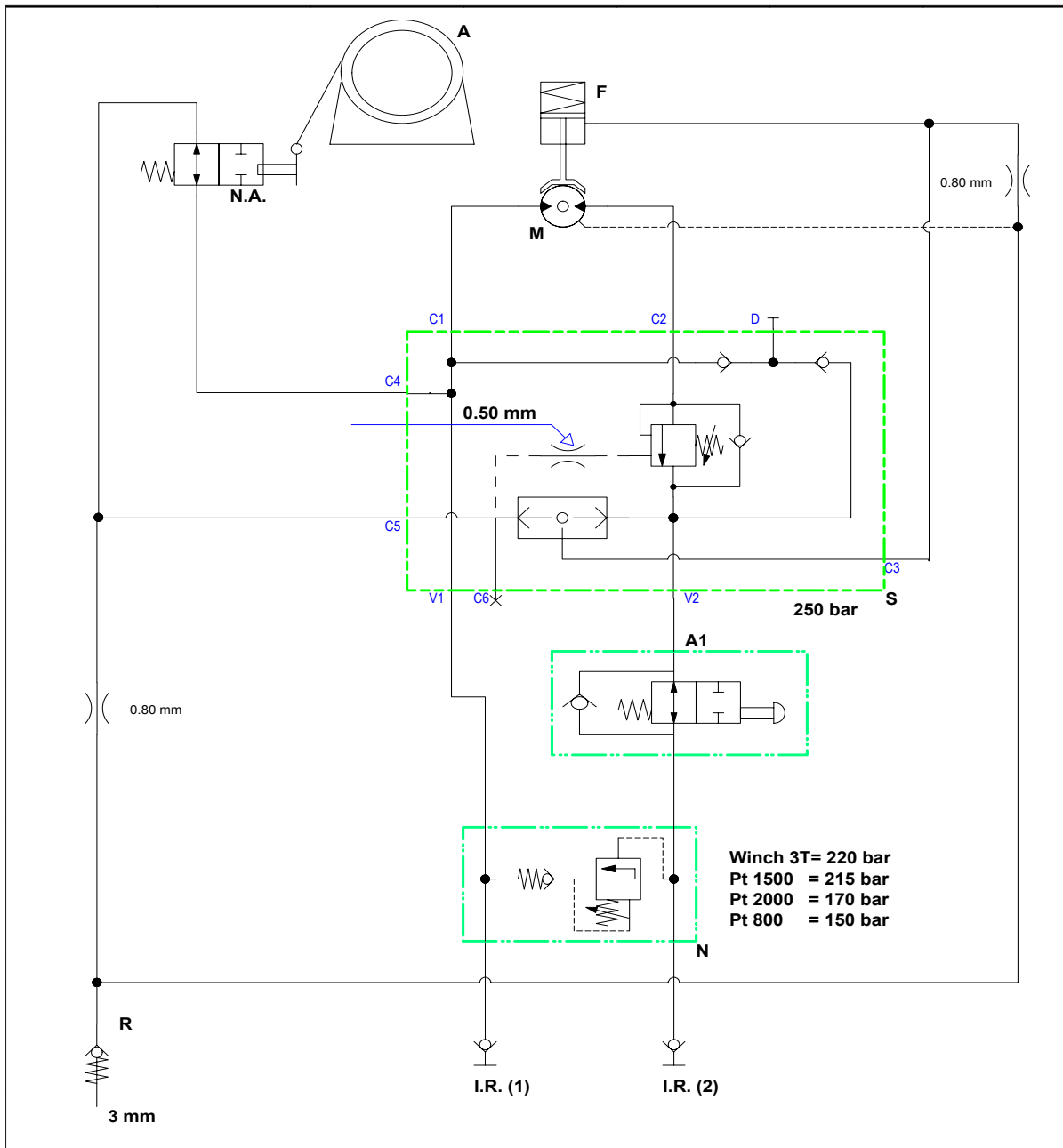

A = ARGANO
N.A. = MICRO MASSIMA DISCESA
R = SERBATOIO OLIO
I.R.1 = INNESTO RAPIDO
I.R.2 = INNESTO RAPIDO
A1 = MICRO MASSIMA SALITA
S = VALVOLA
N = VALVOLA MASSIMA PRESSIONE
M = MOTORE
F = FRENO

A = WINCH
N.A. = MAX. DESCENT MICRO SWITCH
R = OIL TANK
I.R.1 = QUICK-RELEASE COUPLING
I.R.2 = QUICK-RELEASE COUPLING
A1 = MAX. ASCENT MICRO SWITCH
S = VALVE
N = PRESSURE RELIEF VALVE
M = MOTOR
F = BRAKE

A = LIER
N.A. = MICRO MAXIMALE DALING DISCESA
R = OLJETANK
I.R.1 = SNELKOPPELING
I.R.2 = SNELKOPPELING
A1 = MICRO MAXIMALE STIJING SALITA
S = VENTIEL
N = MAXIMUMDRUKVENTIEL
M = MOTOR
F = REM



Questa pagina è intenzionalmente vuota
This page is left blank intentionally
Deze pagina is opzettelijk leeg gelaten



PT 2000

IT

Descrizione:

Falcone lungo 2,5 mt con argano portata 2000Kg.

Caratteristiche:

- Tiro al 3° strato di 2000Kg.
- Velocità massima al 3° strato 23mt/min
- Il tiro è in due taglie.
- La fune è di 46mt, diametro 10mm disposta su tre strati.
- Motore orbitale Sauer-Danfoss OMSU.
- Riduttore epicicloidale con freno negativo a dischi in bagno d'olio.
- Il tamburo è filettato e dotato di un rullo pressa fune in modo da assicurare sempre un corretto avvolgimento della fune.
- Presenza di un guida fune che migliora ulteriormente l'avvolgimento della fune sul tamburo.
- Classificazione ISO 4301/1: T4,L2,M4.

Sicurezza:

- Fine corsa discesa idraulico positivo.
- Fine corsa salita idraulico positivo.

US

Description:

2.5m long derrick with winch having capacity of 2000 kg.

Features:

- Pull at 3rd layer 2000 kg.
- Max. speed at 3rd layer 23m/min
- The pull is in two sheaves.
- The rope is 46 m long, 10mm diameter arranged in three layers.
- Sauer-Danfoss OMSU orbital motor.
- Planetary drive with negative oil bath disk brake
- The drum is threaded and provided with a rope press roller in order to always ensure correct winding of the rope.
- Presence of a rope guide which further improves the winding of the rope on the drum.
- ISO 4301/1 Classification: T4, L2, M4.

Safety devices:

- Positive hydraulic descent limit switch.
- Positive hydraulic ascent limit switch.

NL

Beschrijving:

2,5 m lange arm met lier met vermogen van 2000 kg.

Kenmerken:

- Trekkracht 3de laag 2000 kg.
- Maximalsnelheid 3de laag 23 m/min.
- Kabel dubbel gebruikt.
- De kabel is 46 m, diameter 10 mm in drie lagen.
- Sauer-Danfoss OMSU orbitmotor.
- Planetaire reductor met negatieve schijvenrem in oliebad.
- De trommel is gegleufd en voorzien van een kabelandrukrol voor een altijd correcte opwikkeling van de kabel.
- Aanwezigheid van een kabelgeleider voor een nog betere opwikkeling van de kabel op de trommel.
- Classificatie ISO 4301/1: T4,L2,M4.

Beschermingen:

- Positieve hydraulische eindaanslag daling.
- Positieve hydraulische eindaanslag stijging.





[kg] (lb)	[t] (t)	[mm] (in) x [m] (ft)	[m/min] [ft/min]	[bar] (psi)	[mm] (in)							[kg] (lb)
				P max								
2000 (4409)	5 (5)	Ø 10 (0,4) x 46 (150)	23 (75)	170 (2465)	A	B	C	D	E	F	G	354 (780)
					15 (0,5)	750 (29)	62 (2)	841 (33)	2226 (88)	2517 (99)	657 (26)	

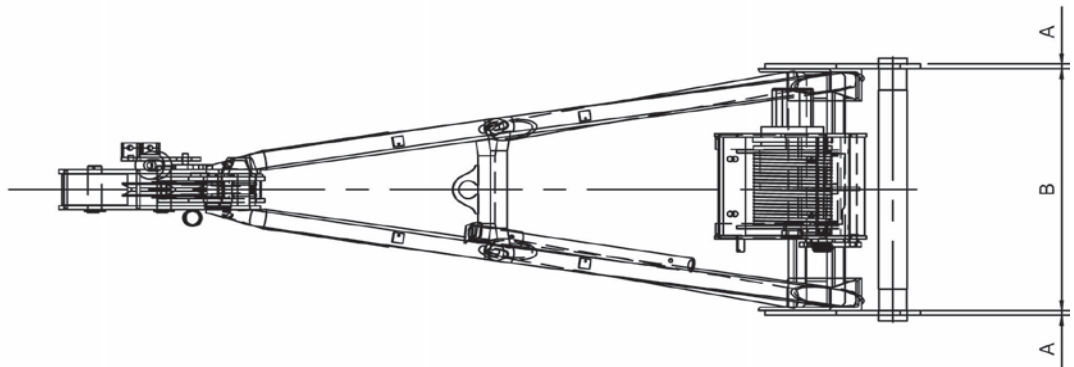
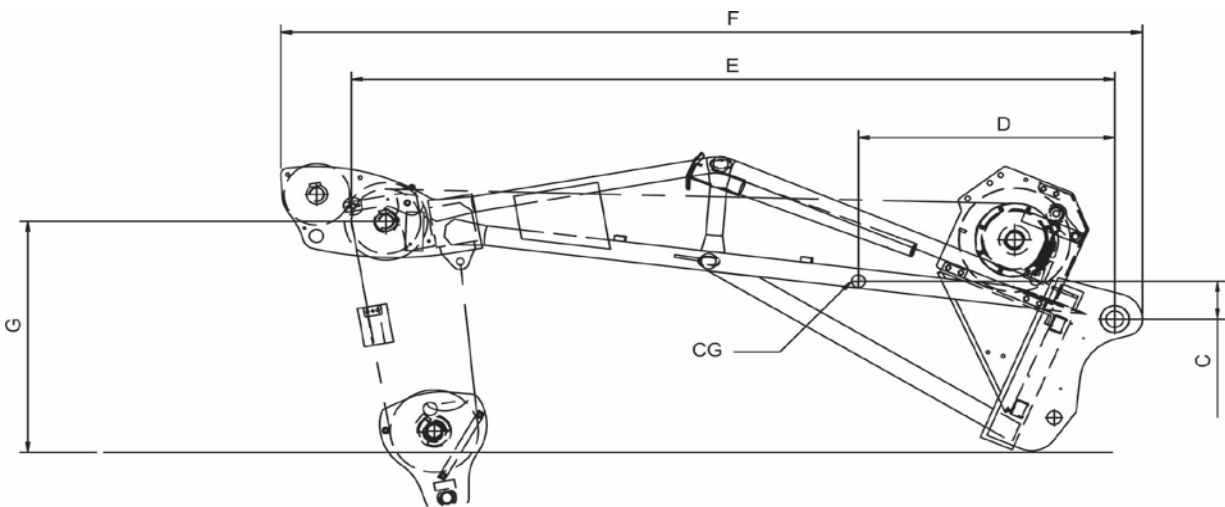

IT

PT 2000

MESSA IN SERVIZIO E UTILIZZO

Per la vostra sicurezza, prima di iniziare un ciclo di lavoro, attenersi alle Istruzioni obbligatorie di verifica e controllo:

- verificare l'integrità della struttura esterna dell'argano e del braccetto tralicciato.
- verificare il corretto collegamento idraulico degli innesti rapidi 1, 2, Drenaggio e lo stato dei tubi flessibili (Fig.1);
- controllare il corretto funzionamento del fine corsa discesa fune L (Fig.2);
- controllare il corretto funzionamento del fine corsa salita fune H (Fig.2);

US

PT 2000

STARTING UP AND USE

For your safety, before starting a work cycle, follow the Compulsory instructions for inspection and control:

- check to make sure the external structure of the winch and latticed boom is intact.
- Check to ensure the correct hydraulic connection of quick-release couplings 1, 2, drainage and the condition of the hose pipes (Fig.1);
- check to ensure correct working of the rope ascent limit switch L (Fig.2);
- check to ensure correct working of the rope descent limit switch H (Fig.2);

NL

PT 2000

INBEDRIJFSTELLING EN GEBRUIK

Houd u, voor uw eigen veiligheid, voor met een werkcyclus aan te vangen, aan de verplichte controle-instructies:

- controleer of de buitenste structuur van de lier en van de vakwerkarm intact is.
- controleer of de hydraulische verbinding van de snelkoppelingen 1, 2, Afvoer en de staat van de slangen in orde zijn (Fig.1);
- controleer de werking van de eindaanslag kabel omlaag L (Fig.2);
- controleer de werking van de eindaanslag kabel omhoog H (Fig.2);

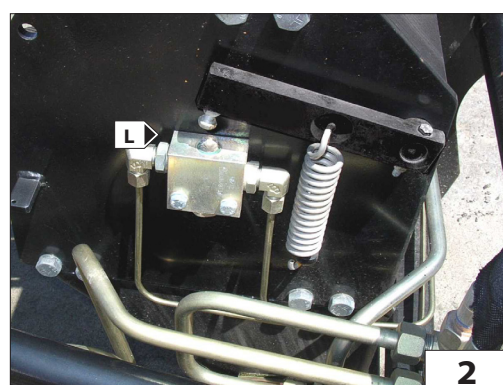
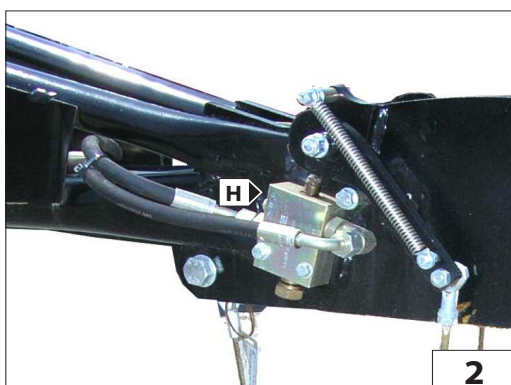
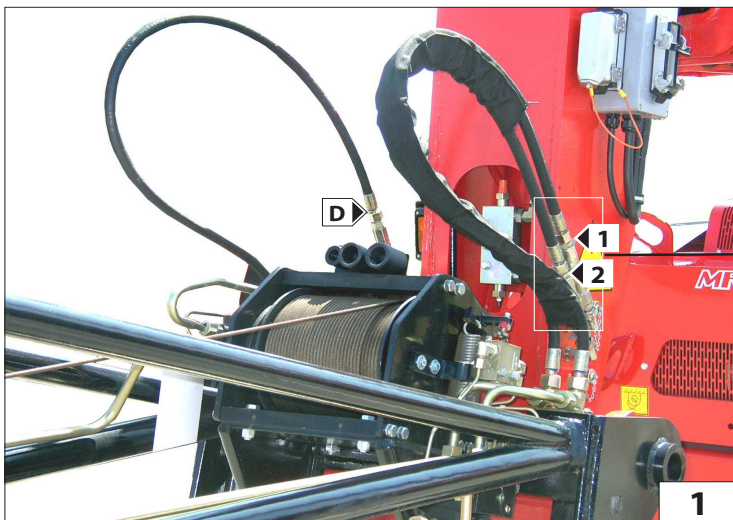

IT

- controllare lo stato della fune B (Fig.3) e il corretto avvolgimento sul tamburo A (Fig.3);
- controllare il corretto movimento rotazione delle pulegge di guida fune F1 (Fig.2 e 4);
- controllare lo stato del capocorda C (Fig.3);
- verificare l'integrità del bozzello F (Fig.4)
- verificare lo stato del gancio K (Fig.4): che non sia deformato, che ruoti liberamente e che la linguetta di sicurezza sia efficiente K1 (Fig.4);
- controllare l'aggancio del braccetto alla macchina operatrice J (Fig.5).

Dalla posizione di parcheggio è possibile sganciare il piede di appoggio e posizionarlo all'interno del braccetto per operare senza ulteriori ingombri J1 (Fig.5).

US

- check the condition of the rope B (Fig. 3) and that it is wound correctly on the drum A (Fig.3);
- check to ensure correct rotation movement of the rope guide pulley F1 (Fig. 2 and 4);
- check the condition of cable terminal C (Fig. 3);
- check the integrity of the block F (Fig.4)
- check the condition of the hook K (Fig. 4): to make sure it is not deformed, that it rotates freely and that the safety tab K1 (Fig. 4) is in working order;
- check the hook-up of the boom to the operating machine J (Fig. 5).

From the parking position it is possible to unhook the foot and position it inside the boom to operate without increasing the dimensions J1 (Fig.5).

NL

- controleer de staat van de kabel B (Fig.3) en de opwikkeling op de trommel A (Fig.3);
- controleer de draaibeweging van de kabelgeleidewielen F1 (Fig.2 en 4);
- controleer de staat van het kabeluiteinde C (Fig.3);
- controleer de staat van de takel F (Fig.4);
- controleer de staat van de haak K (Fig.4): of deze niet vervormd is, of hij vrij draait en of zijn veiligheidssluiting efficiënt is K1 (Fig.4);
- controleer de aankoppeling van de arm aan de machine J (Fig.5).

Vanuit de parkeerstand kan de steunpoot losgemaakt worden en binnenin de arm geplaatst worden om zonder onnodige ruimte innemende structuren te kunnen werken J1 (Fig.5).

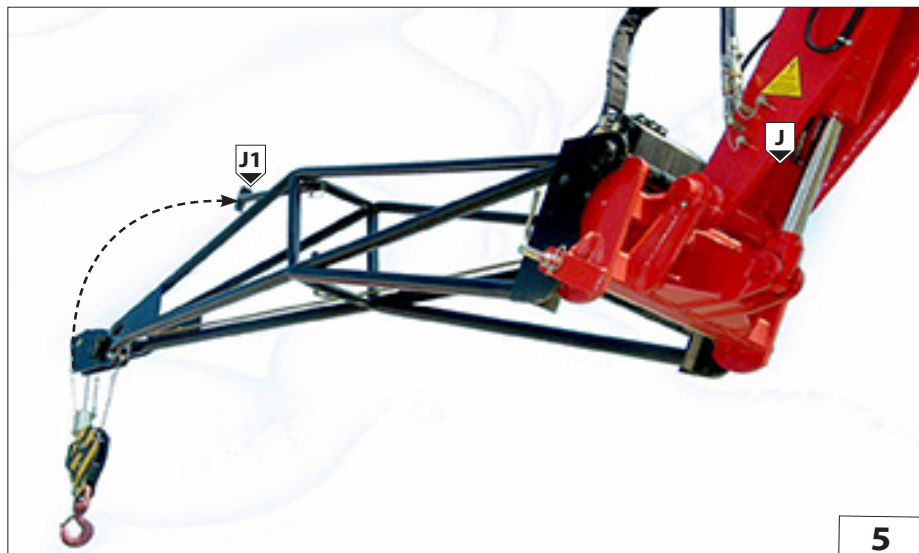
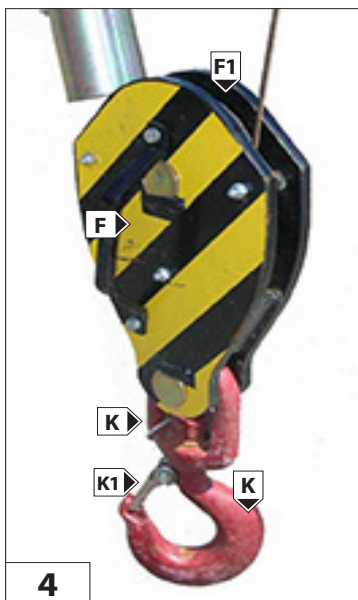
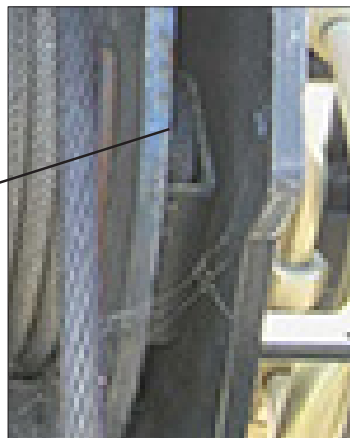
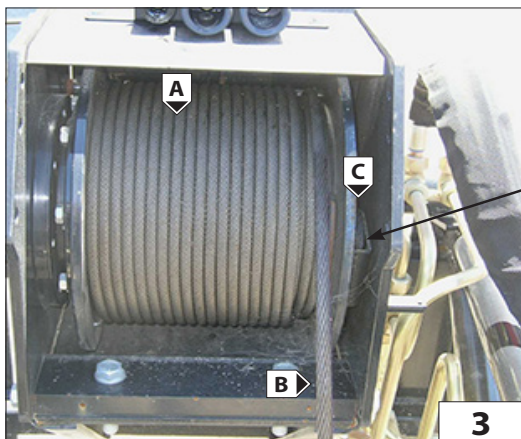



IT

MANUTENZIONE

- RIDUTTORE
- FUNE, PULEGGIA E CAPOCORDA
- BOZZELLO
- GANCIO
- FINE CORSA DISCESA FUNE
- FINE CORSA SALITA FUNE
- IMPIANTO IDRAULICO

US

MAINTENANCE

- REDUCTION GEAR
- ROPE, PULLEY AND CABLE TERMINAL
- PULLEY BLOCK
- HOOK
- ROPE DESCENT LIMIT SWITCH
- ROPE ASCENT LIMIT SWITCH
- HYDRAULIC SYSTEM

NL

ONDERHOUD

- REDUCTOR
- KABEL, KABELSCHIJF en KABELUI-
TEINDEN
- TAKEL
- HAAK
- EINDAANSLAG KABEL OMLAAG
- EINDAANSLAG KABEL OMHOOG
- HYDRAULISCH CIRCUIT



IT

RIDUTTORE

Una corretta lubrificazione consente un buon funzionamento e una lunga durata del riduttore.

Per accedere all'indicatore di livello o al tappo di rabbocco olio, occorre srotolare completamente la fune dal tamburo.

Controllare il livello dell'olio almeno una volta al mese B (Fig.6) e all'occorrenza rabboccare A (Fig.6) con olio dello stesso tipo di quello presente all'interno del riduttore (ISO VG 150).

Si consiglia l'utilizzo di olio per ingranaggi con additivazione EP con viscosità ISO VG, dipendente dalla temperatura di esercizio.

La prima sostituzione dell'olio deve essere effettuata dopo 100 ore di funzionamento, successivamente ogni 12 mesi o ogni 2000 ore di funzionamento.

Eseguire il cambio dell'olio con riduttore ancora caldo per facilitare un completo svuotamento.

Per scaricare l'olio, ruotare il tamburo del motore portando il tappo di rabbocco / scarico A (Fig.6a) verso il basso. Svitare il tappo A (Fig.6a) e scaricare completamente l'olio.

Ruotare il tamburo portando il foro di rabbocco/scarico verso l'alto A (Fig.6). Svitare il tappo di livello olio B (Fig.6); Rabboccare con olio nuovo e di tipo corretto fino a quando l'olio non fuoriesce da foro di livello B (Fig.6). (0,25 lt) Riavvitare i tappi e riavvolgere la fune.

US

REDUCTION GEAR

Correct lubrication allows proper working and longer life of the reduction gear.

To access the level indicator or oil topping up cap, the rope must be unwound completely from the drum.

Check the oil level at least once a month B (Fig.6) and if required, top up A (Fig.6) with oil of the same type as that present inside the reduction gear (ISO VG 150).

It is advisable to use oil for gears to which EP is added with viscosity ISO VG, depending on the operating temperature.

The first oil change must be after 100 hours of operation, then subsequently every 12 months or every 2000 hours of operation.

Change the oil with the reduction gear still hot to allow complete drainage.

To drain the oil, turn the engine drum so that the filler/drainage cap A (Fig. 6a) is facing downwards.

Unscrew cap A (Fig.6a) and drain out the oil completely.

Turn the drum to being the topping up/drainage hole facing upwards A (Fig.6).

Unscrew the oil level cap B (Fig.6).

Top up with fresh oil of the correct type until the oil flows out through the level hole B (Fig.6). (0.25 l).

Screw the cap back on and rewind the rope.

NL

REDUCTOR

Een correcte smering maakt een goede werking en een lange levensduur van de reductor mogelijk.

Om toegang te verkrijgen tot de oliepeilindicator of de oliebijvuldop, moet de kabel helemaal van de trommel gerold worden.

Controleer het oliepeil minstens eens per maand B (Fig.6) en indien nodig bijvullen A (Fig.6) met olie van hetzelfde soort als dat aanwezig is in de reductor (ISO VG 150).

Er wordt aangeraden olie voor tandwielen te gebruiken met additievering van EP met viscositeit ISO VG, afhankelijk van de bedrijfstemperatuur.

De eerste olieerversing moet na 100 werkuren plaatsvinden, daarna om de 12 maanden of om de 2000 werkuren.

Ververs de olie met nog warme reductor om een complete leging te vergemakkelijken.

Om de olie af te voeren, de trommel van de motor zodanig draaien dat de bijvul/aftapdop A (Fig.6a) naar beneden staat.

Draai de dop A (Fig.6a) los en laat alle olie weglopen.

Draai de trommel zodanig dat de bijvul/aftapopening naar boven staat A (Fig.6).

Draai de oliepeildop los B (Fig.6);

Vul bij met nieuwe olie van het juiste type totdat de olie door de oliepeilopening naar buiten komt B (Fig.6). (0,25 l)

Draai de doppen weer vast en wikkel de kabel weer op.

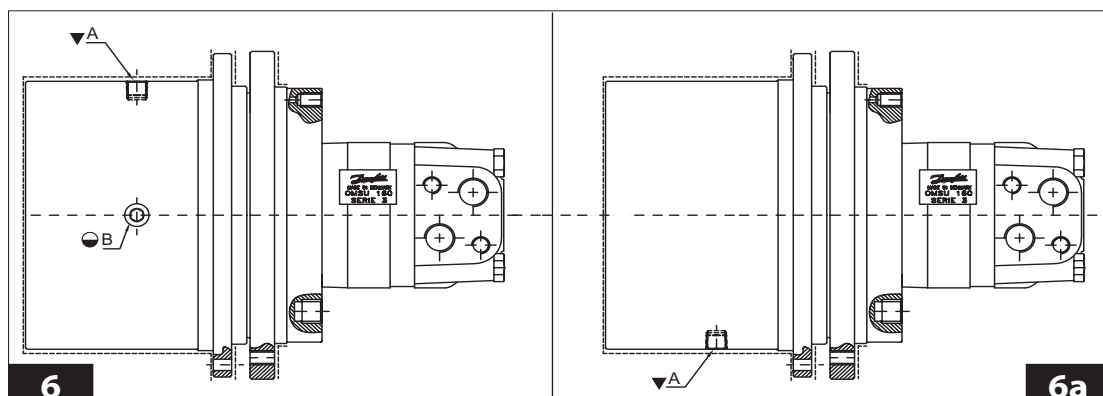
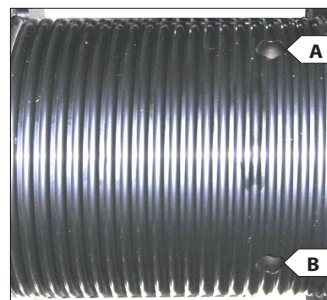

IT

FUNE, PULEGGIA e CAPOCORDA

Controllare giornalmente che la fune A (Fig.7) sia sempre in ottimo stato, che non ci siano filamenti rotti (Fig.7a) e che sia ben arrotolata sul tamburo B (Fig.7).

Altrimenti sostituirla con una nuova e dello stesso diametro e caratteristiche. Controllare la lubrificazione della fune, se necessita lubrificare con grasso industriale oppure olio sintetico anti-polvere.

Controllare e mantenere lubrificato i perni C (Fig.8) su cui ruotano le puleggie di guida D (Fig.8), che dovranno avere sempre un buono movimento di rotazione. Se necessita, lubrificare con grasso al sapone di litio il perno.

Assicurarsi dell'integrità dei capocorda E (Fig.9) e dei suoi morsetti fermafune.

US

ROPE, PULLEY AND CABLE TERMINAL

Check daily to make sure the rope A (Fig.7) is always in excellent condition, that it is not frayed (Fig.7a) and that it is wound perfectly around the drum B (Fig.7).

If necessary replace with a new rope having the same diameter and features. Check the lubrication of the rope, if necessary, lubricate with industrial grease or dust-proof synthetic oil.

Check and lubricate the pins C (Fig. 8) on which the guide pulleys D (Fig. 8) rotate and these must always rotate perfectly. If necessary, lubricate the pin with lithium soap grease.

Ensure the integrity of the cable terminals E (Fig.9) and the rope retainer clamps.

NL

KABEL, KABELSCHIJF en KABELUITEINDEN

Controleer dagelijks of de kabel A (Fig.7) in optimale staat verkeert, of er geen draden stuk zijn (Fig.7a) en of hij goed op de trommel gewonden is B (Fig.7).

Vervang hem anders door een nieuwe met dezelfde diameter en eigenschappen.

Controleer de smering van de kabel, indien nodig smeren met industrieel vet of synthetische olie tegen stof.

Controleer de pennen C (Fig.8) waarop de geleideschijven D (Fig.8) draaien en houd ze gesmeerd. Deze moet altijd een goede draaibeweging behouden. Indien nodig, de pen invetten met lithiumzeepvet.

Controleer de staat van de kabeluiteinden E (Fig.9) en de kabelklemmen.

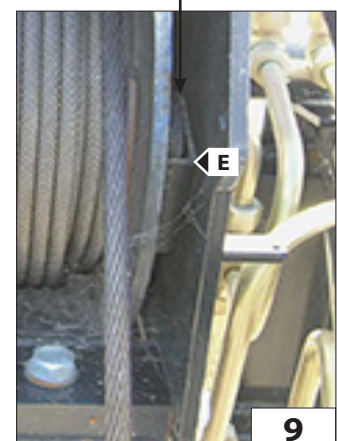
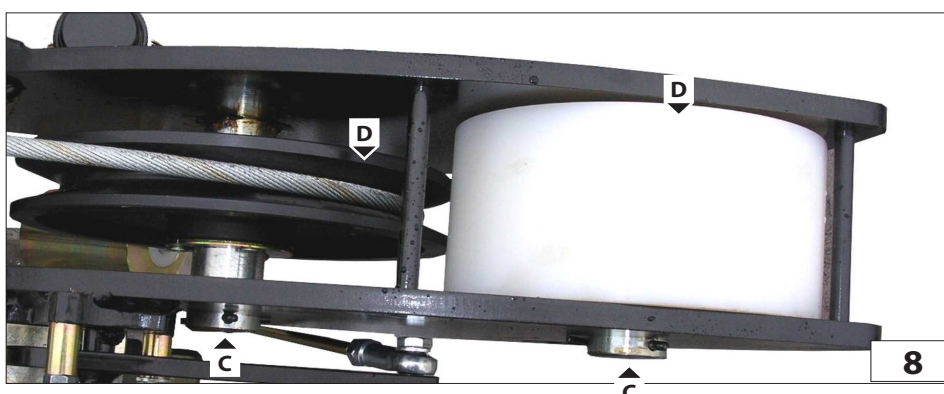
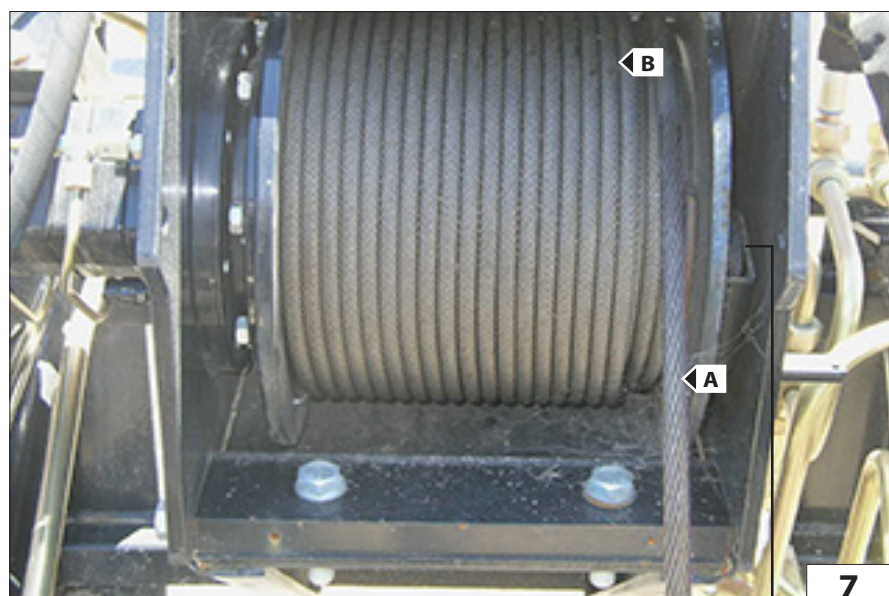
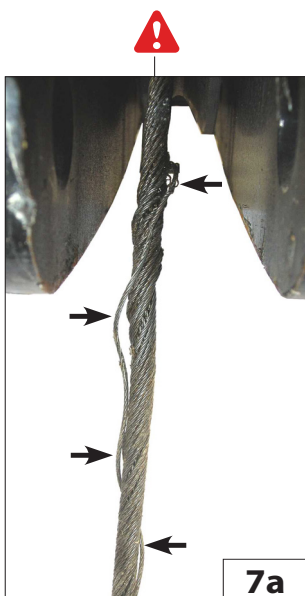

IT

BOZZELLO

Per una massima efficienza e sicurezza, mantenere intatta la struttura esterna F (Fig.10) e controllare che la puleggia G (Fig.10) ruoti correttamente sul suo perno G1 (Fig.10) .
Se necessità, lubrificare con grasso al sapone di litio il perno G1 (Fig.10).

GANCIO

Per una massima efficienza mantenere lubrificata la vite di rotazione del gancio N (Fig.10).
Senza carico sospeso, il gancio deve sempre ruotare liberamente e con la sola pressione della mano P (Fig.10). Controllare lo stato e l'efficienza della linguetta di sicurezza O (Fig.10).

US

PULLEY BLOCK

For maximum efficiency and safety, keep the external structure F (Fig.10) intact and check to make sure the pulley G (Fig.10) rotates correctly on its pin G1 (Fig.10) .
If necessary, lubricate the pin G1 (Fig. 10) with lithium soap grease.

HOOK

For maximum efficiency keep the hook rotation screw N (Fig. 10) lubricated.
Without a load hanging from it, the hook must always rotate freely when pushed slightly by hand P (Fig. 10).. Check the condition and efficiency of safety tab O (Fig. 10).

NL

TAKEL

Voor een maximale efficiëntie en veiligheid, de buitenste structuur intact houden F (Fig.10) en controleren of de kabelschijf G (Fig.10) goed op zijn pen draait G1 (Fig.10).
Indien nodig, de pen G1 (Fig.10) invetten met lithiumzeepvet.

HAAK

Voor een maximale efficiëntie de draaischroef van de haak N (Fig.10) gesmeerd houden.
Zonder hangende lading moet de haak altijd vrij kunnen draaien door er met de hand tegenaan te drukken P (Fig.10).
Controleer de staat en de efficiëntie van de veiligheidssluiting O (Fig.10).

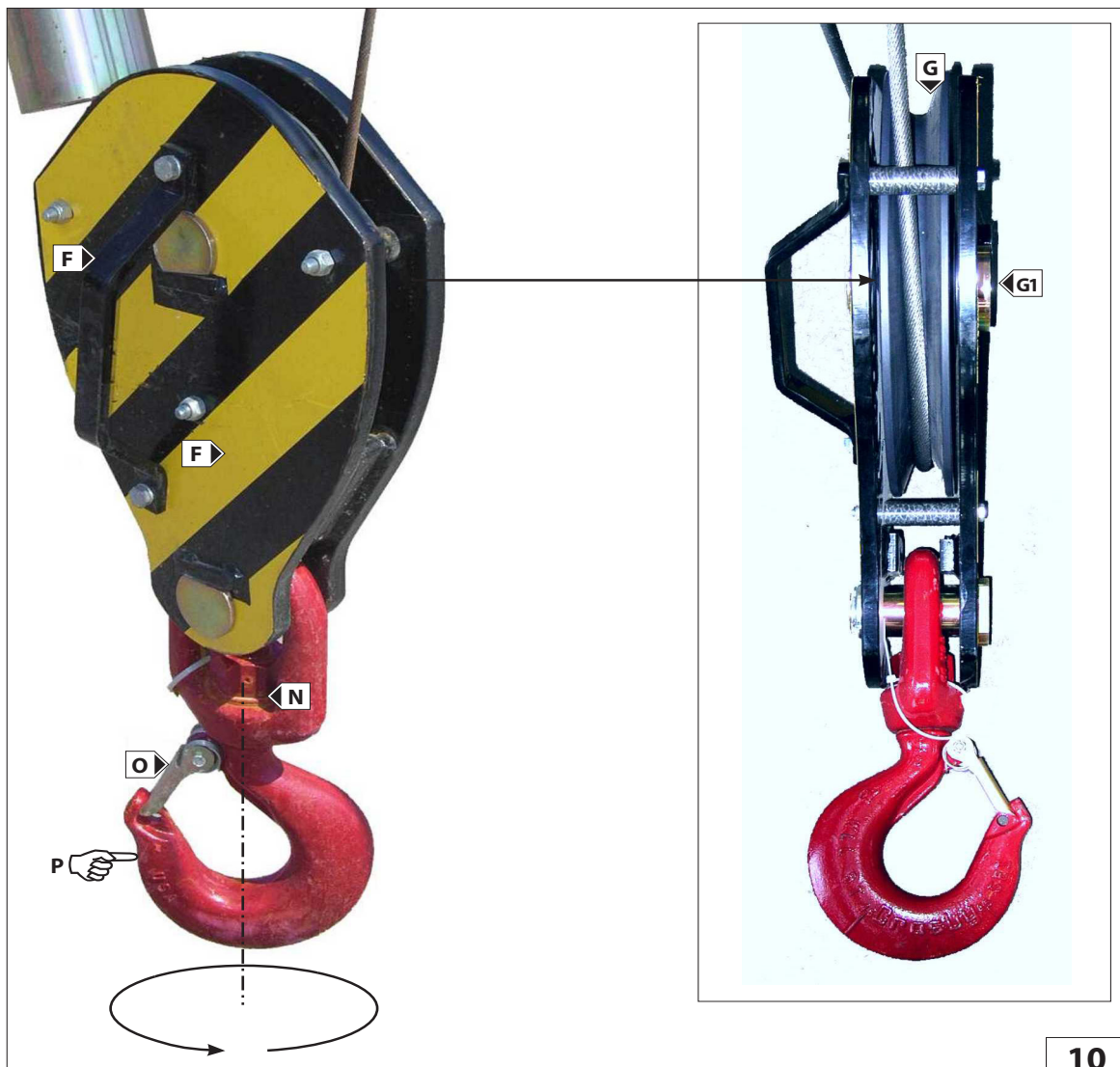

IT

FINE CORSA DISCESA FUNE (Fig.11)

Giornalmente per una massima efficienza mantenere sempre pulito il pistoncino e la valvola idraulica di sicurezza; controllare il serraggio dei raccordi e lo stato dei tubi. Inoltre verificare l'integrità del leveraggio di contatto finecorsa discesa e la tenuta della sua molla.

FINE CORSA SALITA FUNE

Giornalmente per una massima efficienza mantenere sempre pulito il pistoncino e la valvola idraulica di sicurezza; controllare il serraggio dei raccordi e lo stato dei tubi. Inoltre verificare l'integrità del leveraggio di contatto finecorsa salita e la tenuta della sua molla. (Fig.12)

IMPIANTO IDRAULICO (Fig.13)

Ispezionare giornalmente raccordi, valvole, tubi, per evitare eventuali perdite di olio che compromettano il rendimento e la durata dell'argano.

US

ROPE DESCENT LIMIT SWITCH (Fig. 11)

For maximum efficiency, check daily and keep the piston and hydraulic safety valve clean, check to make sure the connections are tightened properly and check the condition of the pipes. Also check the condition of the descent limit switch contact linkages and hold of its spring.

ROPE ASCENT LIMIT SWITCH

For maximum efficiency, check daily and keep the piston and hydraulic safety valve clean, check to make sure the connections are tightened properly and check the condition of the pipes. Also check the condition of the ascent limit switch contact linkages and hold of its spring. (Fig.12)

HYDRAULIC SYSTEM (Fig.13)

Check the connectors, valves, tubes daily to prevent oil leaks which could affect the performance and life of the winch.

NL

EINDAANSLAG KABEL OMLAAG (Fig.11)

Voor een maximale efficiëntie dagelijks altijd het zuigertje en het hydraulische veiligheidsventiel schoon houden; controleer of de verbindingen goed vast zitten en de staat van de leidingen. Controleer eveneens de staat van de hefbomen van de eindaanslag voor het dalen en zijn veer.

EINDAANSLAG KABEL OMHOOG

Voor een maximale efficiëntie dagelijks altijd het zuigertje en het hydraulische veiligheidsventiel schoon houden; controleer of de verbindingen goed vast zitten en de staat van de leidingen. Controleer eveneens de staat van de hefbomen van de eindaanslag voor het stijgen en zijn veer. (Fig.12)

HYDRAULISCHE INSTALLATIE (Fig.13)

Controleer dagelijks de verbindingstukken, kleppen en leidingen om eventuele olieklekken te voorkomen die het rendement en de levensduur van de lier zouden kunnen beïnvloeden.

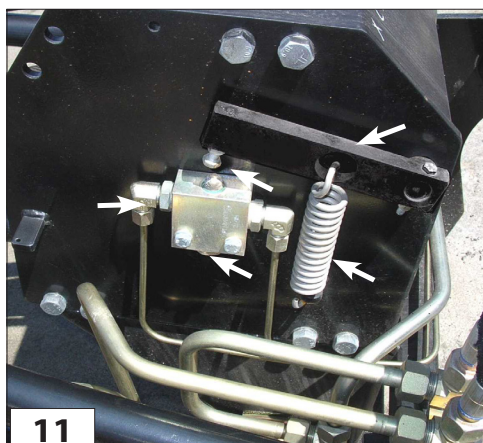
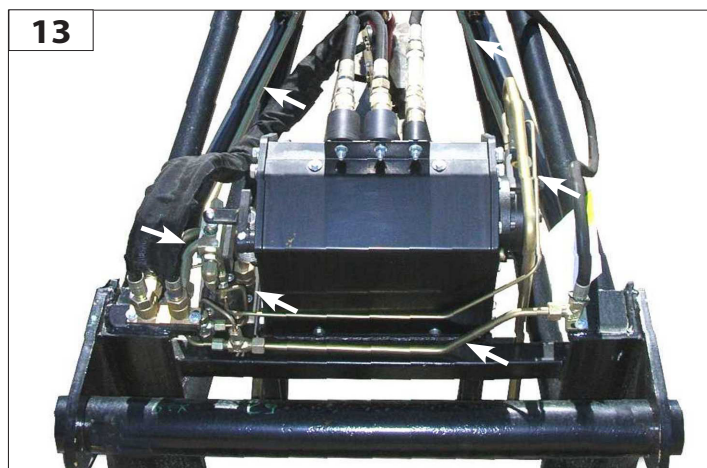

IT

US

NL

SCHEMA IDRAULICO

HYDRAULIC DIAGRAM

HYDRAULISCH SCHEMA

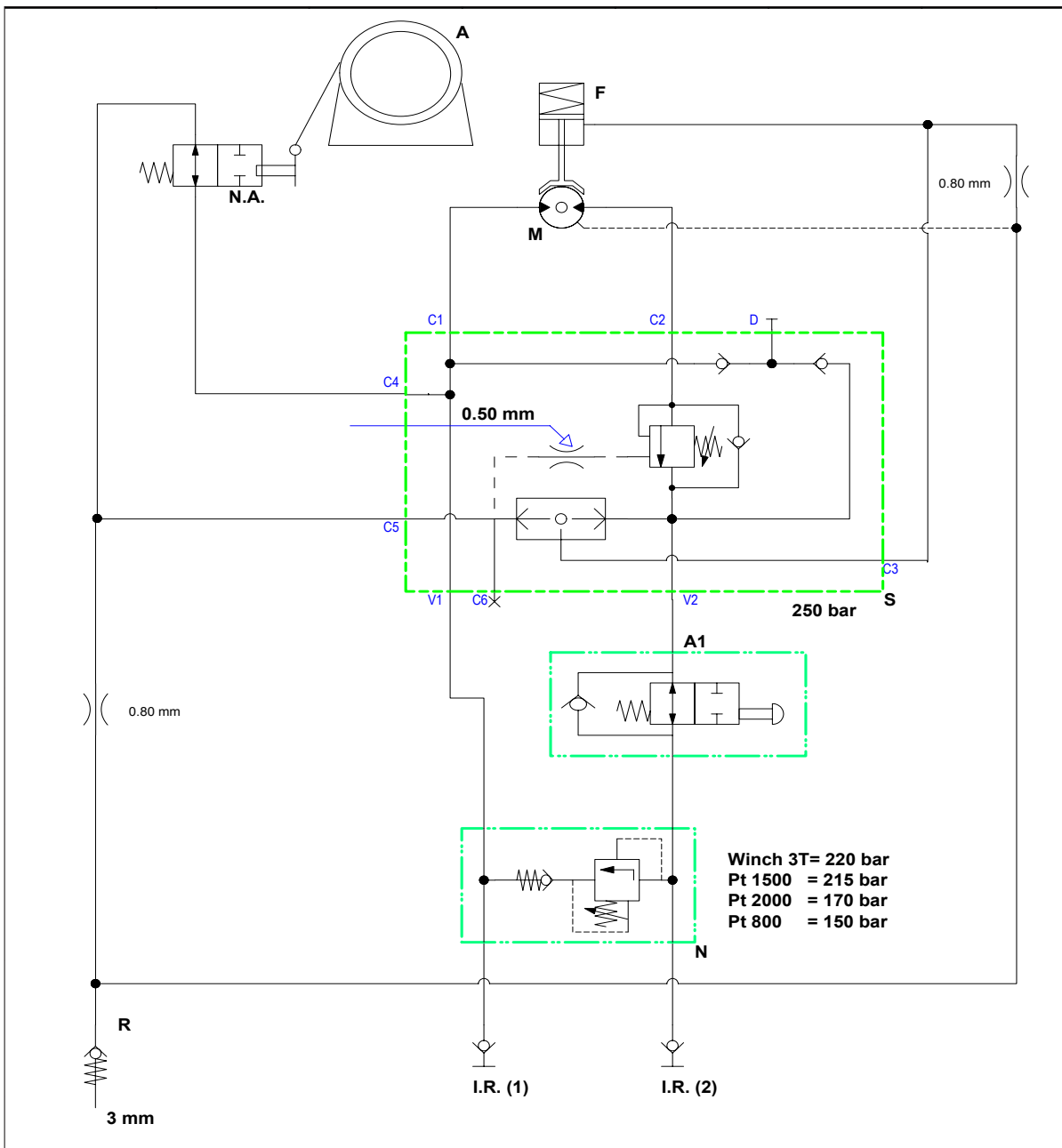

A = ARGANO
N.A. = MICRO MASSIMA DISCESA
R = SERBATOIO OLIO
I.R.1 = INNESTO RAPIDO
I.R.2 = INNESTO RAPIDO
A1 = MICRO MASSIMA SALITA
S = VALVOLA
N = VALVOLA MASSIMA PRESSIONE
M = MOTORE
F = FRENO

A = WINCH
N.A. = MAX. DESCENT MICRO SWITCH
R = OIL TANK
I.R.1 = QUICK-RELEASE COUPLING
I.R.2 = QUICK-RELEASE COUPLING
A1 = MAX. ASCENT MICRO SWITCH
S = VALVE
N = PRESSURE RELIEF VALVE
M = MOTOR
F = BRAKE

A = LIER
N.A. = MICRO MAXIMALE DALING
R = OLIE TANK
I.R.1 = SNELKOPPELING
I.R.2 = SNELKOPPELING
A1 = MICRO MAXIMALE STIJGING
S = VENTIEL
N = MAXIMUMDRUKVENTIEL
M = MOTOR
F = REM



Questa pagina è intenzionalmente vuota
This page is left blank intentionally
Deze pagina is opzettelijk leeg gelaten



PT 800

IT

Descrizione:

Traliccio sfilabile con argano: In posizione chiusa ha una lunghezza di 4mt e una portata di 1000Kg, in posizione sfilata ha una lunghezza di 7mt e una portata di 800Kg.

Caratteristiche:

- Tiro al 3° strato di 1000Kg.
- Velocità massima al 3° strato 46mt/min
- Il tiro è diretto
- La fune è di 37mt, diametro 10mm disposta su tre strati.
- Motore orbitale Sauer-Danfoss OMSU
- Riduttore epicicloidale con freno negativo a dischi in bagnod'olio
- Il tamburo è filettato e dotato di un rullo pressa fune in modo da assicurare sempre un corretto avvolgimento della fune
- Classificazione ISO 4301/1: T4, L2, M4

Sicurezza:

- Fine corsa discesa idraulico positivo
- Fine corsa salita idraulico positivo

US

Description:

Telescopic jib with winch. Closed: 4 m long and 1000 kg load.
Extended: 7 m long and 800 kg load.

Specifications:

- Line pull (3rdlayer): 1000 kg.
- Maximum speed (3rdlayer): 46 m/min
- Singleline pull
- 37 m long and 10 mm diameter cable arranged in three layers.
- Sauer-Danfoss OMSU orbital motor
- Planetary reduction gear featuring negative disk brake and oil bath
- The threaded drum is equipped with a cable-pressing roller to ensure the cable is always wound correctly
- ISO 4301/1 classification: T4, L2, M4

Safety features:

- Positive hydraulic descent limit stop
- Positive hydraulic ascent limit stop

NL

Beschrijving:

Uitschuifbaar rooster met lier: In gesloten positie bedraagt de lengte 4 m en het draagvermogen 1000 kg, in uitgeschoven positie bedraagt de lengte 7 m en het draagvermogen 800 kg.

Kenmerken:

- Trekkracht 3de laag 1000 kg.
- Maximalsnelheid 3de laag 46 m/min.
- Kabel enkel gebruikt.
- De kabel is 37 m, diameter 10 mm in drie lagen.
- Sauer-Danfoss OMSU orbitmotor
- Planetaire reductor met negatieve schijvenrem in oliebad
- De trommel is gegleufd en voorzien van een kabelandrukrol voor een altijd correcte opwikkeling van de kabel
- Classificatie ISO 4301/1: T4, L2, M4

Beschermingen:

- Positieve hydraulische eindaanslag daling
- Positieve hydraulische eindaanslag stijging





[kg] (lb)	[t] (t)	[kg] (lb)	[t] (t)	[mm] (in) x [m] (ft)	[m/min] (ft/min)	[bar] (psi)	[mm] (in)										[kg] (lb)
						P max											
•	◆						A	B	C	D	E	F	G	H	I	L	
800 (2204)	5 (5)	1000 (2204)	5 (5)	∅ 10 (0,3) x 37 (121)	46 (150)	150 (2175)	7290 (287)	4630 (182)	7170 (282)	4510 (177)	2580 (101)	1690 (66)	900 (35)	50 (1,9)	136 (5)	870 (34)	299 (659)

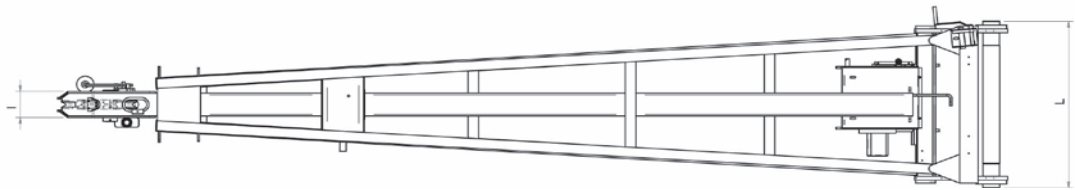
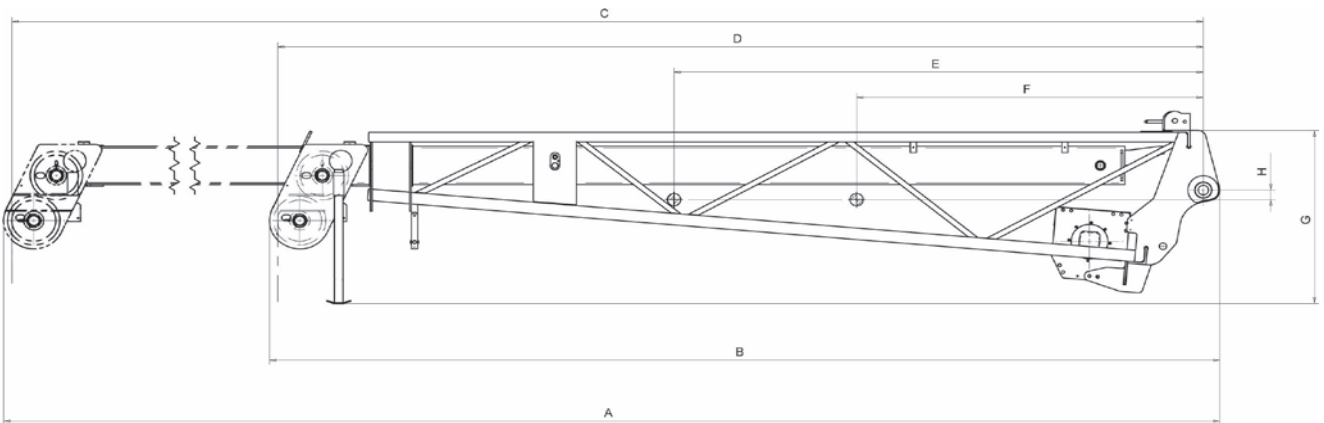

IT

PT 800

MESSA IN SERVIZIO E UTILIZZO

Per la vostra sicurezza, prima di iniziare un ciclo di lavoro, attenersi alle Istruzioni obbligatorie di verifica e controllo:

- verificare l'integrità della struttura esterna dell'argano e del braccetto tralicciato.
- verificare il corretto collegamento idraulico degli innesti rapidi 1, 2, Drenaggio e lo stato dei tubi flessibili (Fig.1);
- controllare il corretto funzionamento del fine corsa discesa fune H (Fig.2);
- controllare il corretto funzionamento del fine corsa salita fune L (Fig.2);

US

PT 800

COMMISSIONING AND USE

For your safety, before starting a work cycle, follow the compulsory instructions for inspection and checking:

- check the outer frame of the winch and the trestle arm.
- ensure correct hydraulic connection of quick-release couplings 1, 2, drainage and the condition of the hose pipes (Fig.1);
- check the correct working of the rope descent limit stop H (Fig.2);
- check the correct working of the rope lift limit stop L (Fig.2);

NL

PT 800

INBEDRIJFSTELLING EN GEBRUIK

Houd u, voor uw eigen veiligheid, voor met een werkcyclus aan te vangen, aan de verplichte controle-instructies:

- controleer of de buitenste structuur van de lier en van de vakwerkarm intact is.
- controleer of de hydraulische aansluiting van de snelkoppelingen 1, 2 correct is, Afvoer en de staat van de slangen in orde zijn (Fig.1);
- controleer de werking van de eindanslag kabel omlaag H (Fig.2);
- controleer de werking van de eindanslag kabel omhoog L (Fig.2);

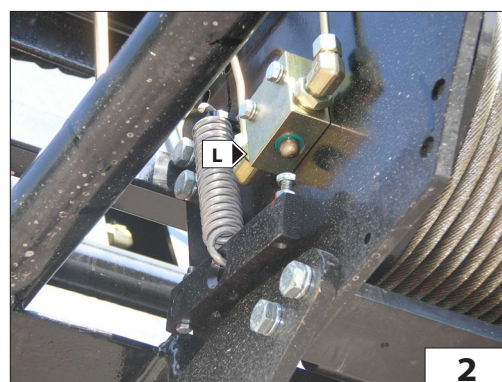
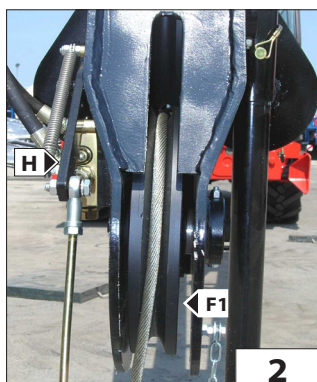
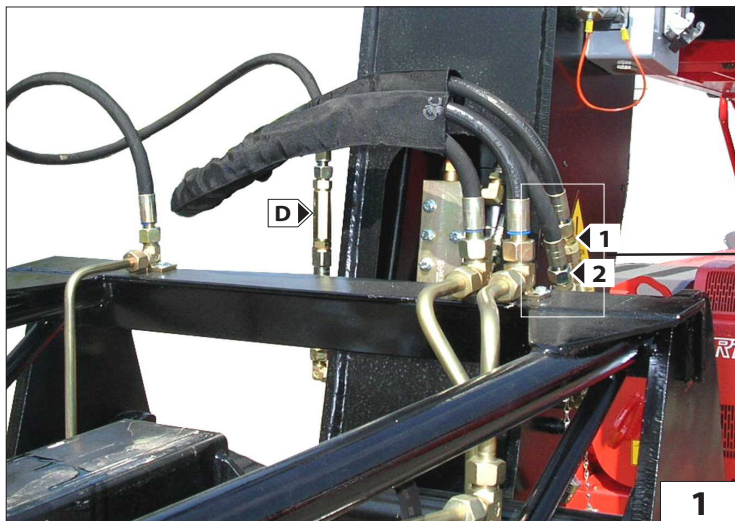

IT

- controllare lo stato della fune B (Fig.3) e il corretto avvolgimento sul tamburo A (Fig.3);
- controllare il corretto movimento rotazione delle puleggie di guida fune F1 (Fig.2);
- controllare lo stato del capocorda C (Fig.3);
- controllare che il grillo di collegamento fune e gancio sia ben avvitato K (Fig.4) e che i morsetti K1 (Fig.4) blocchino la fune.
- verificare lo stato del gancio: che non sia deformato, che ruoti liberamente e che la linguetta di sicurezza sia efficiente G (Fig.4);
- controllare l'aggancio del braccetto alla macchina operatrice J (Fig.5).

US

- check the condition of the rope B (Fig. 3) and that it is wound correctly on the drum A (Fig.3);
- check to ensure correct rotation movement of the rope guide pulley F1 (Fig. 2);
- check the condition of cable terminal C (Fig. 3);
- check to make sure the rope and hook connecting shackle is screwed in properly K (Fig.4) and that the terminals K1 (Fig.4) block the rope;
- check the condition of the hook: to make sure it is not deformed, that it rotates freely and that the safety tab G (Fig. 4) is in working order;
- check the hook-up of the boom to the operating machine J (Fig. 5).

NL

- controleer de staat van de kabel B (Fig.3) en de opwikkeling op de trommel A (Fig.3);
- controleer de draaibeweging van de kabelgeleidewielen F1 (Fig.2);
- controleer de staat van het kabeluiteinde C (Fig.3);
- controleer of de harpsluiting tussen de kabel en de haak K (Fig.4) goed vastgedraaid is en of de klemmen K1 (Fig.4) de kabel blokkeren.
- controleer de staat van de haak: of deze niet vervormd is, of hij vrij draait en of zijn veiligheidssluiting efficiënt is G (Fig.4);
- controleer de aankoppeling van de arm aan de machine J (Fig.5).

Dalla posizione di parcheggio è possibile sganciare il piede di appoggio e posizionarlo all'interno del braccetto per operare senza ulteriori ingombri J1 (Fig.5).

From the parking position it is possible to unhook the foot and position it inside the boom to operate without increasing the dimensions J1 (Fig.5).

Vanuit de parkeerstand kan de steunpoot losgemaakt worden en binnenin de arm geplaatst worden om zonder onnodige ruimte innemende structuren te kunnen werken J1 (Fig.5).

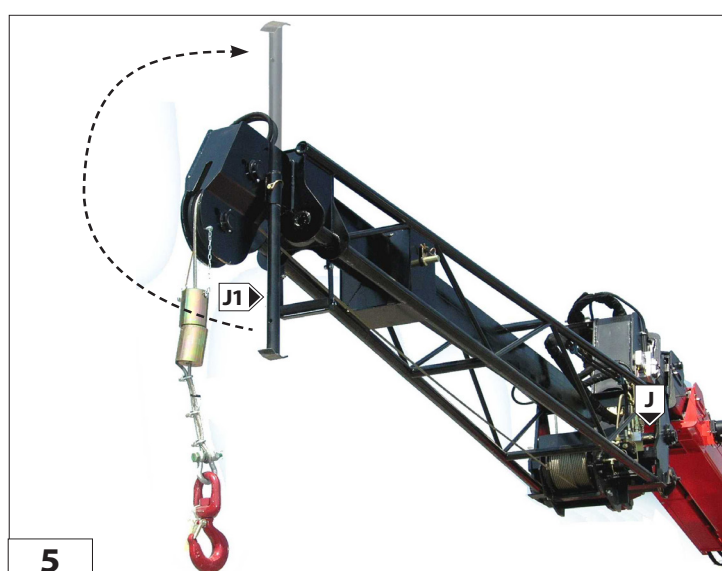
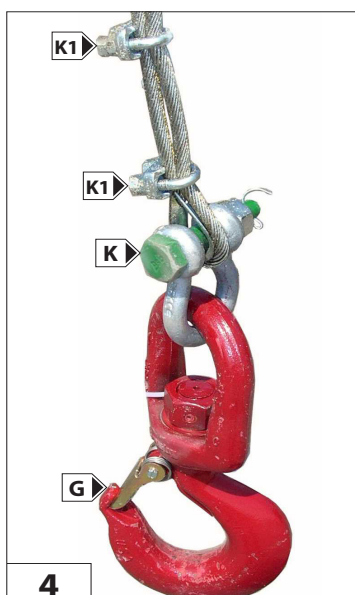
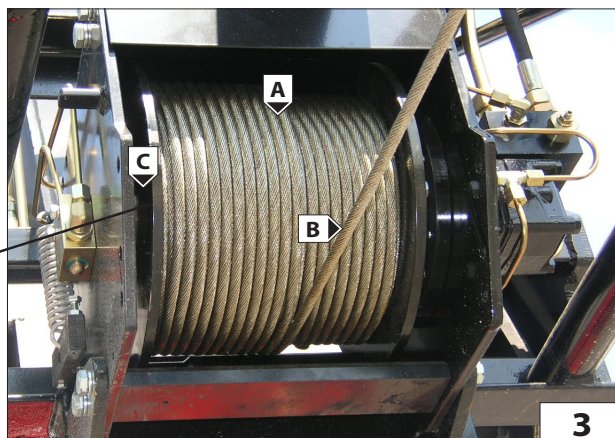
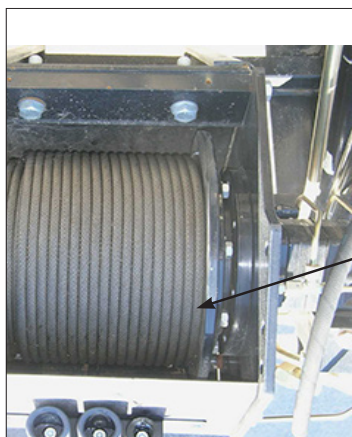



IT

MANUTENZIONE

- RIDUTTORE
- FUNE, PULEGGIA E CAPOCORDA
- BOZZELLO
- GANCIO
- FINE CORSA DISCESA FUNE
- FINE CORSA SALITA FUNE
- IMPIANTO IDRAULICO

US

MAINTENANCE

- REDUCTION GEAR
- ROPE, PULLEY AND CABLE TERMINAL
- PULLEY BLOCK
- HOOK
- ROPE DESCENT LIMIT SWITCH
- ROPE ASCENT LIMIT SWITCH
- HYDRAULIC SYSTEM

NL

ONDERHOUD

- REDUCTOR
- KABEL, KABELSCHIJF en KABELUITEINDEN
- TAKEL
- HAAK
- EINDAANSLAG KABEL OMLAAG
- EINDAANSLAG KABEL OMHOOG
- HYDRAULISCH CIRCUIT



IT

RIDUTTORE

Una corretta lubrificazione consente un buon funzionamento e una lunga durata del riduttore.

Per accedere all'indicatore di livello o al tappo di rabbocco olio, occorre srotolare completamente la fune dal tamburo.

Controllare il livello dell'olio almeno una volta al mese B (Fig.6) e all'occorrenza rabboccare A (Fig.6) con olio dello stesso tipo di quello presente all'interno del riduttore (ISO VG 150).

Si consiglia l'utilizzo di olio per ingranaggi con additivazione EP con viscosità ISO VG, dipendente dalla temperatura di esercizio.

La prima sostituzione dell'olio deve essere effettuata dopo 100 ore di funzionamento, successivamente ogni 12 mesi o ogni 2000 ore di funzionamento.

Eseguire il cambio dell'olio con riduttore ancora caldo per facilitare un completo svuotamento.

Per scaricare l'olio, ruotare il tamburo del motore portando il tappo di rabbocco / scarico A (Fig.6a) verso il basso. Svitare il tappo A (Fig.6a) e scaricare completamente l'olio.

Ruotare il tamburo portando il foro di rabbocco/scarico verso l'alto A (Fig.6). Svitare il tappo di livello olio B (Fig.6); Rabboccare con olio nuovo e di tipo corretto fino a quando l'olio non fuoriesce da foro di livello B (Fig.6). (0,25 lt) Riavvitare i tappi e riavvolgere la fune.

US

REDUCTION GEAR

Correct lubrication allows proper working and longer life of the reduction gear.

To access the level indicator or oil topping up cap, the rope must be unwound completely from the drum.

Check the oil level at least once a month B (Fig.6) and if required, top up A (Fig.6) with oil of the same type as that present inside the reduction gear (ISO VG 150).

It is advisable to use oil for gears to which EP is added with viscosity ISO VG, depending on the operating temperature.

The first oil change must be after 100 hours of operation, then subsequently every 12 months or every 2000 hours of operation.

Change the oil with the reduction gear still hot to allow complete drainage.

To drain the oil, turn the engine drum so that the filler/drainage cap A (Fig. 6a) is facing downwards.

Unscrew cap A (Fig.6a) and drain out the oil completely.

Turn the drum to being the topping up/drainage hole facing upwards A (Fig.6).

Unscrew the oil level cap B (Fig.6).

Top up with fresh oil of the correct type until the oil flows out through the level hole B (Fig.6).(0.25 l).

Screw the cap back on and rewind the rope.

NL

REDUCTOR

Een correcte smering maakt een goede werking en een lange levensduur van de reductor mogelijk.

Om toegang te verkrijgen tot de oliepeilindicator of de oliebijvuldop, moet de kabel helemaal van de trommel gerold worden.

Controleer het oliepeil minstens eens per maand B (Fig.6) en indien nodig bijvullen A (Fig.6) met olie van hetzelfde soort als dat aanwezig is in de reductor (ISO VG 150).

Er wordt aangeraden olie voor tandwielen te gebruiken met additievering van EP met viscositeit ISO VG, afhankelijk van de bedrijfstemperatuur.

De eerste olieerversing moet na 100 werkuren plaatsvinden, daarna om de 12 maanden of om de 2000 werkuren.

Ververs de olie met nog warme reductor om een complete leging te vergemakkelijken.

Om de olie af te voeren, de trommel van de motor zodanig draaien dat de bijvul/aftapdop A (Fig.6a) naar beneden staat.

Draai de dop A (Fig.6a) los en laat alle olie weglopen.

Draai de trommel zodanig dat de bijvul/aftapopening naar boven staat A (Fig.6).

Draai de oliepeildop los B (Fig.6);

Vul bij met nieuwe olie van het juiste type totdat de olie door de oliepeilopening naar buiten komt B (Fig.6). (0,25 l)

Draai de doppen weer vast en wikkel de kabel weer op.

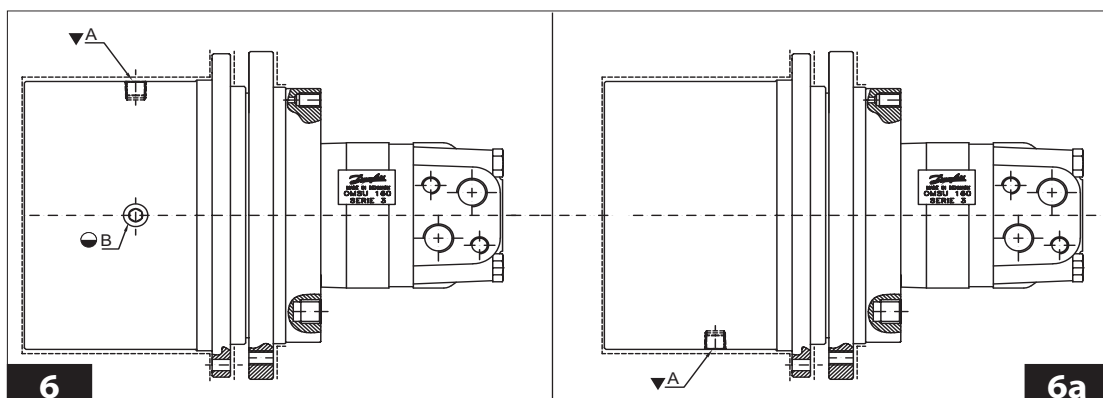
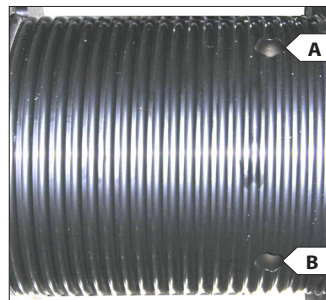

IT

FUNE, PULEGGIA e CAPOCORDA

Controllare giornalmente che la fune A (Fig.7) sia sempre in ottimo stato, che non ci siano filamenti rotti (Fig.7a) e che sia ben arrotolata sul tamburo B (Fig.7).

Altrimenti sostituirla con una nuova e dello stesso diametro e caratteristiche. Controllare la lubrificazione della fune, se necessita lubrificare con grasso industriale oppure olio sintetico anti-polvere.

Controllare e mantenere lubrificato i perni C (Fig.8) su cui ruotano le puleggie di guida D (Fig.8), che dovranno avere sempre un buono movimento di rotazione. Se necessita, lubrificare con grasso al sapone di litio il perno.

Assicurarsi dell'integrità dei capocorda E (Fig.9) e dei suoi morsetti fermafune.

US

ROPE, PULLEY AND CABLE TERMINAL

Check daily to make sure the rope A (Fig.7) is always in excellent condition, that it is not frayed (Fig.7a) and that it is wound perfectly around the drum B (Fig.7).

If necessary replace with a new rope having the same diameter and features. Check the lubrication of the rope, if necessary, lubricate with industrial grease or dust-proof synthetic oil.

Check and lubricate the pins C (Fig. 8) on which the guide pulleys D (Fig. 8) rotate and these must always rotate perfectly. If necessary, lubricate the pin with lithium soap grease.

Ensure the integrity of the cable terminals E (Fig.9) and the rope retainer clamps.

NL

KABEL, KABELSCHIJF en KABELUITEINDEN

Controleer dagelijks of de kabel A (Fig.7) in optimale staat verkeert, of er geen draden stuk zijn (Fig.7a) en of hij goed op de trommel gewonden is B (Fig.7).

Vervang hem anders door een nieuwe met dezelfde diameter en eigenschappen.

Controleer de smering van de kabel, indien nodig smeren met industrieel vet of synthetische olie tegen stof.

Controleer de pennen C (Fig.8) waarop de geleideschijven D (Fig.8) draaien en houd ze gesmeerd. Deze moet altijd een goede draaibeweging behouden. Indien nodig, de pen invetten met lithiumzeepvet.

Controleer de staat van de kabeluiteinden E (Fig.9) en de kabelklemmen.

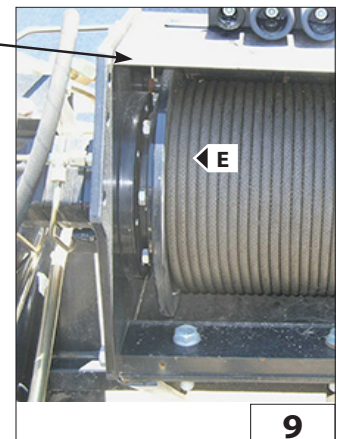
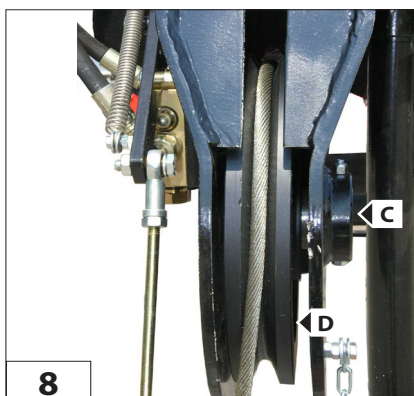
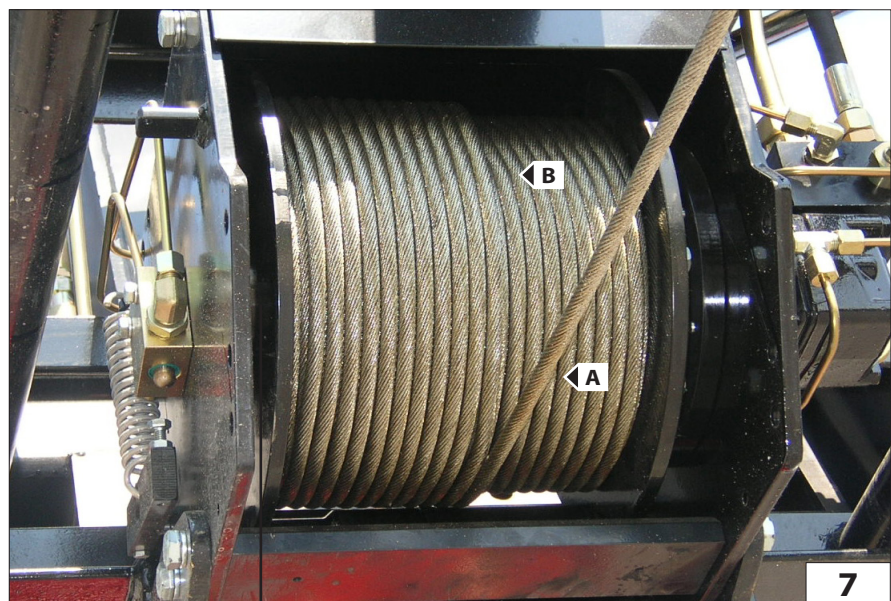
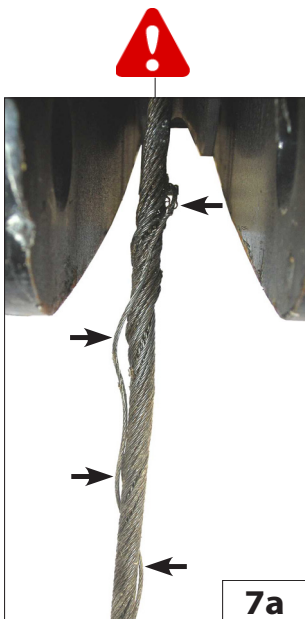

IT

GRILLO E MORSETTI

È importante verificare l'integrità e il serraggio delle viti dei morsetti F (Fig.10) e del bullone del grillo G (Fig.10) una volta alla settimana.

GANCIO

Per una massima efficienza mantenere lubrificata la vite di rotazione del gancio N (Fig.10).

Senza carico sospeso, il gancio deve sempre ruotare liberamente e con la sola pressione della mano P (Fig.10). Controllare lo stato e l'efficienza della linguetta di sicurezza O (Fig.10).

US

SHACKLE AND TERMINALS

Check the condition and tightening of the screws of terminals F (Fig. 10) and the bolt of shackle G (Fig. 10) once a week.

HOOK

For maximum efficiency keep the hook rotation screw N (Fig. 10) lubricated. Without a load hanging from it, the hook must always rotate freely when pushed slightly by hand P (Fig. 10).. Check the condition and efficiency of safety tab O (Fig. 10).

NL

HARPSLUITING EN KLEMMEN

Het is van belang de staat en de aandraaiing van de schroeven van de klemmen F (Fig.10) en van de bout van de harpsluiting G (Fig.10) eens in de week na te kijken.

HAAK

Voor een maximale efficiëntie de draaischroef van de haak N (Fig.10) gesmeerd houden.

Zonder hangende lading moet de haak altijd vrij kunnen draaien door er met de hand tegenaan te drukken P (Fig.10). Controleer de staat en de efficiëntie van de veiligheidssluiting O (Fig.10).

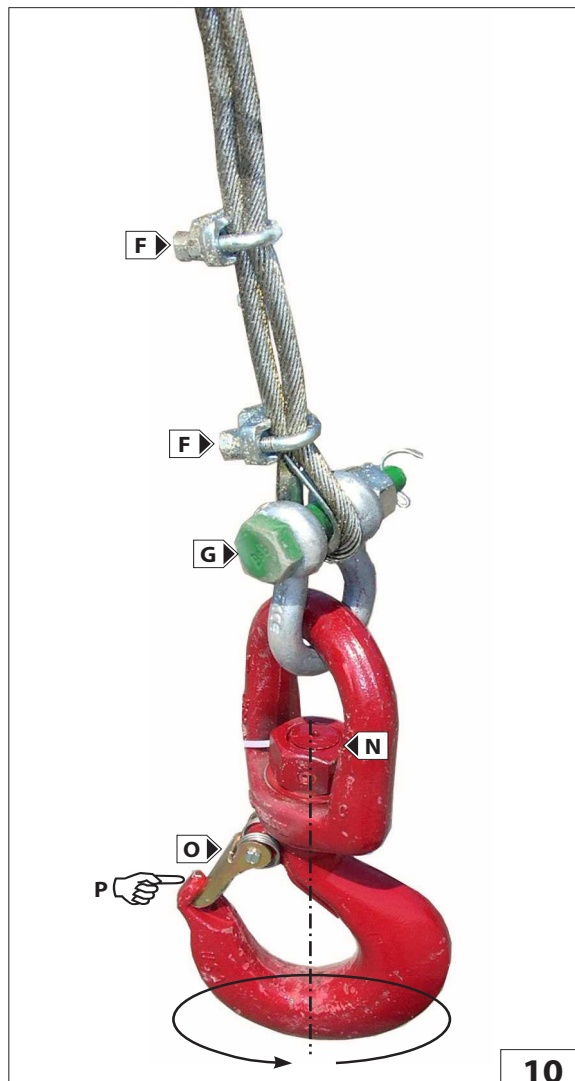

IT

FINE CORSA DISCESA FUNE (Fig.11)

Giornalmente per una massima efficienza mantenere sempre pulito il pistoncino e la valvola idraulica di sicurezza; controllare il serraggio dei raccordi e lo stato dei tubi. Inoltre verificare l'integrità del leveraggio di contatto fincorsa discesa e la tenuta della sua molla.

FINE CORSA SALITA FUNE

Giornalmente per una massima efficienza mantenere sempre pulito il pistoncino e la valvola idraulica di sicurezza; controllare il serraggio dei raccordi e lo stato dei tubi. Inoltre verificare l'integrità del leveraggio di contatto fincorsa salita e la tenuta della sua molla. (Fig.12)

IMPIANTO IDRAULICO (Fig.13)

Ispezionare giornalmente raccordi, valvole, tubi, per evitare eventuali perdite di olio che compromettano il rendimento e la durata dell'argano.

US

ROPE DESCENT LIMIT SWITCH (Fig. 11)

For maximum efficiency, check daily and keep the piston and hydraulic safety valve clean, check to make sure the connections are tightened properly and check the condition of the pipes. Also check the condition of the descent limit switch contact linkages and hold of its spring.

ROPE ASCENT LIMIT SWITCH

For maximum efficiency, check daily and keep the piston and hydraulic safety valve clean, check to make sure the connections are tightened properly and check the condition of the pipes. Also check the condition of the ascent limit switch contact linkages and hold of its spring. (Fig.12)

HYDRAULIC SYSTEM (Fig.13)

Check the connectors, valves, tubes daily to prevent oil leaks which could affect the performance and life of the winch.

NL

EINDAANSLAG KABEL OMLAAG (Fig.11)

Voor een maximale efficiëntie dagelijks altijd het zuigertje en het hydraulische veiligheidsventiel schoon houden; controleer of de verbindingen goed vast zitten en de staat van de leidingen. Controleer eveneens de staat van de hefboomen van de eindaanslag voor het dalen en zijn veer.

EINDAANSLAG KABEL OMHOOG

Voor een maximale efficiëntie dagelijks altijd het zuigertje en het hydraulische veiligheidsventiel schoon houden; controleer of de verbindingen goed vast zitten en de staat van de leidingen. Controleer eveneens de staat van de hefboomen van de eindaanslag voor het stijgen en zijn veer. (Fig.12)

HYDRAULISCHE INSTALLATIE (Fig.13)

Controleer dagelijks de verbindingstukken, kleppen en leidingen om eventuele olielekken te voorkomen die het rendement en de levensduur van de lier zouden kunnen beïnvloeden.

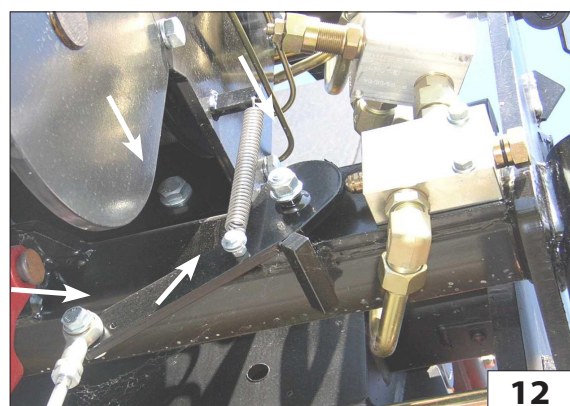
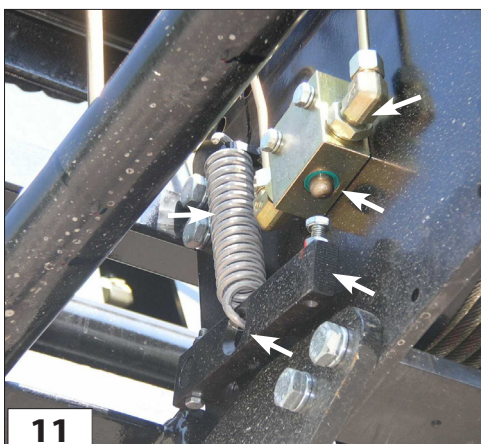
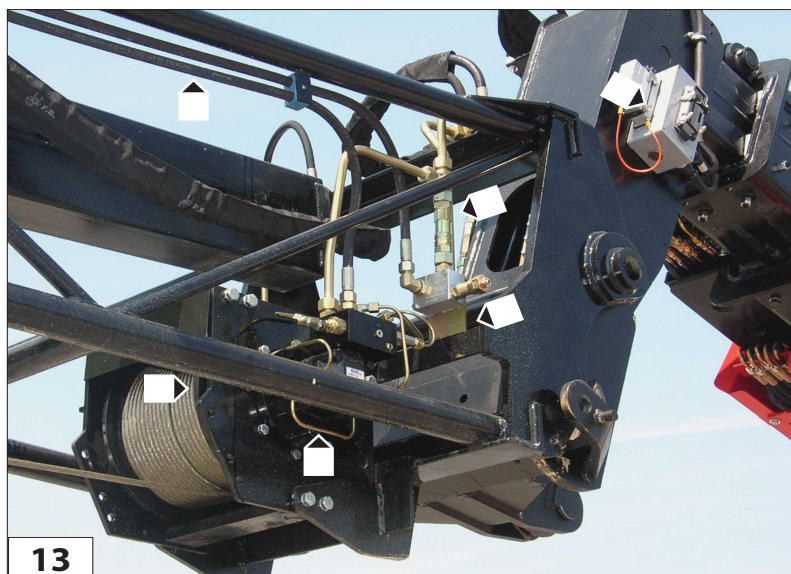



IT

US

NL

SCHEMA IDRAULICO

HYDRAULIC DIAGRAM

HYDRAULISCH SCHEMA

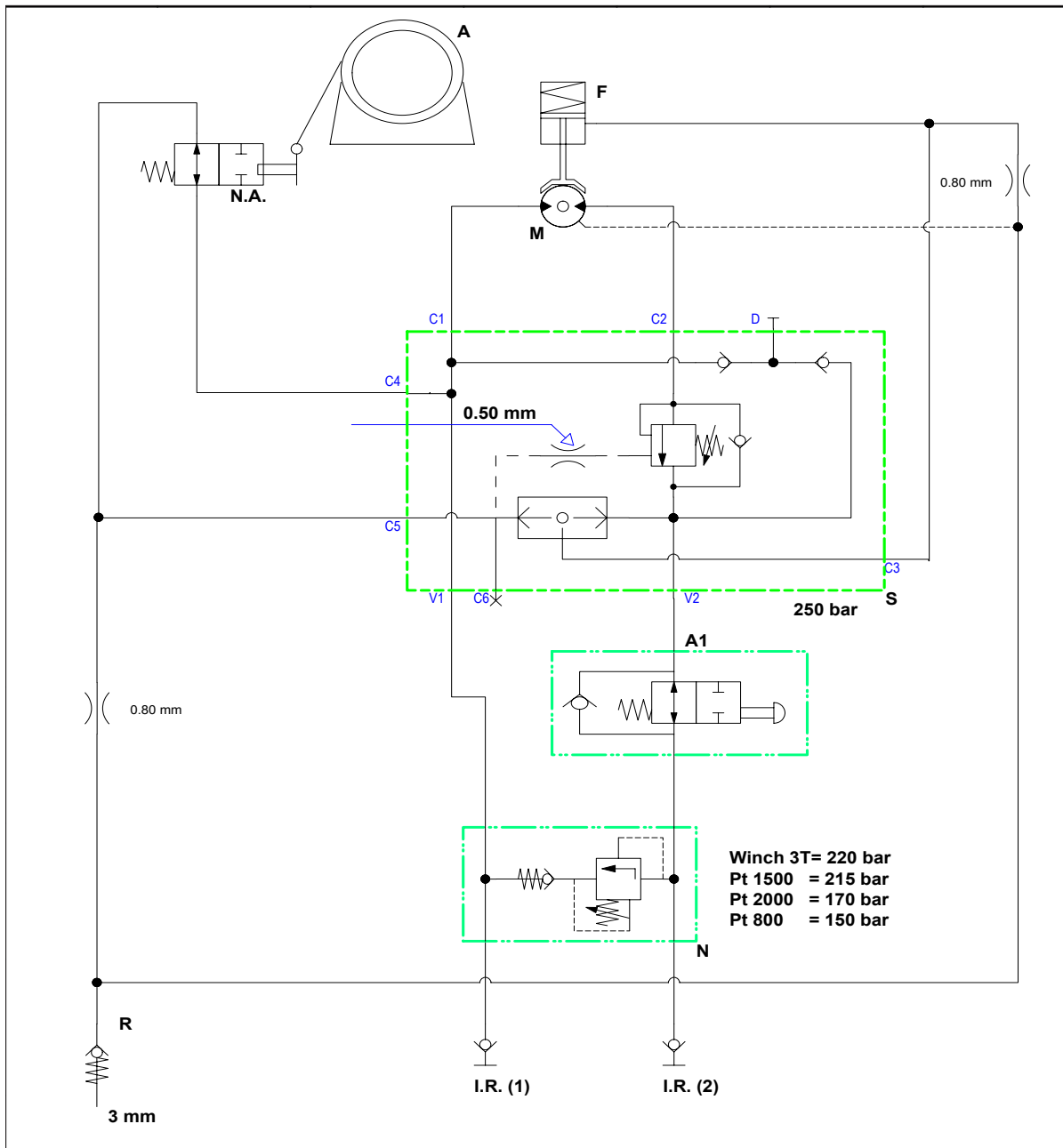

A = ARGANO
N.A. = MICRO MASSIMA DISCESA
R = SERBATOIO OLIO
I.R.1 = INNESTO RAPIDO
I.R.2 = INNESTO RAPIDO
A1 = MICRO MASSIMA SALITA
S = VALVOLA
N = VALVOLA MASSIMA PRESSIONE
M = MOTORE
F = FRENO

A = WINCH
N.A. = MAX. DESCENT MICRO SWITCH
R = OIL TANK
I.R.1 = QUICK-RELEASE COUPLING
I.R.2 = QUICK-RELEASE COUPLING
A1 = MAX. ASCENT MICRO SWITCH
S = VALVE
N = PRESSURE RELIEF VALVE
M = MOTOR
F = BRAKE

A = LIER
N.A. = MICRO MAXIMALE DALING
R = OLJETANK
I.R.1 = SNELKOPPELING
I.R.2 = SNELKOPPELING
A1 = MICRO MAXIMALE STIJING
S = VENTIEL
N = MAXIMUMDRUKVENTIEL
M = MOTOR
F = REM



Questa pagina è intenzionalmente vuota
This page is left blank intentionally
Deze pagina is opzettelijk leeg gelaten



PC 30

IT

Descrizione:

Braccetto lungo 0,50 m con una portata di 3000Kg.

US

Description:

0.50 m long arm with a capacity of 3000 kg.

NL

Beschrijving:

0,50 m lange arm met een draagvermogen van 3000 kg.

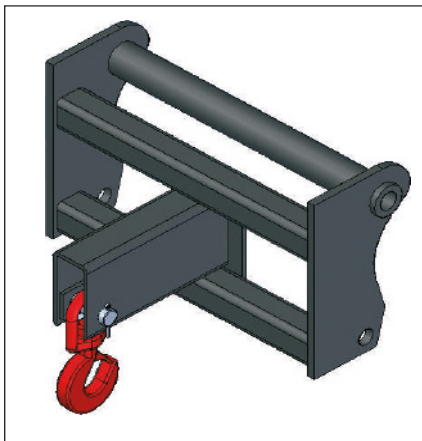



[kg] (lb)	[t] (t)	[mm] (in)									[kg] (lb)
3000 (6614)	5 (5)	A 740 (29)	B 598 (23)	C 470 (18)	D 354 (14)	E 153 (6)	F 156 (6,1)	G 200 (7,8)	H 462 (18)	I 484 (19)	120 (265)

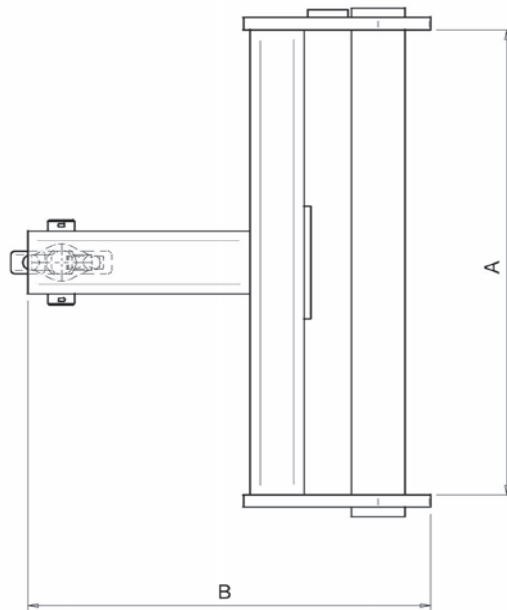
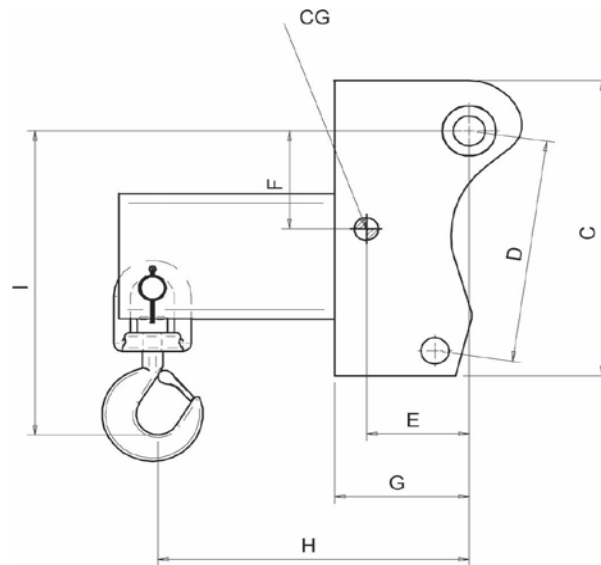



Questa pagina è intenzionalmente vuota
This page is left blank intentionally
Deze pagina is opzettelijk leeg gelaten



PC 40

IT

Descrizione:

Braccetto lungo 0,50 m con una portata di 4000Kg.

US

Description:

0.50 m long arm with a capacity of 4000 kg.



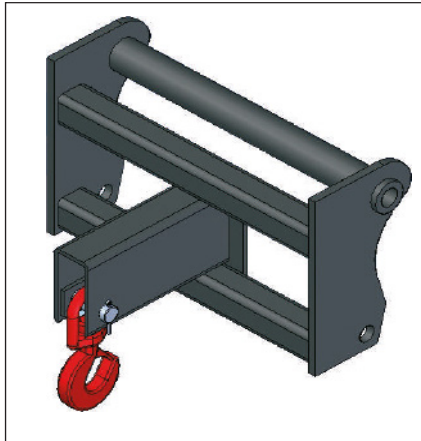

NL

Beschrijving:

0,50 m lange arm met een draagvermogen van 4000 kg.





[kg] (lb)	[t] (t)	[mm] (in)									[kg] (lb)
											
4000 (8818)	5 (5)	A 740 (29)	B 598 (23)	C 470 (18)	D 354 (14)	E 153 (6)	F 156 (6,1)	G 200 (7,8)	H 462 (18)	I 484 (19)	120 (265)

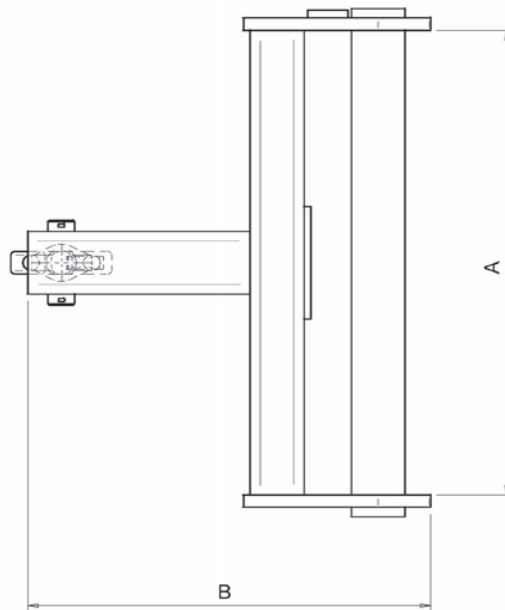
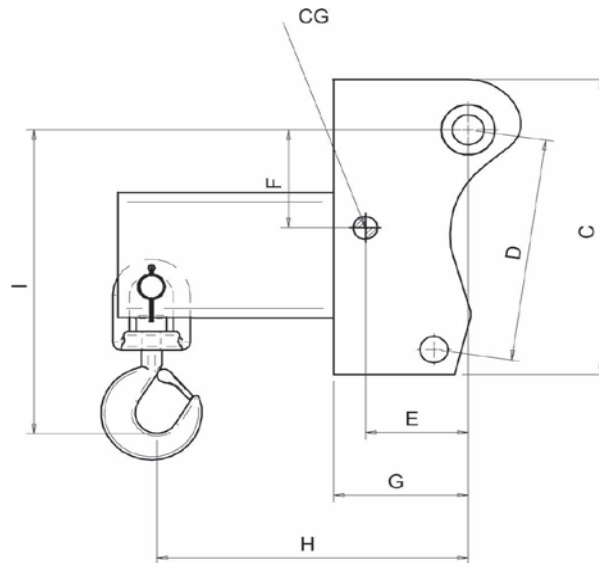



Questa pagina è intenzionalmente vuota
This page is left blank intentionally
Deze pagina is opzettelijk leeg gelaten



PC 40

IT

Descrizione:

Braccetto lungo 0,50 m con una portata di 4000Kg.

US

Description:

0.50 m long arm with a capacity of 4000 kg.

NL

Beschrijving:

0,50 m lange arm met een draagvermogen van 4000 kg.

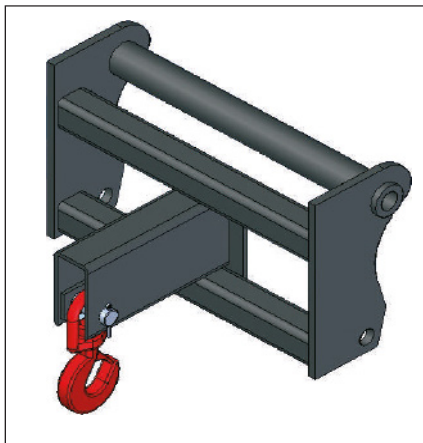



[kg] (lb)	[t] (t)	[mm] (in)									[kg] (lb)
4000 (8818)	4 (4)	A 740 (29)	B 598 (23)	C 470 (18)	D 354 (14)	E 153 (6)	F 156 (6,1)	G 200 (7,8)	H 462 (18)	I 484 (19)	120 (265)

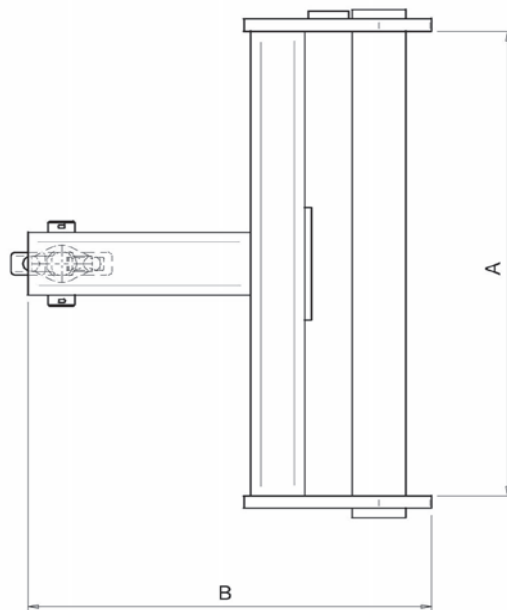
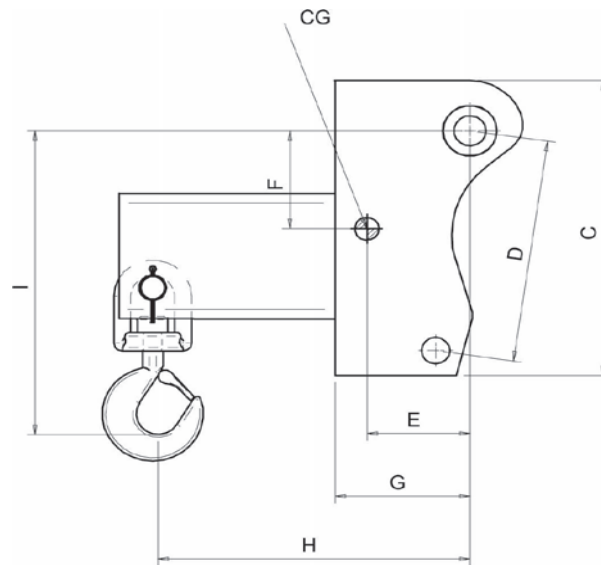



Questa pagina è intenzionalmente vuota
This page is left blank intentionally
Deze pagina is opzettelijk leeg gelaten



PC 50

IT

Descrizione:

Braccetto lungo 0,50 m con una portata di 5000Kg.

US

Description:

0.50 m long arm with a capacity of 5000 kg.

NL

Beschrijving:

0,50 m lange arm met een draagvermogen van 5000 kg.

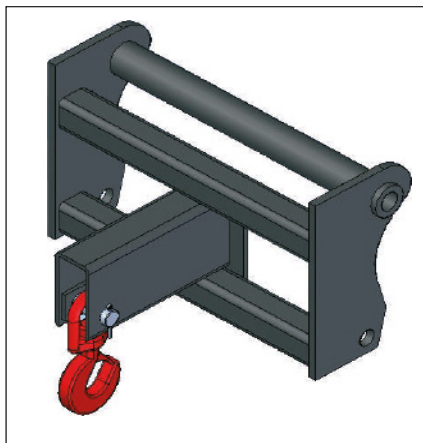



[kg] (lb)	[t] (t)	[mm] (in)									[kg] (lb)
5000 (11023)	5 (5)	A	B	C	D	E	F	G	H	I	120 (265)
		740 (29)	598 (23)	470 (18)	354 (14)	153 (6)	156 (6,1)	200 (7,8)	462 (18)	484 (19)	

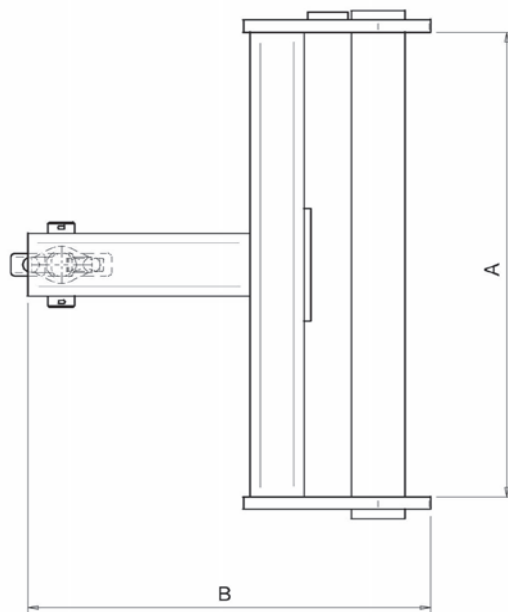
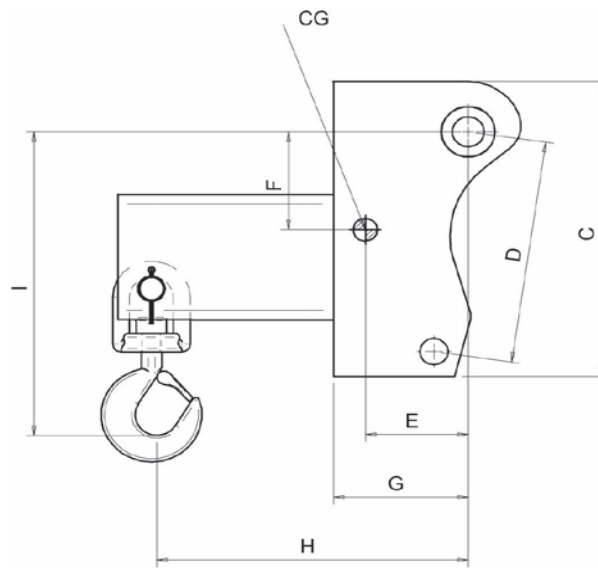



Questa pagina è intenzionalmente vuota
This page is left blank intentionally
Deze pagina is opzettelijk leeg gelaten



PC 60

IT

Descrizione:

Braccetto lungo 0,50 m con una portata di 6000Kg.

US

Description:

0.50 m long arm with a capacity of 6000 kg.

NL

Beschrijving:

0,50 m lange arm met een draagvermogen van 6000 kg.

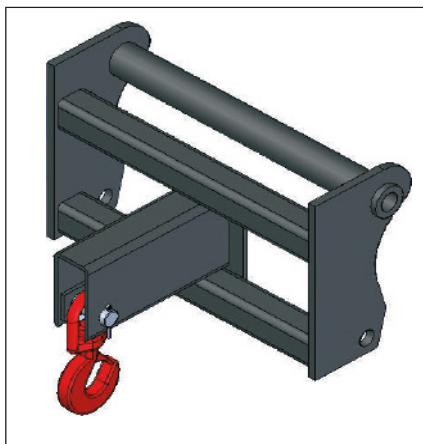



[kg] (lb)	[t] (t)	[mm] (in)									[kg] (lb)
6000 (13228)	6 (6)	A 740 (29)	B 598 (23)	C 470 (18)	D 354 (14)	E 153 (6)	F 156 (6,1)	G 200 (7,8)	H 462 (18)	I 484 (19)	120 (265)

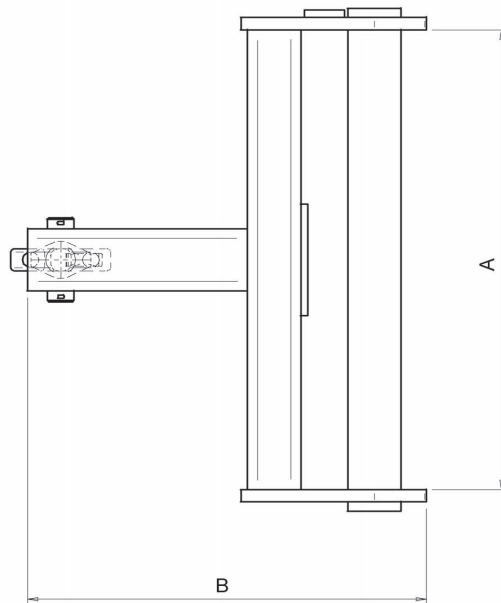
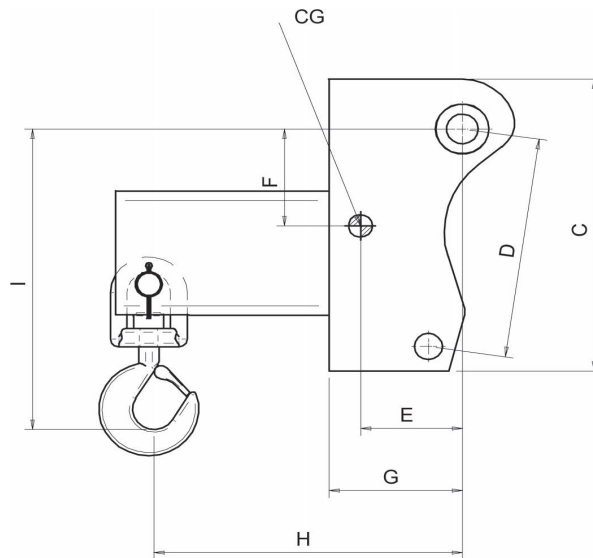



IT

US

NL

Questa pagina è intenzionalmente vuota
This page is left blank intentionally
Deze pagina is opzettelijk leeg gelaten



HBB 1500-2400

**Descrizione**

- Braccetto lungo 1,50 m.
- È in grado di movimentare indifferentemente i big bag a 1, 2 o 4 anse.
- Ha una capacità totale pari a 2400 kg, ovvero 4 posti da 600 kg ciascuno.

Description

- 1.50 m (4.9 ft) long arm.
- Handles indifferently big bags with 1, 2 or 4 ears (600 kg-1322 lb / loop).
- Total capacity of 2400 kg (5291 lb), 4 loading points with 600 kg (1322 lb) capacity each.

Beschrijving

- 1,5 m lange arm.
- Kan zonder problemen big bags met 1, 2 of 4 vouwen verplaatsen.
- Heeft een totaal draagvermogen van 2400 kg, d.w.z. 4 plaatsen van elk 600 kg.





[kg] (lb)	[mm] (in)																			[kg] (lb)
2400 (5291)	A	B	C	D	E	F	G	H	I	L	M	N	O	P	Q	R	S	T	U	186 (410)
	1570 (61.8)	710 (27.9)	650 (25.5)	388 (15.2)	190 (7.4)	1322 (52)	898 (35.3)	857 (33.7)	462 (18.1)	859 (33.8)	353 (13.8)	1648 (64.8)	750 (29.5)	15 (0.59)	700 (27.5)	1356 (53.3)	650 (25.5)	900 (35.4)	1000 (39.3)	

4 BAGS 600kg (1332 lb)

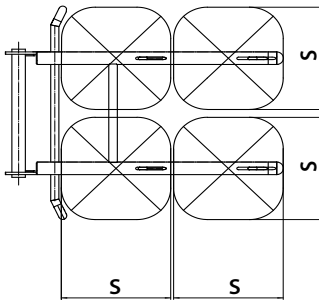

2 BAGS 1000kg (2204 lb)

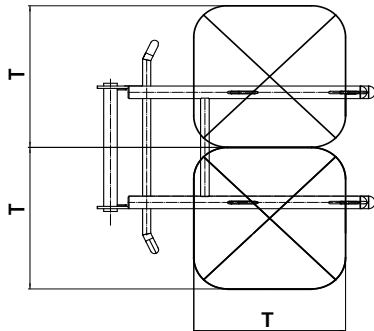

1 BAG 1500kg (3307 lb)

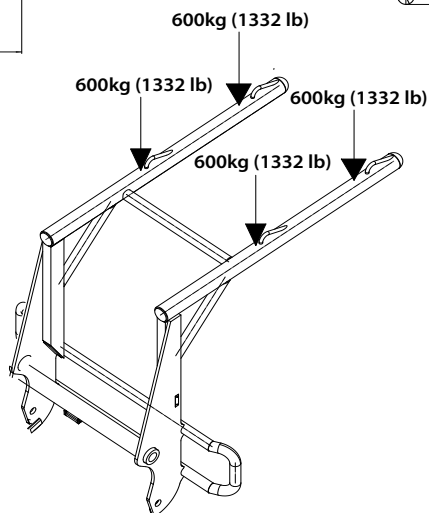
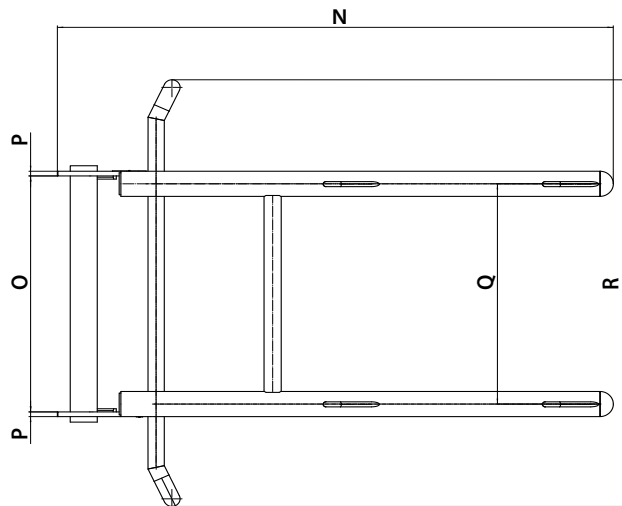
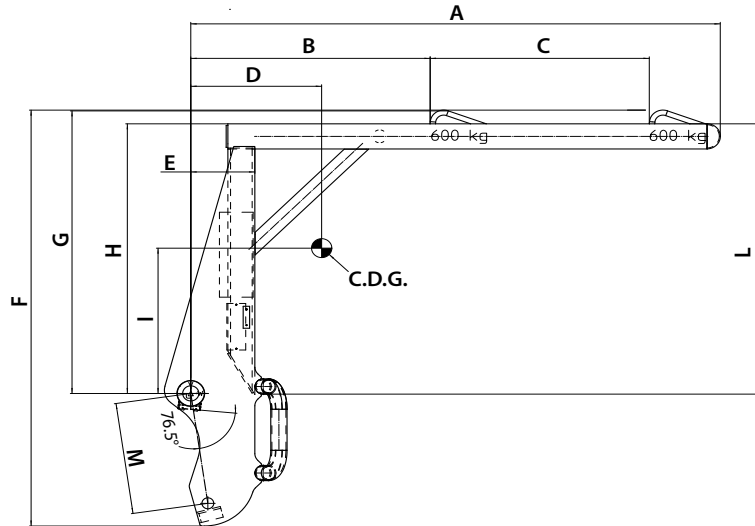
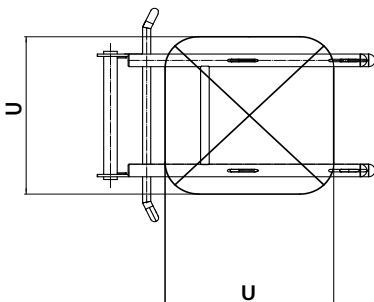



**3 - DIAGRAMMI DI CARICO
PER ATTREZZATURE
INTERCAMBIABILI
LOAD CHARTS FOR
INTERCHANGEABLE
EQUIPMENT
LAADDIAGRAMMEN
VOOR VERWISSELBARE
UITRUSTINGEN**



